

# **NESS** Access Control

## PRODUCT INSTALLATION GUIDE

### **CONTENTS**

1. PRODUCT CATALOG	
2. WIRING & INITIAL SETTING	1-14
3. INSTALLATION TIPS & CHECK POINT	15-19
4. SERIAL COMMUNICATION SETUP	20-26
5. LAN COMMUNICATION SETUP	27-35
6. DIAL-UP COMMUNICATION SETUP	36-42
7. DOOR LOCK INSTALLATION	43-55
8. POWER PACK CONNECTION	56
9. TROUBLE SHOOTING	9.1-9.19

Chapter **1**

**PRODUCT CATALOG**

# Chapter 2

## **WIRING & INITIAL SETTING**

### 2-3. Ness - IDTeck FGR006

#### 2-3-1. Star FGR006 Connection Diagram

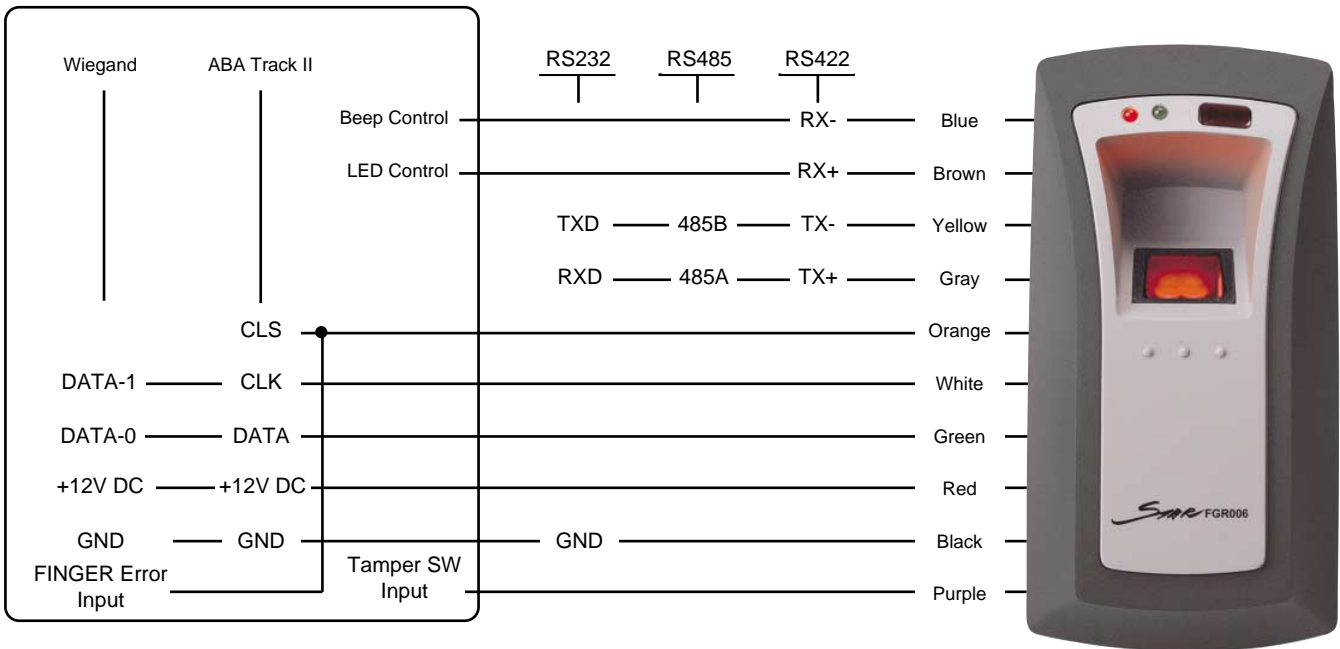

#### a. Caution

- a. The first card presented after initialization will be registered as master card.
- b. The unit shall be changed from reader mode to register mode with master card.

#### b. Intentional initialization (In case master card or ID is lost)

- a. Unit will be initialized when all dip switch move down.

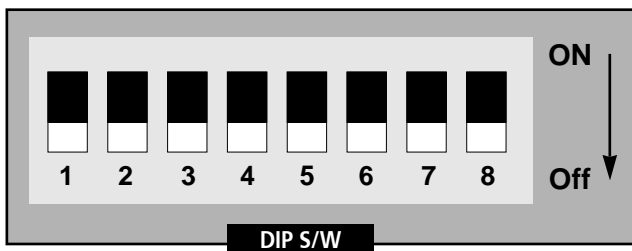

- b. Unit can be initialized from S/W.

#### c. User Registration/Deletion

- a. Change the unit to master mode with Master card.
- b. Present user card which will be registered
- c. If presented card has been registered already, user will be deleted instead of registration.
- d. If the card is not registered, the unit requires fingerprint data.
- e. Change the unit to reader mode with Master card.
  - Registration Mode : Red light (upper right)
  - Velification Mode : Power LED (upper left)

## 2-4 NESS - FGR006SRB

### 2-4-1 FGR006SRB System Diagram

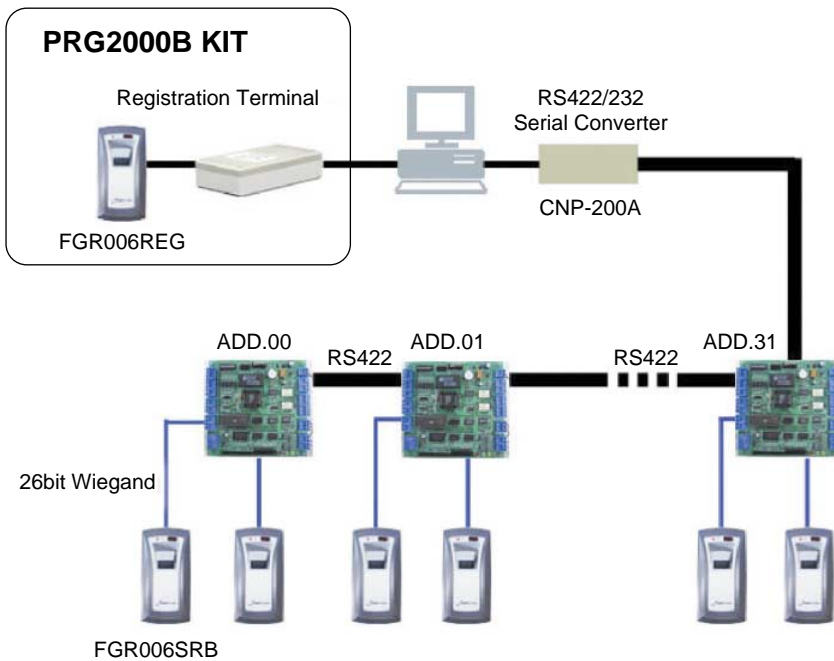
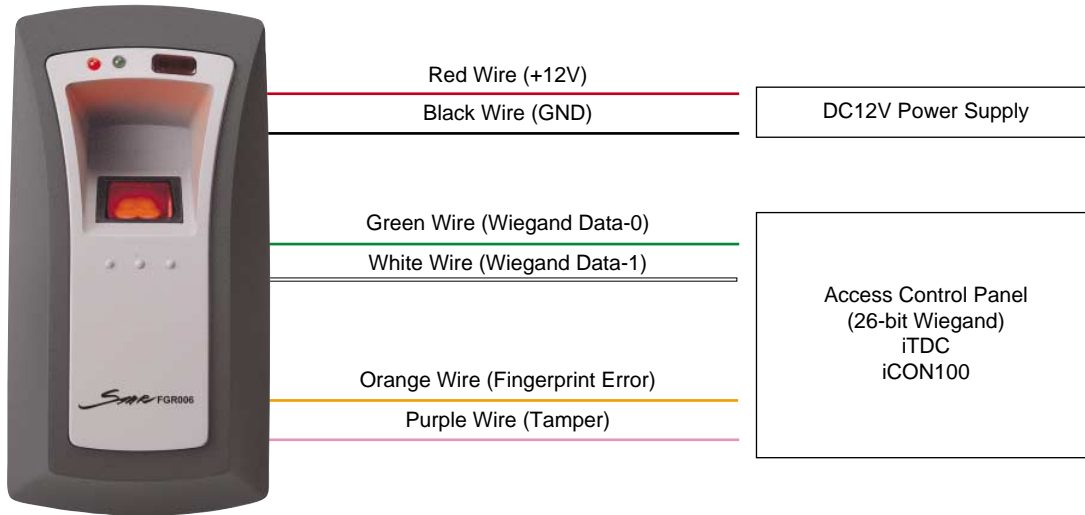

#### Consisting of PRG2000B Kit

- PRG2000B
- FGR006SRB REG (RS232)
- Application SW CD
- Power adapter : DC12V, 500mA
- Communication cable
- Software manual
- Table holder
- Smart card : 5ea

**a. System configuration for using FGR006SRB**

- a. Host PC (Spec : Pentium IV 1.7GHz, RAM 256M)
- b. PRG2000B Kit
- c. Controller (iCON100 or iTDC)
- d. Application Software
  - STARWATCH Dual Pro, STARWATCH iTDC Pro, STARWATCH Dual Pro 2, STARWATCH iTDC Pro 2

**b. Communication setting of PRG2000B Kit**

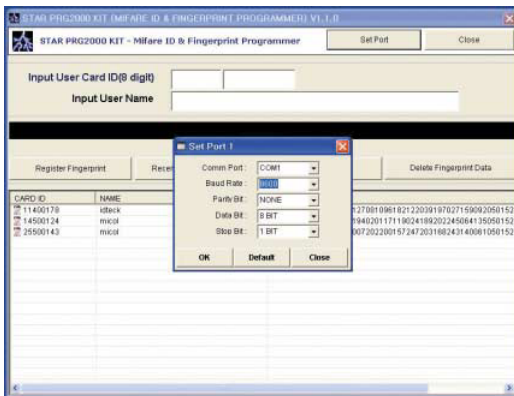

Click "Set port" as shown below and select the port which is connected to the encorder.

**c. Register Fingerprint**

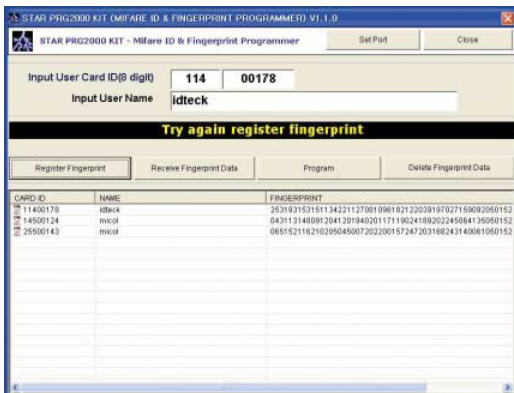

- Step 1. Register Fingerprint
  - Register fingerprint using FGR006SRB REG
- Step 2. Receiver Fingerprint Data
  - Send registered fingerprint data to PRG2000B
- Step 3. Program Smart card
  - Program Encrypted fingerprint data and I.D to Smart card



## 2-6. Ness 505R

### 2-6-1. Ness 505R Connection Diagram

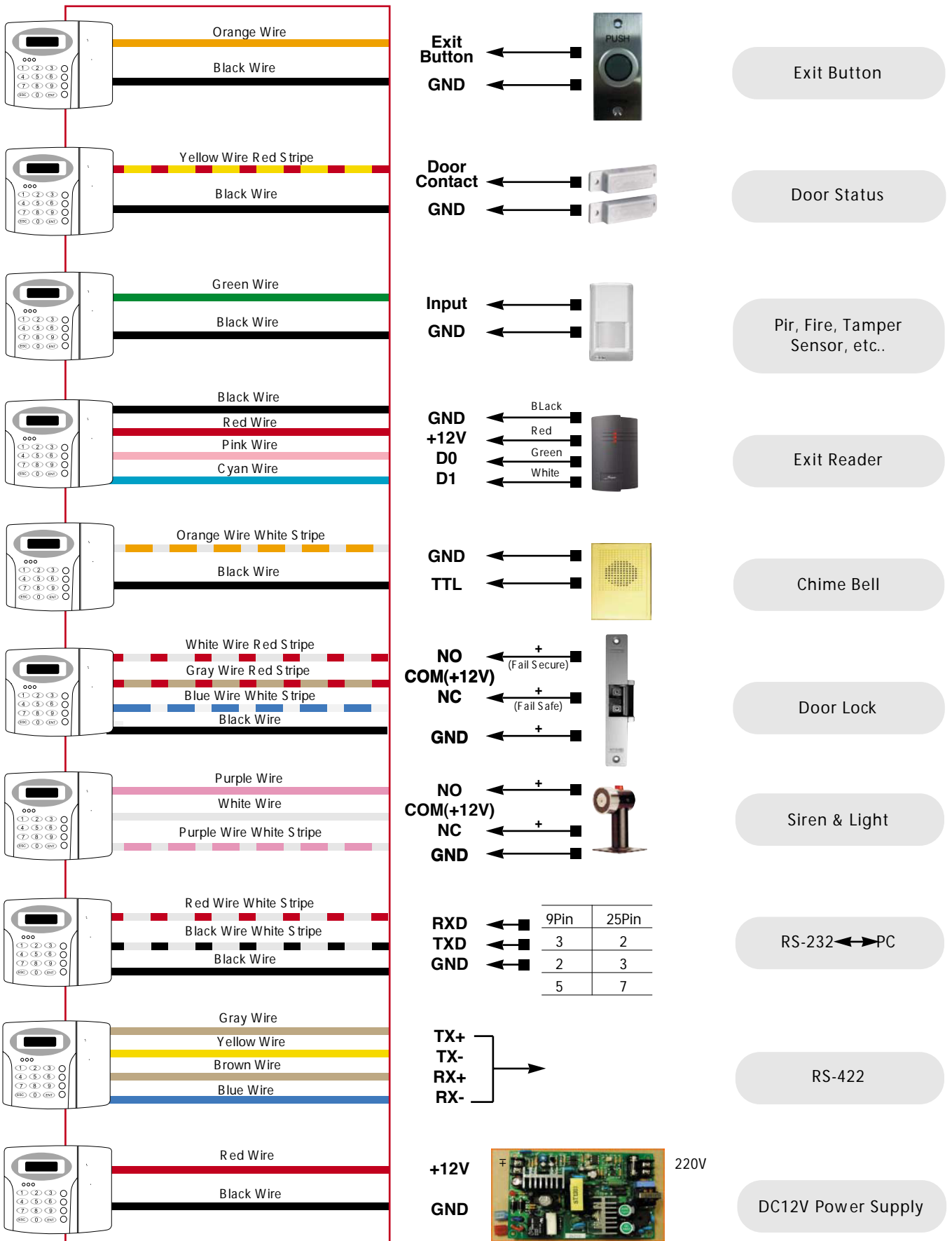

**2-6-2. Ness 505R initial setting**

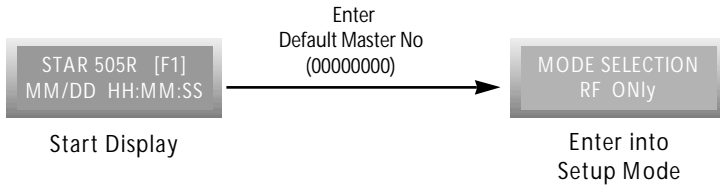

4 or 6 key : Left / Right move  
 2 or 8 key : Up / Down move  
 ENT : OK or Enter  
 ESC : Cancel or deactivate

**a. SET MODE SELECTION (Select mode with 4 or 6 Key)**

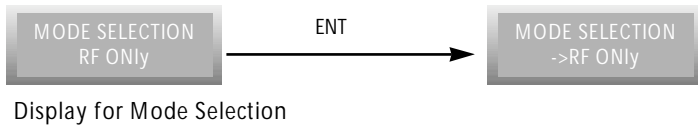

RF Only : Card  
 RF + P/W : Card + P/W

**b. SET ADDRESS (Select mode with 4 or 6 Key, Enter Address from Numeric Key)**

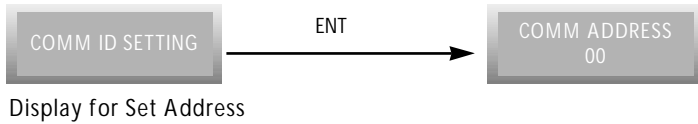

Press Ent under COMM ADDRESS status and enter address No(00 ~ 31)

**c. CARD REGISTRATION (Enter F3)**

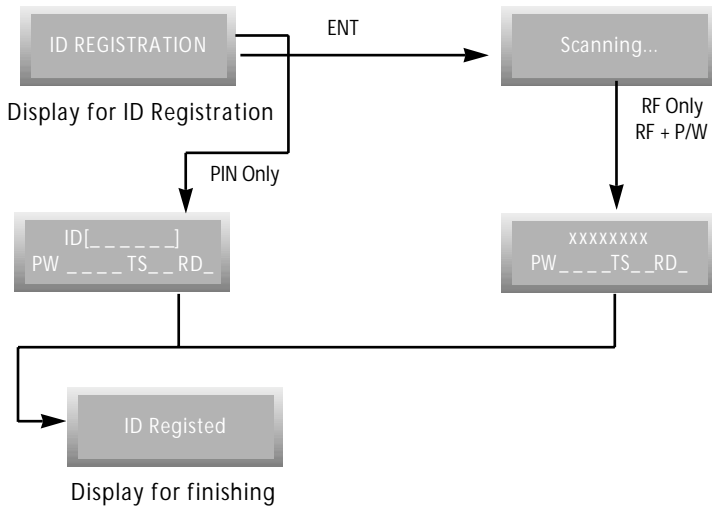

RF Only, RF + P/W MODE :  
 Register Card & P/W  
 PIN Only : Register PIN (4 ~ 6digit)

RF Only, RF + P/W: Card Reading  
 PIN Only: Register PIN (4 ~ 6digit)

TS: Set Time Schedule (DEFAULT:00)  
 ~ Set accessible time  
 RD: Set Reader mode(DEFAULT:3)  
 1 ~ Use only main device  
 2 ~ Use only exit reader  
 3 ~ Use both reader

**d. DELETE CARD (Enter F3, Search with 4 or 6)**

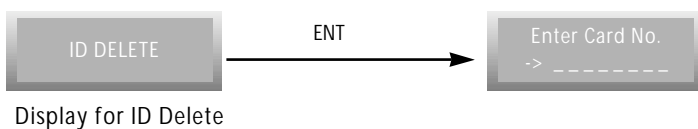

Present card or enter 4~6 or 8 digit No. which user wants to delete to delete ID.  
 PIN only mode : 4~6 digit No.  
 RF only, RF + P/W mode : 8 digit No.

**e. Hardware Initialization. (In case master card or ID is lost)**

1. Please check if the back-up battery DIP switches are on the backside of the device as the picture. If not, please set them on.

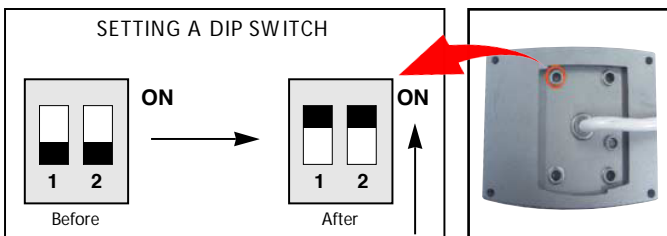

2. Connect three wires of pink, cyan and black color and turn the power on
3. A message of "system initialization" is to be shown in LCD
4. Press "1" to choose "Yes" then "system initialization completed" message is to show in the LCD
5. Disconnect those three wires and wire them as normal connection diagram as before

## 2-7. Ness - IDTeck FINGER007

### 2-7-1. Ness FINGER007 Connection Diagram

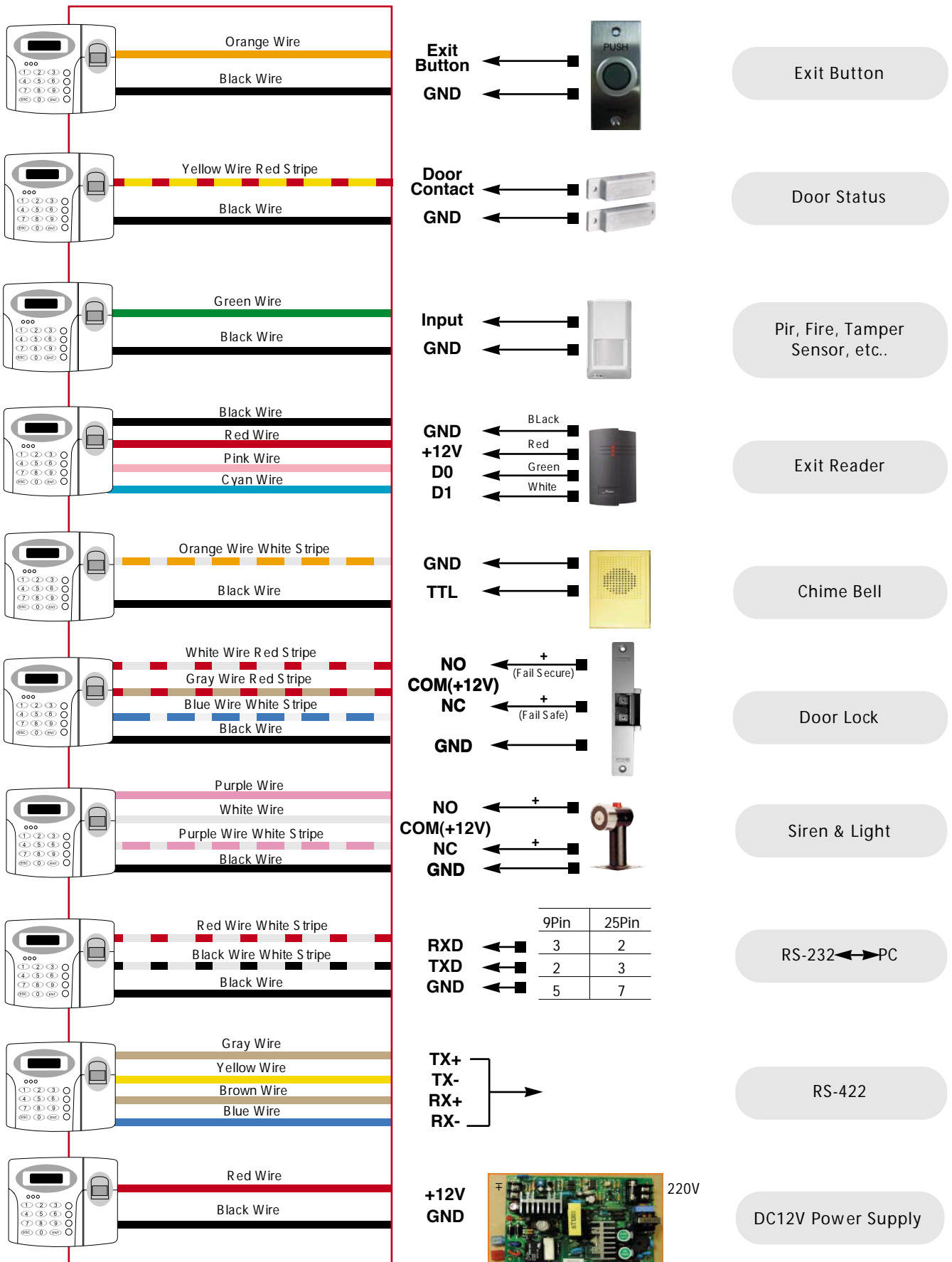

**2-7-2. Ness FINGER007 Initial Setting**

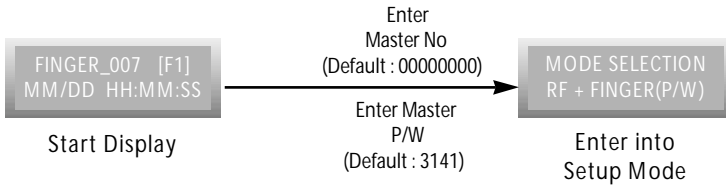

4 or 6 key : Left / Right MOVE  
 2 or 8 key : Up / Down MOVE  
 ENT : OK or Enter  
 ESC : Cancel or deactivate

**a. SET MODE SELECTION (Select mode with 4 or 6 Key)**

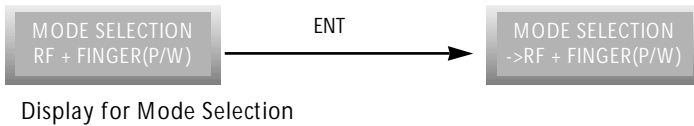

RF Only : Card  
 RF + FINGER(P/W) : Card + Finger(P/W)  
 RF + P/W + FINGER : Card + P/W + Finger

**b. SET ADDRESS (Select mode with 4 or 6 Key, Enter Address from Numeric Key)**

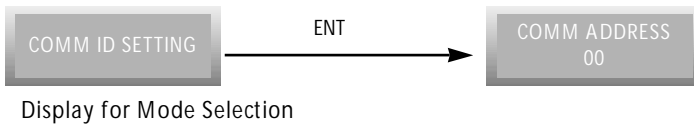

Press Ent under COMM ADDRESS status and enter address No(00 ~ 31)

**c. CARD & FINGER REGISTRATION (F3 KEY)**

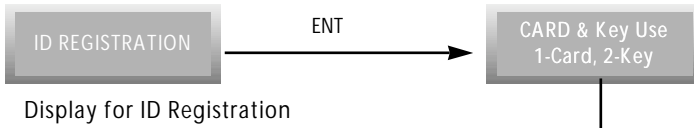

1 - Card : Register card & fingerprint  
 2 - Key : Register PIN(4~8 digit) & fingerprint

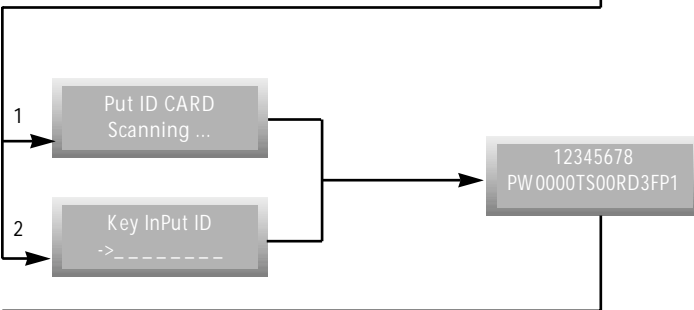

Ent 1: Present Card, Ent 2: Enter PIN(4~8 digit)  
 PW: Enter P/W  
 ~ Will be used under P/W mode  
 TS: Set Time Schedule  
 ~ Set accessible time  
 RD: Set Reader mode  
 1 ~ Use only main device  
 2 ~ Use only exit reader  
 3 ~ Use both reader  
 FP: Use/Not use Fingerprint  
 (1: Use, 0: Not use)

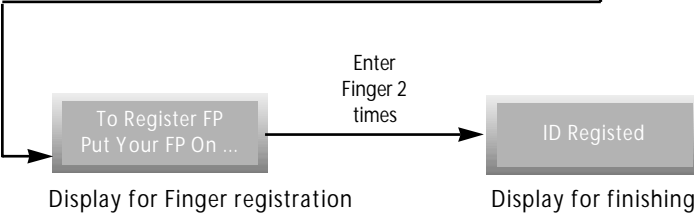

Caution : Present finger on scan window closely and press softly to make sure that the fingerprint is positioned correctly

**d. DELETE CARD & FINGERPRINT (Enter F3, Search with 4 or 6)**

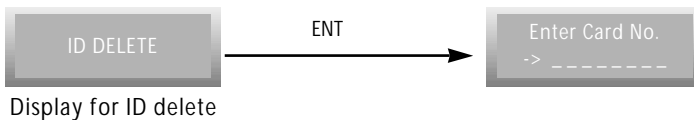

Present card or enter 4~8 digit No. intended to delete (In case of 4 digit No. Enter '0000' before the No to make it 8 digit No.)

**e. Hardware Initialization. (In case master card or ID is lost)**

1. Please check if the back-up battery dip switches are on the backside of the device as the picture. If not, please set them on.

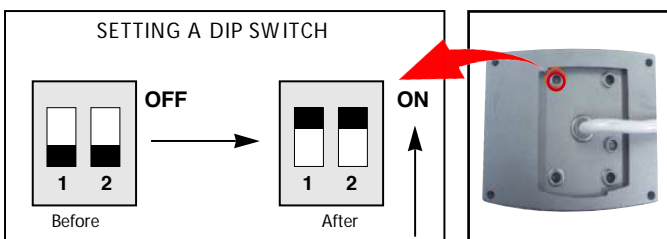

2. Connect three wires of pink, cyan and black color and turn the power on
3. A message of "system initialization" is to be shown in LCD
4. Press "1" to choose "Yes" and enter default master P/W (3141) then "system initialization completed" message is to show in the LCD
5. Disconnect those three wires and wire them as normal connection diagram as before

## 2-8. NESS ICON100

### 2-8-1. Ness ICON100 Connection Diagram

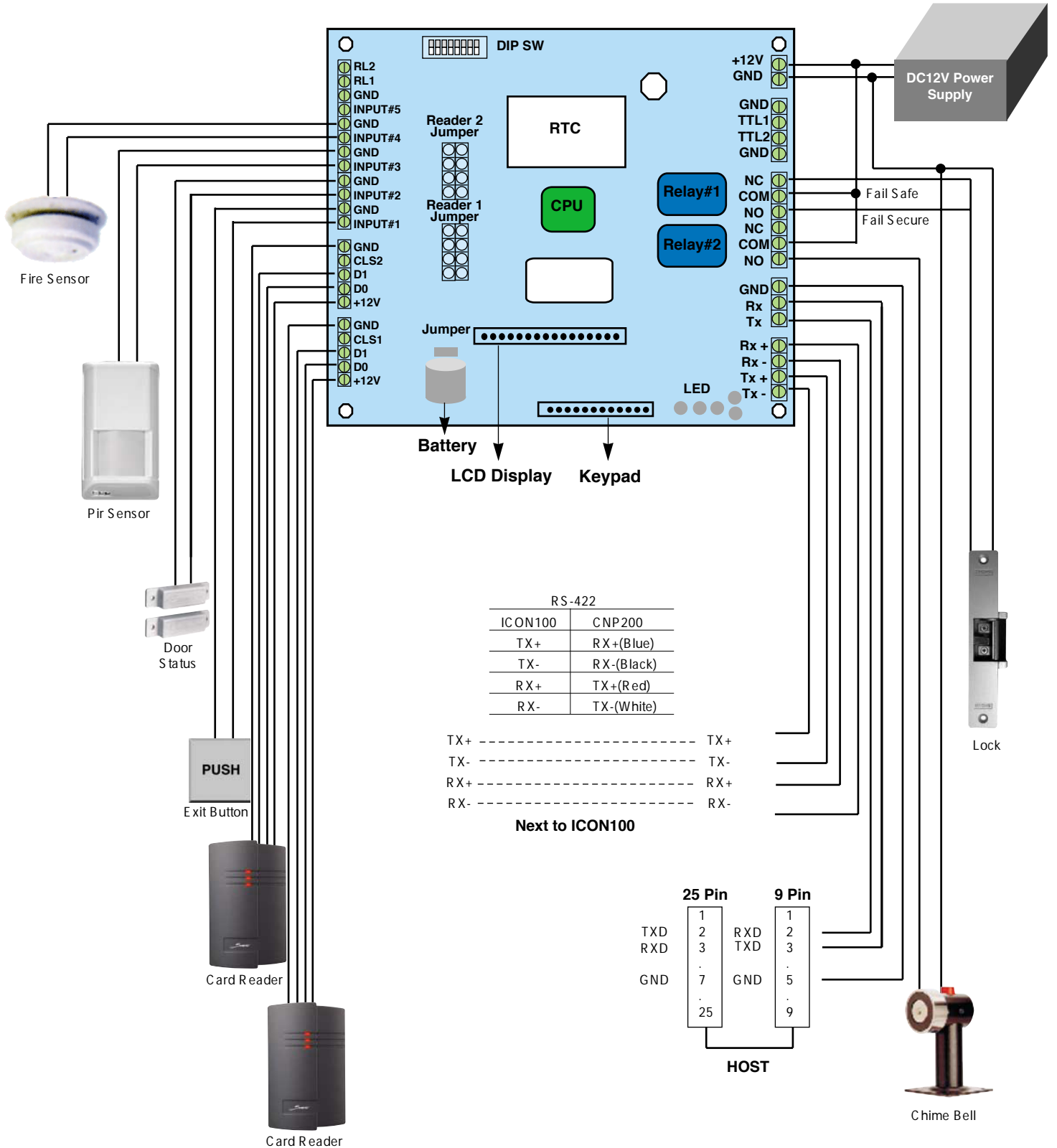

2-8-2. Ness ICON Initial Setting

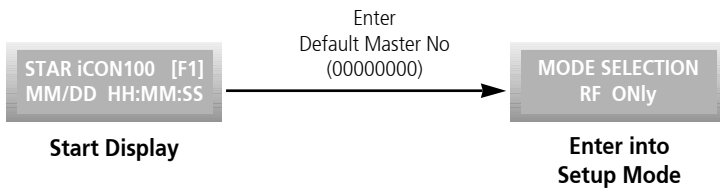

4 or 6 key : Left / Right MOVE  
 2 or 8 key : Up / Down MOVE  
 ENT : OK or Enter  
 ESC : Cancel or deactivate

a. SET MODE SELECTION (Select mode with 4 or 6 Key)

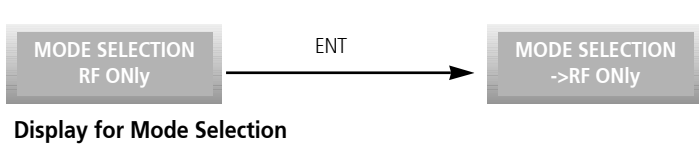

RF Only : Card  
 RF + P/W : Card + P/W

b. SET ADDRESS (Select mode with 4 or 6 Key)

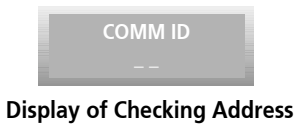

- Address for ICON100 can be set from DIP S/W and menu only gives number of address.
- Refer DIP S/W setting table

c. CARD REGISTRATION (Enter F3)

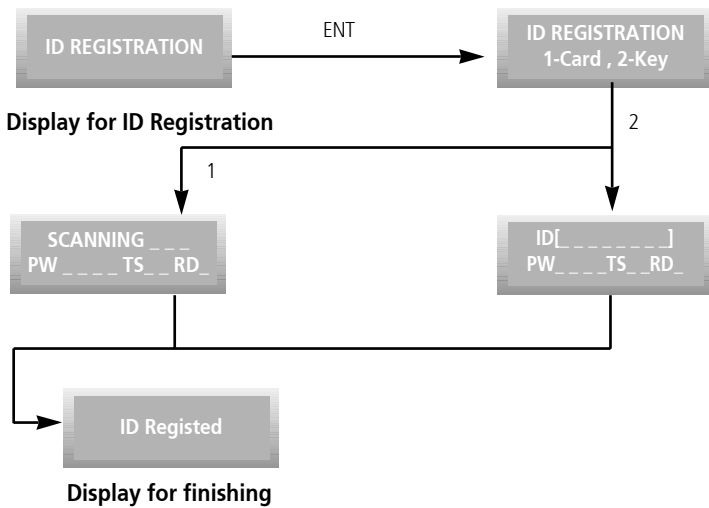

1. Card : Card Reading  
 2. Key : Enter PIN (8digit)

ID : Enter 8 digits ID number  
 PW: Enter P/W which will be used under P/W mode (4 digit)  
 TS: Set Time Schedule (DEFAULT:00)  
 ~ Set accessible time  
 RD: Set Reader mode(DEFAULT:3)  
 1 ~ Use only Reader 1 (IN)  
 2 ~ Use only Reader 2 (OUT)  
 3 ~ Use both readers

d. DELETE CARD (Enter F3, Search with 4 or 6)

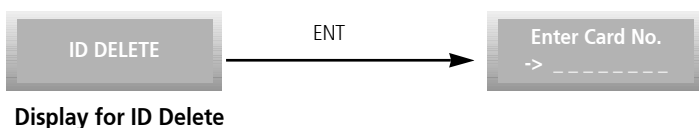

Enter No. which user wants to delete to delete ID.

### 2-8-3. Ness ICON100 setting manual

#### a. BATTERY JUMPER

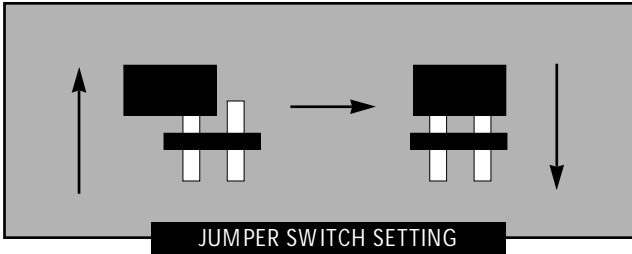

iCON100 has a jumper for backup battery connection, that is left open circuit to prevent current consumption of backup battery.

It needs to connect the jumper for backup battery operation during power failure.

#### b. ADDRESS SETTING

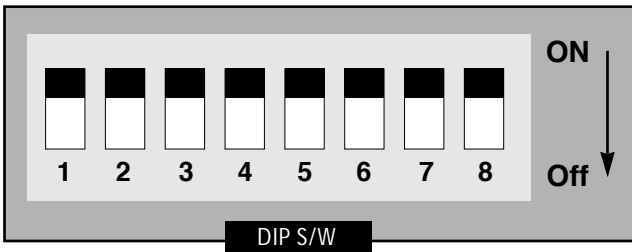

There is 8 bit DIP SW for address setting and it turns to 8 bit binary code. Each bit has fixed address value, the address is calculated the sum value of each bit set to "1" position. The same address is set both hardware and software

#### c. ADDRESSING UNIT (SELECT ADDRESS FROM DIP S/W)

	0	1	2	3	4	5	6	7	8	9	10	11	12	13	14	15	16	17	18	19	20	21	22	23	24	25	26	27	28	29	30	31				
1	ON	OFF	ON	OFF	ON	OFF	ON	OFF	ON	OFF	ON	OFF	ON	OFF	ON	OFF	ON	OFF	ON	OFF	ON	OFF	ON	OFF	ON	OFF	ON	OFF	ON	OFF	ON	OFF	ON	OFF		
2	ON	ON	OFF	OFF	ON	ON	OFF	OFF	ON	ON	OFF	OFF	ON	ON	OFF	OFF	ON	ON	OFF	OFF	ON	ON	OFF	OFF	ON	ON	OFF	OFF	ON	ON	OFF	OFF	ON	ON	OFF	OFF
3	ON	ON	ON	ON	OFF	OFF	OFF	OFF	ON	ON	ON	ON	OFF	OFF	OFF	OFF	ON	ON	ON	ON	OFF	OFF	OFF	OFF	ON	ON	ON	ON	OFF	OFF	OFF	OFF	OFF	OFF	OFF	
4	ON	ON	ON	ON	ON	ON	ON	ON	OFF	OFF	OFF	OFF	OFF	OFF	OFF	OFF	ON	ON	ON	ON	ON	ON	ON	ON	OFF	OFF	OFF	OFF	OFF	OFF	OFF	OFF	OFF	OFF	OFF	
5	ON	ON	ON	ON	ON	ON	ON	ON	ON	ON	ON	ON	ON	ON	ON	OFF	OFF	OFF	OFF	OFF	OFF	OFF	OFF	OFF	OFF	OFF	OFF	OFF	OFF	OFF	OFF	OFF	OFF	OFF	OFF	OFF
6	ON	ON	ON	ON	ON	ON	ON	ON	ON	ON	ON	ON	ON	ON	ON	ON	ON	ON	ON	ON	ON	ON	ON	ON	ON	ON	ON	ON	ON	ON	ON	ON	ON	ON	ON	ON
7	ON	ON	ON	ON	ON	ON	ON	ON	ON	ON	ON	ON	ON	ON	ON	ON	ON	ON	ON	ON	ON	ON	ON	ON	ON	ON	ON	ON	ON	ON	ON	ON	ON	ON	ON	ON
8	ON	ON	ON	ON	ON	ON	ON	ON	ON	ON	ON	ON	ON	ON	ON	ON	ON	ON	ON	ON	ON	ON	ON	ON	ON	ON	ON	ON	ON	ON	ON	ON	ON	ON	ON	ON

Table 1 : The relation between Setting and DIP switch

EX) Address 15 : Since  $15=1+2+4+8$  , off 1,2,3,4 switch to set 15.

#### d. SYSTEM INITIALIZATION (FROM DIP SWITCH)

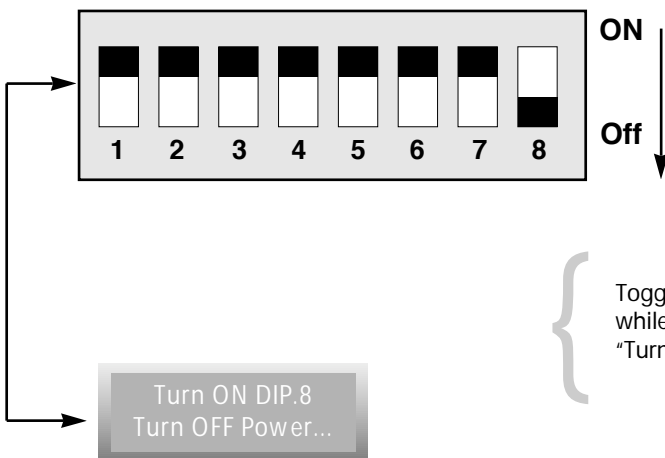

Toggle the switch 8 to 'off' and toggle it back to 'on' while the power is on. If the LCD displays the message of "Turn on DIP 8 Turn off power", Turn off power.

## 2-9. NESS iTDC - 2/4 Door Controller

### 2-9-1. iTDC Connection Diagram

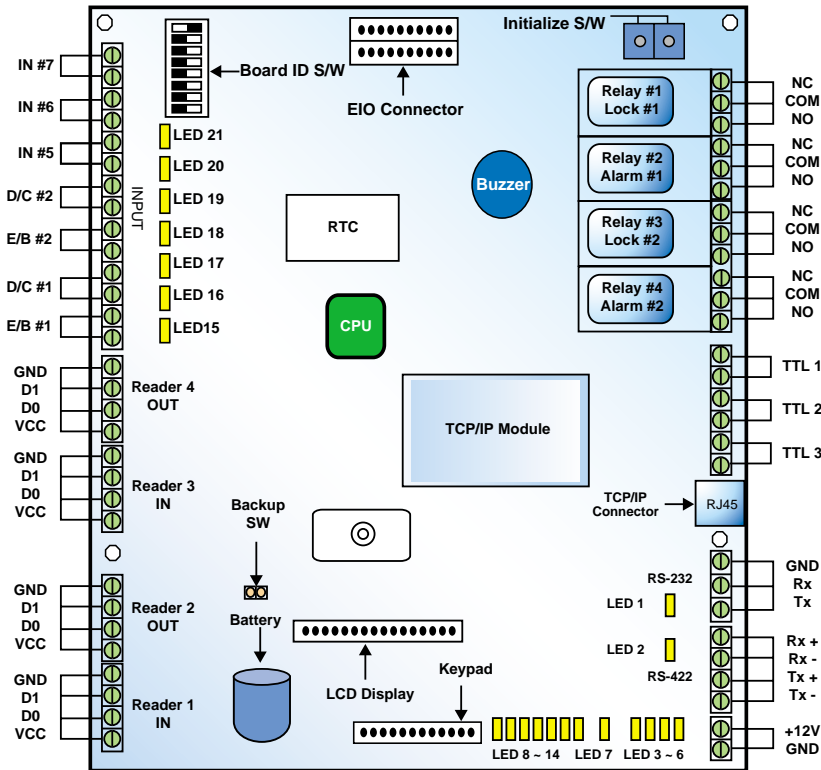

### 2-9-2. EIO88 Connection Diagram

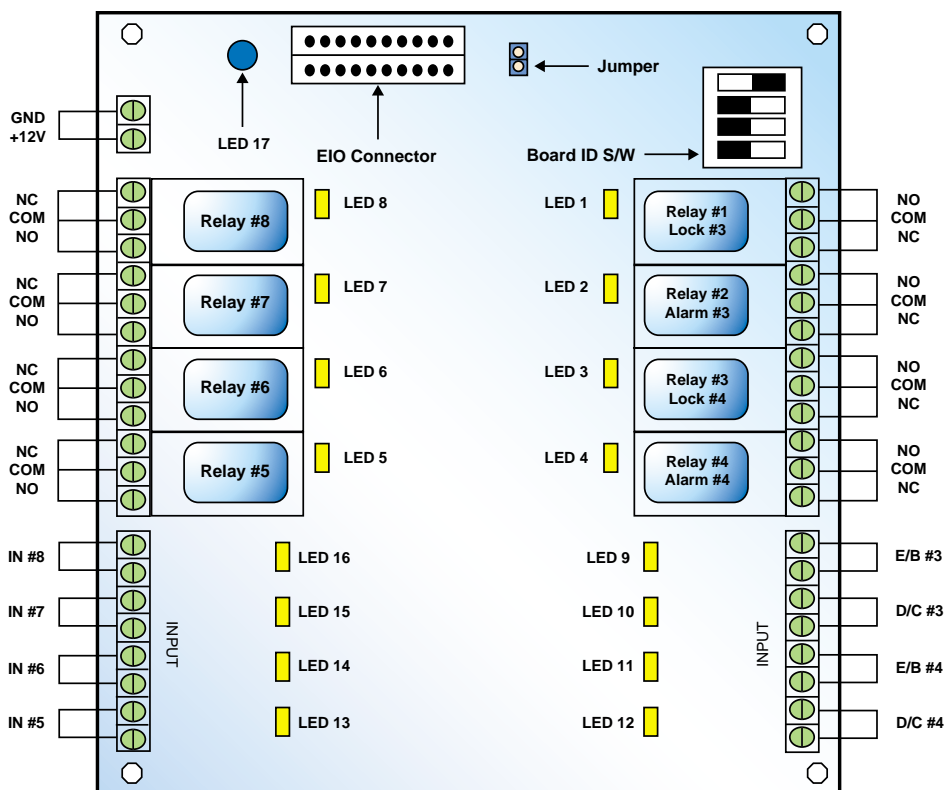

### 2-9-3. Ness - iTDC initial setting

Before Setting, make sure all wires are correctly connected refering its connection diagram.

#### a. Battery Jumper

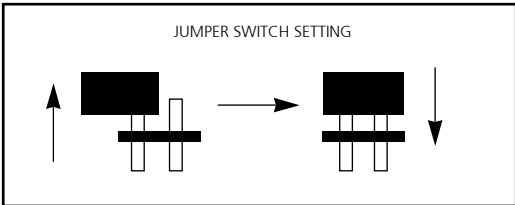

iTDC has a jumper for backup battery connection, that is left open circuit to prevent current consumption of backup battery.

It needs to connect the jumper for backup battery operation during power failure.

#### b. Initialization Switch

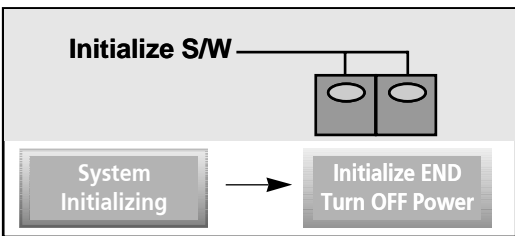

System initialization is recommended to clear mal data possibly produced during its installation. Turn its power on and press the two initialization switches simultaneously.

The LCD will first display "System Initializing...". After the all Initialization process is completed the LCD will display "Initialize END Turn OFF Power...". Turn the power off then turn on again to operate the system.

#### c. Address Setting

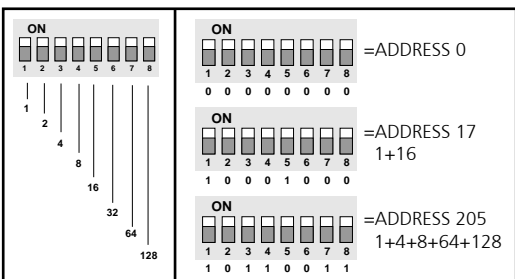

There is 8 bit DIP SW for address setting and it turns to 8 bit binary code. Each bit has fixed address value, the address is calculated the sum value of each bit set to "1" position. The same address is set both hardware and software

#### d. Door Number Setting

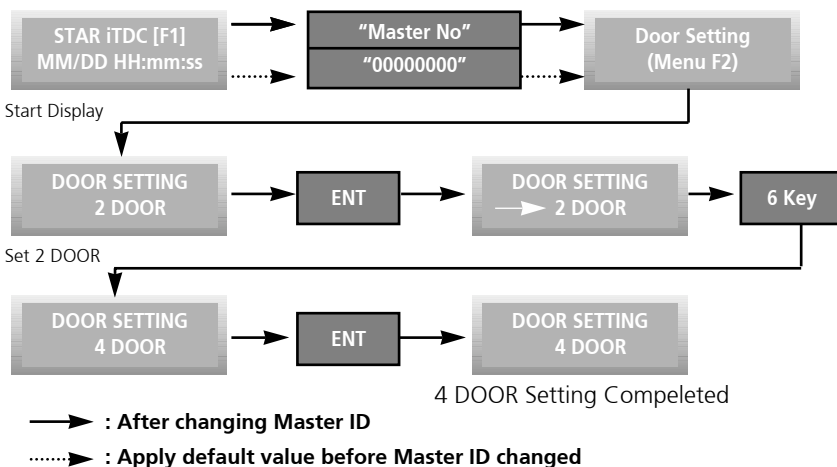

2DOOR : Control both IN/OUT for 2 doors

	IN	OUT
Door 1	Reader #1	Reader #2
Door 2	Reader #3	Reader #4

4 DOOR : Each Reader 1~4 controls single door

	IN	OUT
Door 1	Reader #1	Exit Button
Door 2	Reader #2	Exit Button
Door 3	Reader #3	Exit Button
Door 4	Reader #4	Exit Button

2-9-4. User ID registration

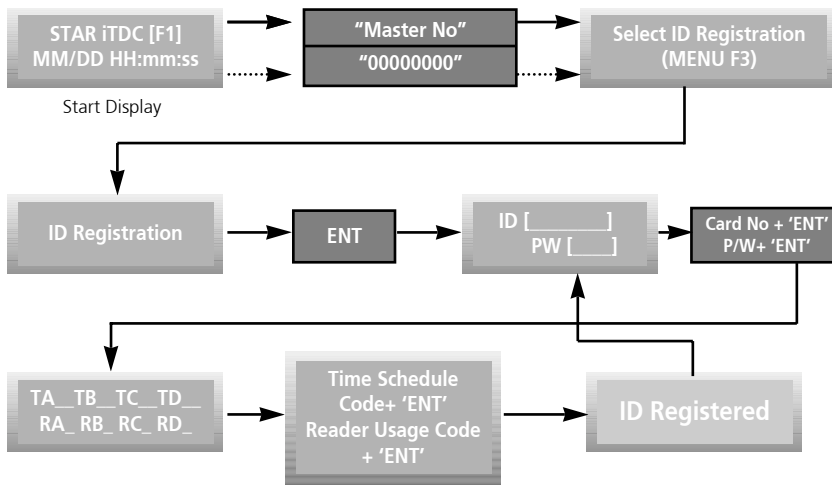

1. ID[ ] : ID number consists of 3-digits Facility code from 000 to 255 and 5-digits ID number from 00000 to 65535 so that the 8-digits ID number can not exceed 25565535. If you don't know the ID number of the proximity cards then select [SETUP MENU F4] -> [READER TEST] then present the card to the reader to display the ID number. Enter 8-digits ID number then press <ENT> key in the ID[ ] field.

2. PW[ ] : PW is the password which can be used to access the doors where you install a Proximity and Keypad Reader and setup the RF+Password operating mode. But regardless of the operating mode, it is necessary to enter a default password (0000) in the PW[ ] field when you register ID.

3. TA\_TB\_TC\_TD\_\_ : TA, TB, TC and TD are Time Schedule code (00-15) for the Readers, TA is the Time Schedule for the Reader #1, TB is for Reader #2, TC is for Reader #3 and TD is for Reader #4. When you present the card to Reader #1 then the cardholder is only allowed the access of the door during the Time Schedule code entered to TA\_\_ and the other Readers are the same manner. **If you want to access the door anytime for the cardholder then enter default Time Schedule code '00' for the value.**

4. RA\_\_RB\_\_RC\_\_RD\_\_ : RA, RB, RC and RD are Reader Usage codes for the cardholder. If you put '1' for RA then Reader #1 is accessible and if you put '0' for RA then the cardholder can not access through the Reader #1 and iTDC generates an error message "Access Door Error" and displays on the LCD. To get access through all 4 Readers, you have to input '1' value for RA, RB, RC and RD.

2-9-5. User ID Deletion

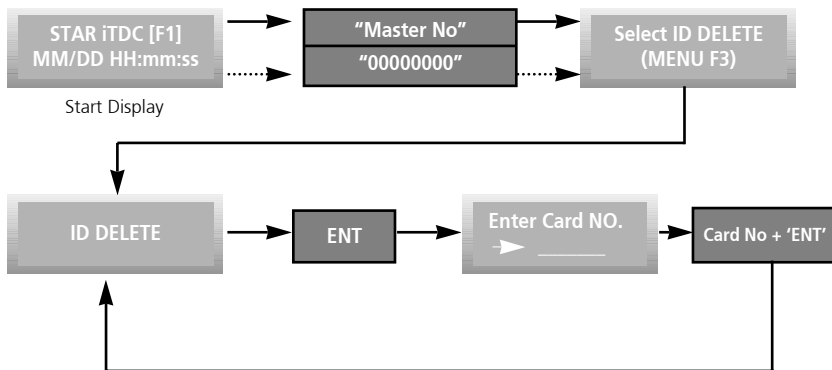

1. User can be deleted from software or iTDC directly by entering card No. If the card No is not sure, card number will be shown when you present card to reader under reader test mode which can be found F4 menu.

2. Enter 8 digit User ID that you want to delete and press ENT. The range of the first 8 digit is 000~255 and the last 5 digit 00000~65535 from 8 digit card No.

3. If the User ID you entered is found, the User ID will be deleted and display "ID Deleted" and if the User ID is not found then only display "ID Unregistered". You may repeat ID DELETE many times and press <ESC> key to exit the menu.

## 2-10. Ness - IDTeck RF500 and IDA500

### 2-10-1. Special Features of RF500

- 1) Site-code; IDA500 tag has a site-code which is programmed with the ID number of tags and RF500 has also the same site-code so that the reader only can active if the tag has same site-code. This feature is to distinguish the tags are using other countries or other customer's site. Once the reader power is applied, the site-code of the reader is set to default site-code (000) and the reader restores a site-code from the first read (detected) IDA500 tag so after that RF500 reader only detects the tags have the same site-code. IDTECK assigns site-code for the customers.
- 2) RF500 reader has 8 channels of reader addresses and factory setting of reader address is set to '0' address. You may change the reader address by setting the two external wires to ground level. Please refer to the RF500 Users Manual.
- 3) RF500 reader has bi-directional characteristics but it can be active as one direction if the IDA500 tag has a sleep timer itself.

### 2-10-2. Special Features of IDA500

- 1) IDA500 tag only respond when the tag received reader signal (reader address) from the RF500 reader and the tag wakes up every 250ms. (1/4 sec.)
- 2) IDA500 tag is programmed with following codes.
  - Site-code: Site-code is a kind of customer code and IDTECK assigns this.
  - Sleep-time: IDA500 has a sleep-time can be programmed up to 256 min.
  - If IDA500 has sleep-time '0' then the tag is active continuously.
    - If you set sleep-time to 30 sec. then the tag is only active when the tag is away for 30 sec. from the read range of RF500 readers.
  - Toggle-mode: If you set Toggle-mode ON, IDA500 toggles active and de-active.
    - In this case, IDA500 only be detected 1,3,5,7.... Odd numbers of reading time and no active for 2,4,6,8... even numbers of reading time. Factory default setting is Toggle-mode OFF.
  - Facility-code: This Facility-code is including the tag ID (first 3 digit, 000~255)
  - ID-number: This ID-number is including the tag ID (last 5 digit, 00001~65535)

### 2-10-3. Application of the Ness RF500 and IDA500 for Parking controls

**In case, In-Gate controls by IDA500 tag and Out-Gate only controls by loop sensors**

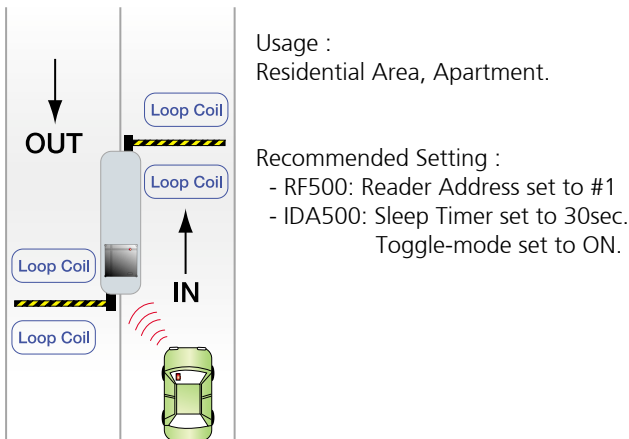

**In case, In-Gate controls by IDA500 tag and Out-Gate also controls by IDA500 tag**

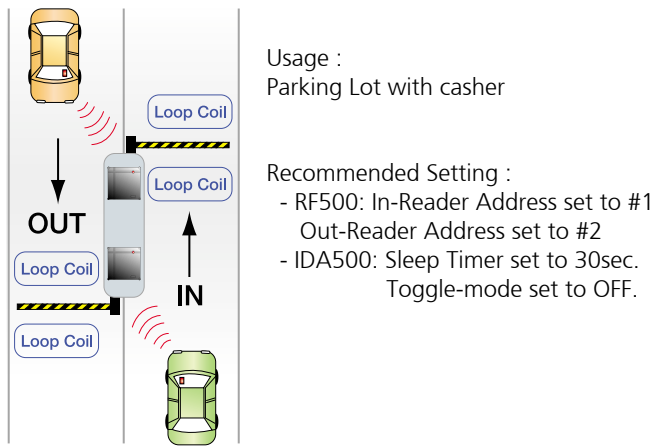

**In case, multiple In-Gates control by IDA500 tag and multiple Out-Gates also control by IDA500 tag**

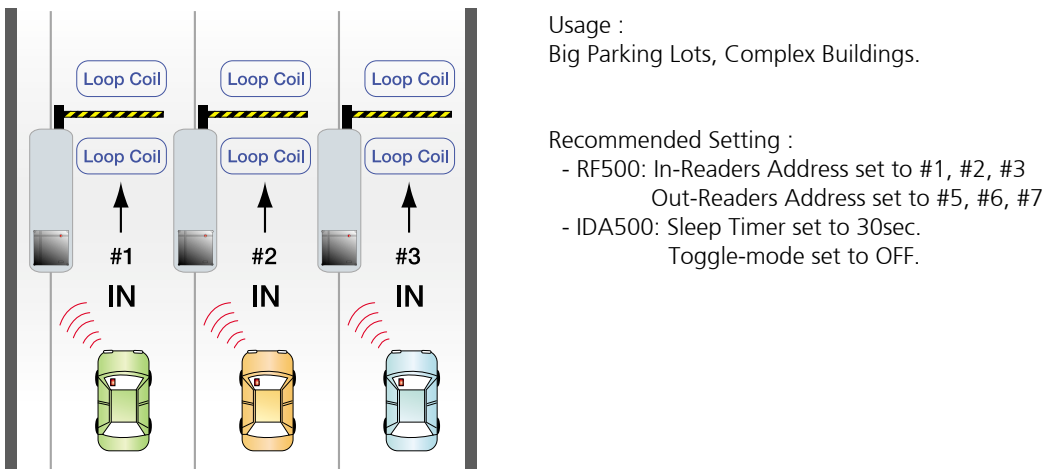

Chapter **3**

**INSTALLATION TIPS &  
CHECK POINT**

### 3-1. Check points before installation

#### 3-1-1 Selection of cable

System installation cabling will be configured as follow.

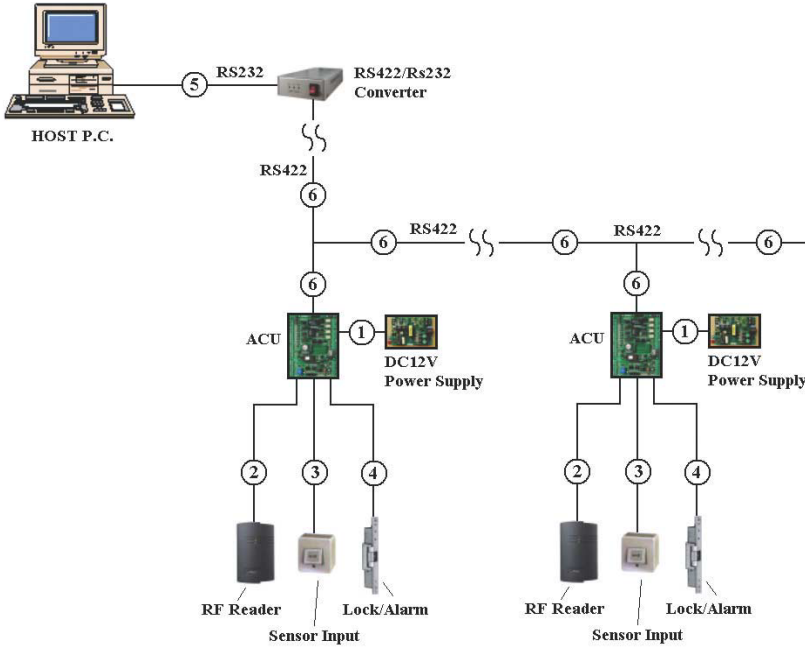

Fig.1 : System Installation Layout

#### 3-1-2. Tips for Placing Devices

Reference	Description	Cable Specification	Maximum Distance
•	ACU Power (DC12V) DC Power -> ACU	Ness CAB240, 18 AWG 2 conductor, unshielded	30m
• *	Reader (Power and Data) Reader -> ACU	Belden #9512, 22 AWG or Ness # 101-170 Shielded Belden #9514, 22 AWG or Ness # 101-170 Shielded	150m
•	Door Contact Exit Button Sensor Input Input -> ACU	Belden #9512, 22 AWG or Ness CAB 110 Belden #9514, 22 AWG or Ness CAB 110	300m
•	Door Lock, Alarm Device Lock (Alarm) -> ACU	Belden #9409, 18AWG or Ness CAB 110	300m
•	RS232 Cable Converter -> Host P.C.	Belden #9829, 24 AWG or Ness #101-170 Shielded	15m
•	RS485 Cable ACU -> ACU ACU -> Converter	Belden #9829, 24 AWG 2-twisted pair, shielded	1,200m
	RS422 Cable ACU -> ACU ACU -> Converter	Belden #9830, 24 AWG or Ness # 101-170 Shielded	

\* Need thicker wire if you connect the reader with high current consumption.

### 3-2. Check Points During Installation

#### 3-2-1. Terminating Resistance

Termination resistors are used to match impedance of the network to the impedance of the transmission line being used. When impedance is mismatched, the transmitted signal is not completely absorbed by the receiver and a portion of signal is reflected back into the transmission line.

The decision whether or not to use termination resistors should be based on the cable length and data rate used by the communication system.

For example, if you use 9,600 baud rate and 1,200m length of cable, the propagation velocity of cable is 0.66 x speed of light (This value is specified by the cable manufacturer), if we assume the reflections will damp out in three round trip up and down the cable length, the transmitted signal will stabilize 18.6us after the leading edge of a bit. Since the data bit is captured in the middle of the bit which is approximately 52us after the leading edge of a bit. The reflection stabilizing time 18.6us is much before the center of the bit therefore the termination resistors are not required.

However, if you install the cable to maximum length, the impedance of cable and network is mismatched and the transmitted signal is overlapped by the reflected signal. In this case, it is recommended to add termination resistors to the end of the receiver lines. A 120Ω resistor can be used for termination resistor in parallel between the receiver lines "A" and "B" for 2 wires RS485 system or "RX+" and "RX-" for 4 wires RS422 system. A termination resistor of less than 90Ω should not be used and no more than 2 terminations should be used in one networking system.

#### 3-2-2. How to connect termination resistors

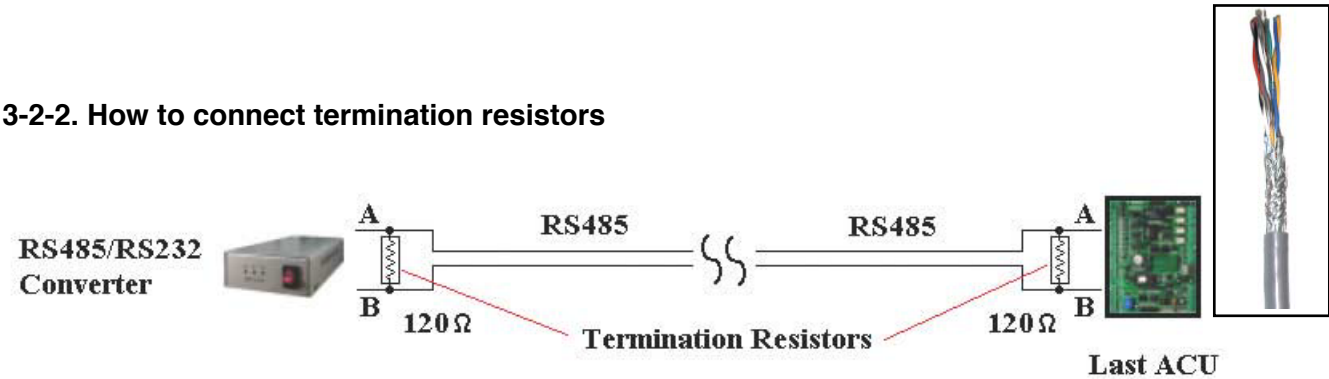

Fig.2 : Termination resistors for 2 wires RS485 communication system

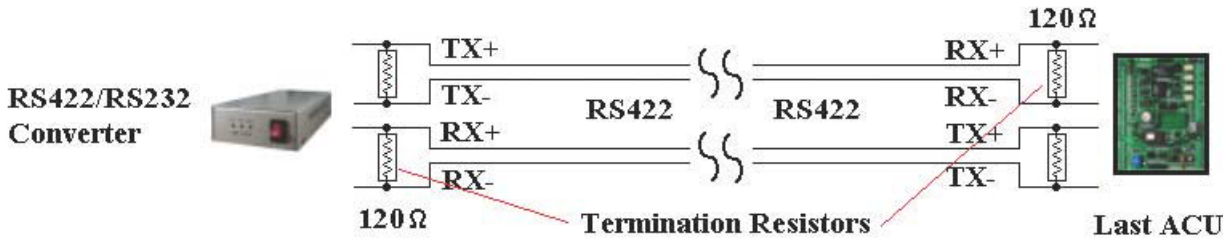

Fig.3 : Termination resistors for 4 wires RS422 communication system

### 3-2-3. Grounding system for communication cable

We recommend to using proper grounding system on the communication cable. The best method for grounding system is to put the shield wire of communication cable to the 1st class earth grounding; however it is not so easy to bring the earth ground to the communication cable and also the installation cost is raised.

There will be three grounding point where you can find during installation;

- 1) Earth Ground
- 2) Chassis Ground
- 3) Power Ground

The most important point for grounding system is not to connect both ends of shield wires to grounding system; in this case there will be a current flow through the shield wire when the voltage level of both ends of shield wire is not equal and this current flow will create noise and interfere to communications. For the good grounding, we recommend to connecting ONLY one end of shield wire of communication cable to grounding system; If you find earth ground nearby, then connect one end of shield wire to earth ground; If you do not have earth ground nearby, then find chassis ground and connect one end of shield wire to chassis ground; If you do not find earth ground or chassis ground, then connect one end of shield wire to power ground. (GND of ACU)

Note that if the chassis ground is not properly connected to the earth and floated from the ground level, then grounding to the chassis ground will give the worst communication; in this case we recommend to using power ground instead of chassis ground

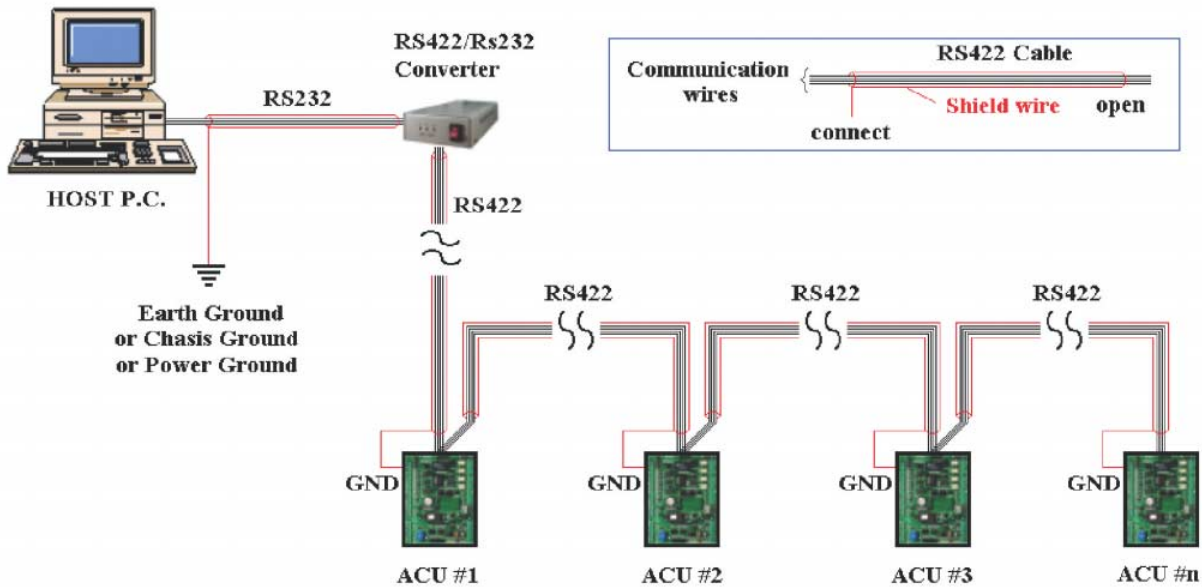

Fig.4 : Grounding System

**3-2-4. Reverse Diode connection**

If you connect an inductor (Door Locks or Alarm device) to the output relays, there will be a high surge voltage created while the inductor is turning on and off. If you do not connect reverse diode, the surge voltage will transfer and damage to the electronic circuit of the controller. It is strongly recommended to add a reverse diode between the inductor coils to absorb this surge voltage.

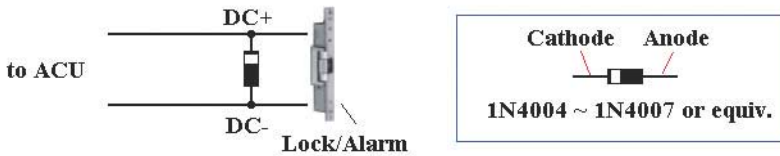

Fig.5 : Reverse Diode connection

**3-2-5. Reader connection**

If you install the reader in a long distance between the ACU and the reader, you have to remind that there will be a voltage drop between both ends of GND wire. For example, if you connect a reader with 100mA current consumption at 100m distance (assume to using DC resistance of cable of 100BY/100m) and the reader power is supplied from the ACU, the voltage drop of the GND wire will be 1V. In this case, Wiegand data signal can not be measured lower than 1V. The most of ACU is capturing the signal by the voltage level of data input and 1V is the critical point whether the ACU read the data logic "1" or logic "0" therefore the reader output can not be read correctly from the ACU.

You have to think about how you reduce the voltage drop between both ends of GND wire. There will be two method to reduce the voltage drop and ACU can read data correctly.

- 1) Reduce the DC resistance of GND wire; Using thick cable or add more wires to GND wire in parallel. If you connect 4 wires in parallel for GND, the DC resistance of GND wire will be reduced to 1/4 of single wire.
- 2) Use separate power for the reader; Disconnect +12V wire from the ACU and connect external power supply to the reader nearby then there will be no current flow through the GND wire and no voltage drop between both ends of GND wire.

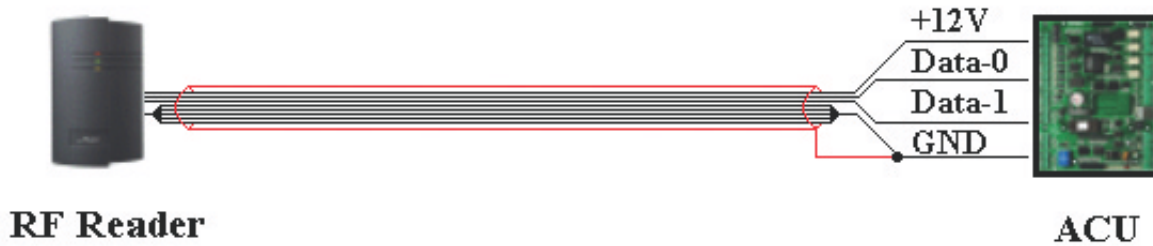

Fig.6 : Reader connection using additional wires

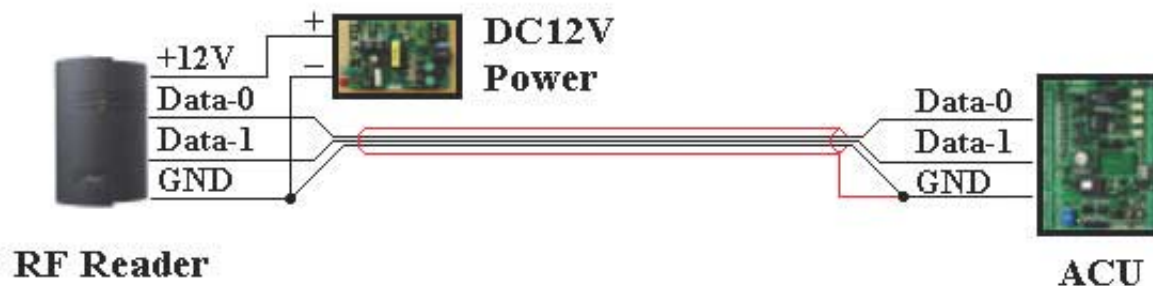

Fig.7 : Reader connection using external power supply

# Chapter 4

## **SERIAL COMMUNICATION SETUP**

## 4-1. CNP-200A (RS-232C TO RS-422/485 Converter)



### 4-1-1. Specification

- Convert RS-232C signal to RS-422/485 signal
- Dip switch for Multi-Drop or Point To Point communication set-up
- Built-in Terminal Resistance
- Built-in Surge Protector
- LED Display of status of power, RX, TX
- Power input : Free Voltage(AC 85V ~ AC 250V)
- In case of RS-485(half-duple) signal transmission RTS signal is to be ON(1), in case of receipt, RTS signal is to be OFF(0).

### 4-1-2. Composition

Connector	RS-232 (D-SUB 9P Male)		CRS-422 (D-SUB 9P Female)		RS-485 (D-SUB 9P Female)	
		2	RXD	1	TX -(White)	1
	3	TXD	6	TX +(Red)	6	TRX +(Red)
	7	RTS	2	RX -(Black)	2	N.C
	8	CTS	7	RX -(Blue)	7	N.C
	4	DTR	3	GND(Yellow)	3	GND(Yellow)
	6	DTS	8	N.C	8	N.C
	1	DCD	4	DC +12V(Green)	4	DC +12V(Green)
	5	GND	9	N.C	9	N.C
	9	N.C	5	N.C	5	N.C

## 4-2. Connection

### 4-2-1. Converter and controller connection

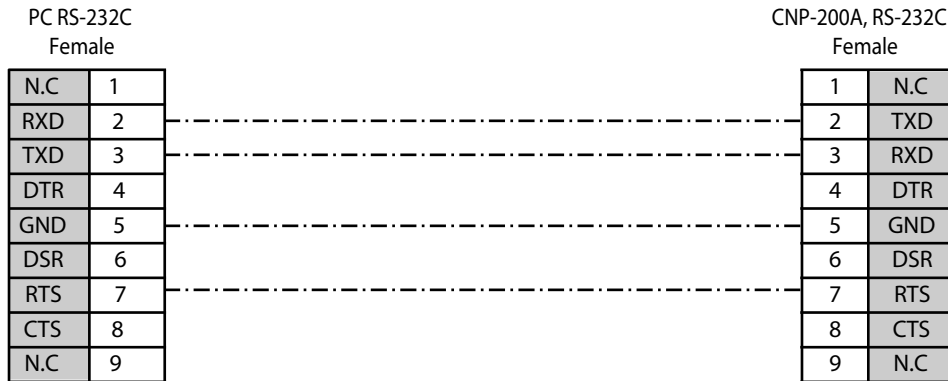

### 4-2-2. RS-422/485 Converter to iTDC/iCON100 Connection

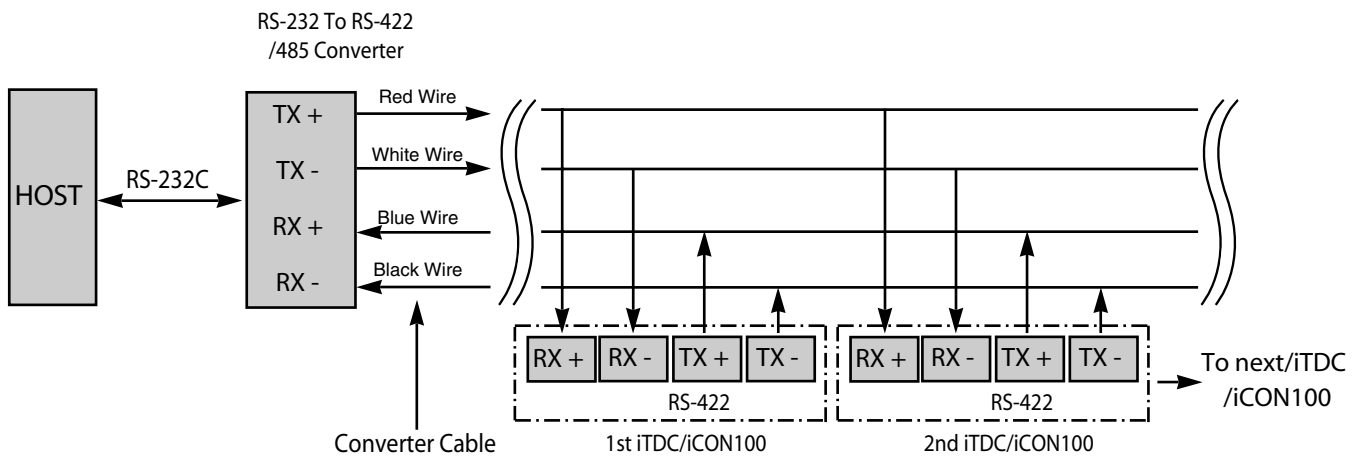

### 4-2-3. RS-422/485 Converter to 505R /Finger007 Connection

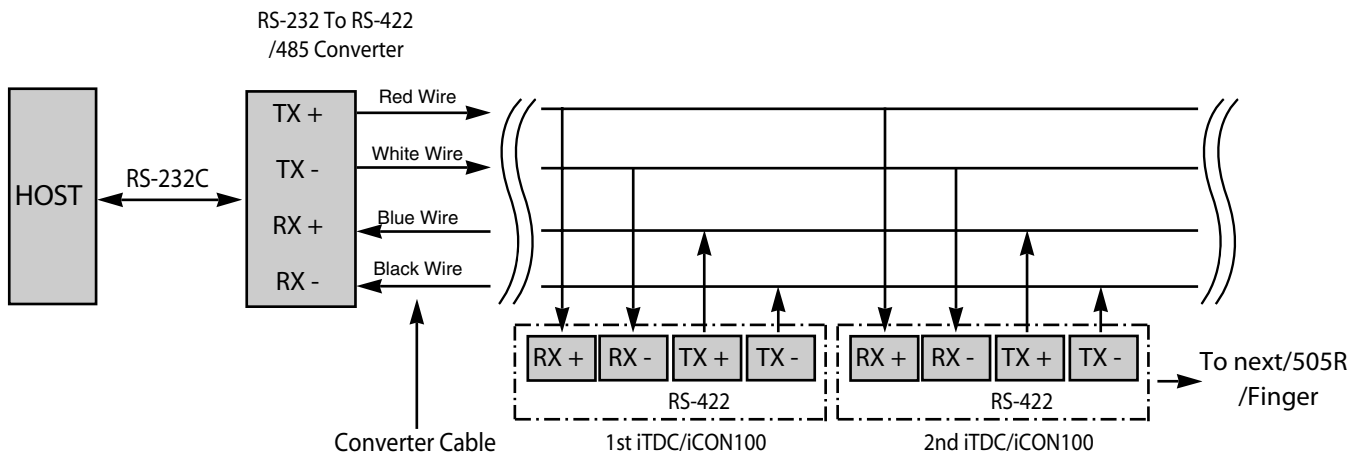

### 4-2-4. RS-232C Converter to Host Connection

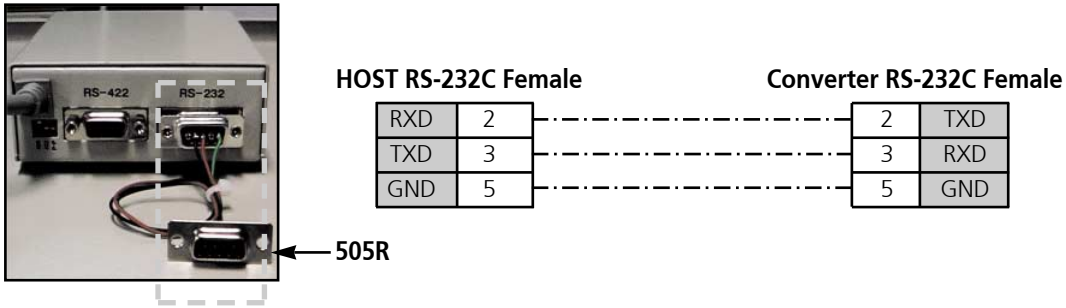

### 4-2-5. RS-422/485 Converter to NESS 505R/Finger007 Connection

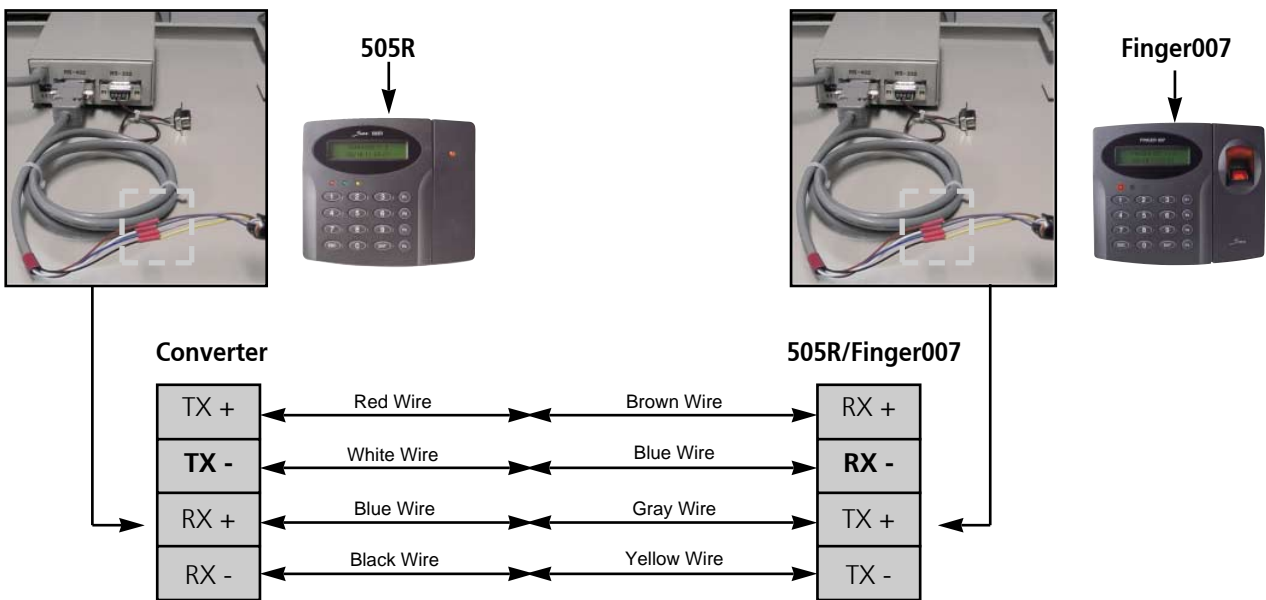

### 4-2-6. RS-422/485 Converter to NESS iCON100/iTDC Connection

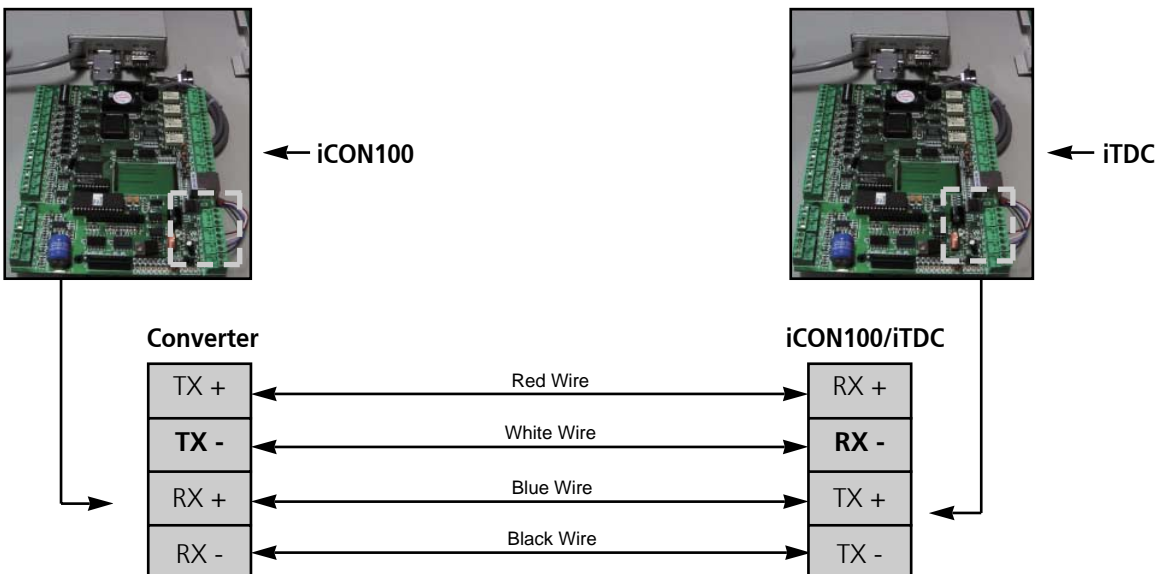

### 4-3. Multiple Communication Capability

- If using additional Multi-port device multiple communication is available
- Supported Ness Products : iTDC, iCON100, FINGER007, FGR006, 505

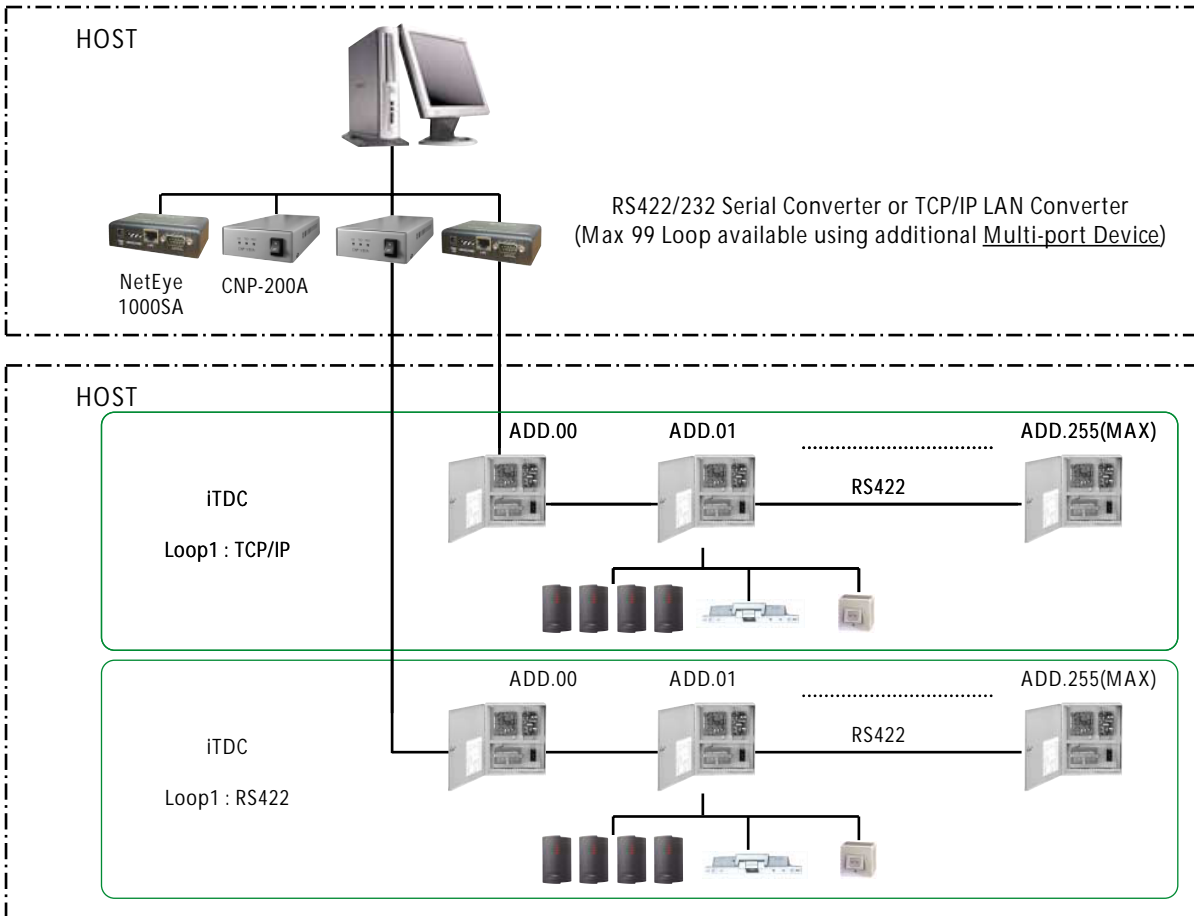

### 4-4. Software setup

- From the provided CD install the program. (Refer to provided Software Manual for installation procedure).
- Once installation is complete, click on Start button, scroll to Program then to Star505R, Finger007Ver4.0 (English) to start the program
- From the Login screen, input "Admin". Password is not needed for Login.

### 4-5. Communication type definition

- As shown below click on Database, then scroll to Option.
- From Option menu, select Serial Chain Type as Communication Type, then click OK to save..

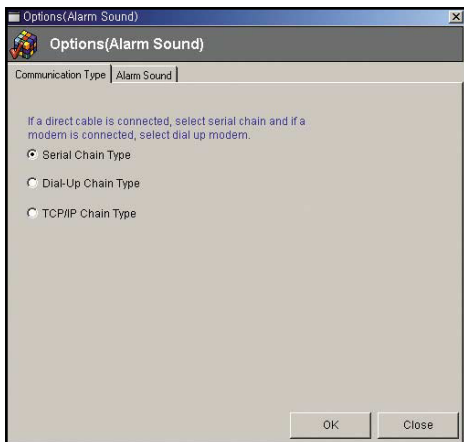

## 4-6. Serial chain communication definition

- Communication speed and communication port must be set in order to communicate with between 505R / FINGER007 system and installed program in computer by serial communication.

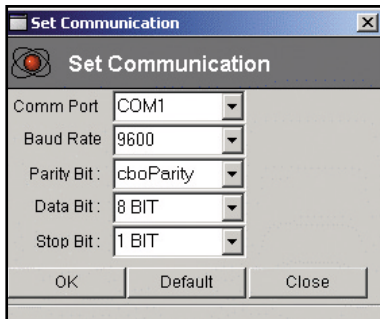

- Click 'Controller -> Set Serial Communication' in menu.
- Comm Port set communication port connected between 505R / FINGER007 system and computer. Defaulted value is COM1.
- Baud Rate set communication speed .between 505R / FINGER007 system and computer. Defaulted value is 9600bps.
- Parity Bit, Data Bit, Stop Bit use defaulted value.
- When communication setup is completed, click 'OK' button to save, then 'Close' button to exit.

**Default Button set all value defaulted.**

**Communication port is 'COM1', Communication speed is '9600', Parity bit is 'NONE', Data bit is '8 BIT', Stop bit is '1 BIT'. Usually, not change a basic value, uses defaulted value.**

## 4-7. System Definition

- Registers information of 505R / FINGER007 / ICON100 system.
- System definition is set both system address and system information in installed system. System address must be checked because system and program communicate with each other as system address. (Certification of system address refer to hardware (system) manual.).

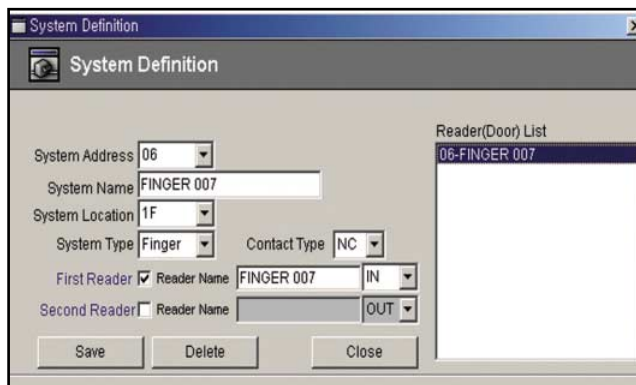

- System Address selects the same address of 505R / FINGER007 / ICON100 system.
- Usually to use one STAR 505R / FINGER007 system, System Address is '00' or '01'. To use several 505R / FINGER007 systems simultaneously, System Address is particularly set each system.
- System Name is the name of 505R / FINGER007 system.
- System Location selects location (floor in a building) of installed 505R / FINGER007 system.
- Contact Type selects Door Contact type installed Door Lock. By the Contact type, checks the gate status.
- Enter the name of First Reader, Second Reader.
- Also when a reader places the gate of coming in, it is the entry reader. Then selects 'IN'. When a reader places the gate of going out, it is exit reader. Then selects 'OUT'.
- Click 'Save' button to save.
- Click 'Delete' button after selecting the reader you want to delete on the right Reader (Door) List.

## 4-8. Serial Chain Communication Status

- As shown below click on Status, scroll to Communication Status to display communication status. If communication is successful, it will display as Image.

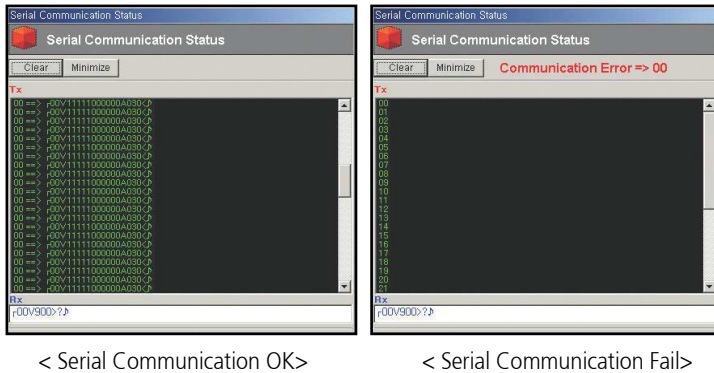

## 4-9. Reference : Problem of Communication

- Identify status of communication through 'Communication Status' after restarting program.
- If setting is finished correctly, you identify communication status of 505R / FINGER007 like following figure 1.

### FIGURE 1.

- When system isn't communicated, repeat previous procedures (Configuration).
- Identify whether address of 505R / FINGER007 device and program are equal.
- Identify whether Communication port of between 505R / FINGER007 system and computer are equal.
- Check a Converter whether to turn on or off power and to have matters when used Converter (RS422 -> RS232).

# Chapter 5

## LAN COMMUNICATION SETUP

## 5-1. LAN Communication via external converter

### 5-1-1. Check Items

Using the LAN converter with the (Finger007, 505R, or ICON100) will receive the following items as shown below (Figure. 1). This manual is written standard for the Finger007, as well as for the 505R application. In case of the ICON100, the configuration is very similar, and a H/W manual will be referred along with the above manual.

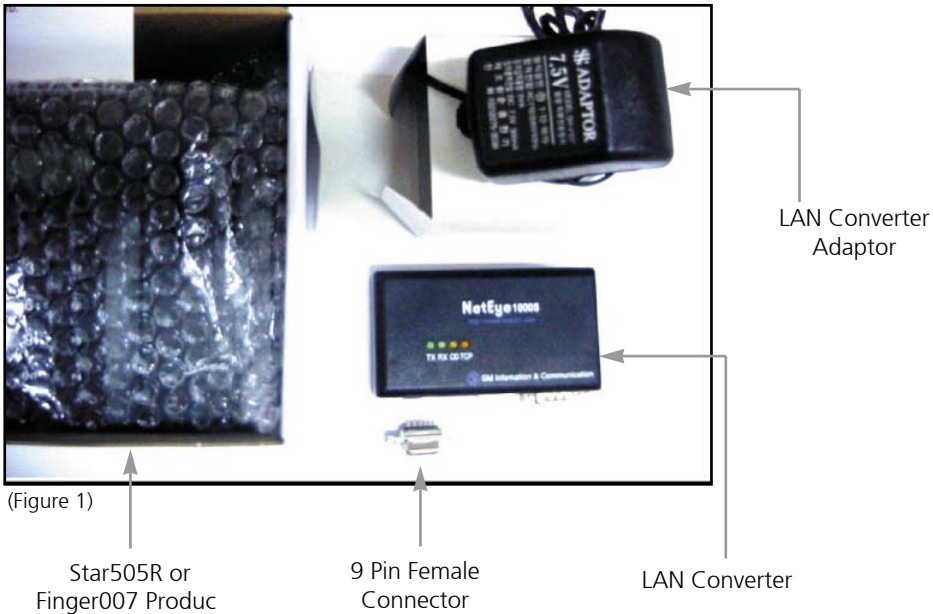

- 1) Item (Finger007, 505R, or ICON100)
- 2) LAN converter (NetEye1000S)
- 3) LAN converter adapter
- 4) 9 Pin Female Connector

### 5-1-2. Connection via RS232

#### Ness 505R, FINGER007 And 9 PIN Connector Wire Table

505R,FINGER007 WIRE	9 PIN CONNECTOR PIN CONNECTION
Black wire with White stripe(TXD)	Pin No 2 (RXD)
Red wire with White stripe(RXD)	Pin No 3 (TXD)
Black Wire(-)	Pin No 5 (GRD)

- a. As shown below (Figure 2), use the 2 wires (black w/white stripe and red w/white stripe) to attach to the 9 pin connector. You will need to obtain a separate ground wire for this setup. (not included)



(Figure 2)

b. As shown below (Figure 3) connect the separate ground wire to #5 on the 9 pin connector. (This is the wire you obtained separately) grounding wire is for the (-) negative connection.



(Figure 3)

c. As shown below (Figure 4) connect the black w/white stripe wire (Finger007 or 505R or ICON100) to #2 on the 9 pin connector.



(Figure 4)

d. As shown below (Figure 5) connect the red w/white stripe wire (Finger007 or 505R) to #3 on the 9 pin connector.



(Figure 5)

{ **Once the connection is finished, move on to the LAN converter setup section** }

**5-1-3. Connection via RS422**

**Ness 505R, FINGER007 and 9 PIN Connector Wire Table**

505R,FINGER007 WIRE	9 PIN CONNECTOR PIN CONNECTION
Gray wire(TX+)	Pin No 2 (RX+)
Brown wire(RX+)	Pin No 3 (TX+)
Yellow wire(TX-)	Pin No 7 (RX-)
Blue wire(RX-)	Pin No 8 (TX-)

a. As shown below (Figure 6), use the gray, blue, yellow, and brown wire to connect to the 9 pin connector.



(Figure 6)

b. As shown below (Figure 7) connect the gray wire to #2 on the 9 pin connector.



(Figure 7)

c. As shown below (Figure 8) connect the brown wire to #3 on the 9 pin connector.

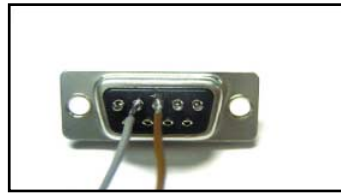

(Figure 8)

d. As shown below (Figure 9) connect the yellow wire to #7 on the 9 pin connector.

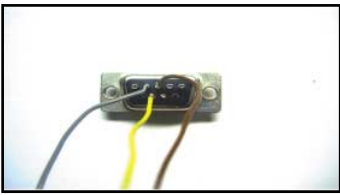

(Figure 9)

e. As shown below (Figure 10) connect the blue wire to #8 on the 9 pin connector.

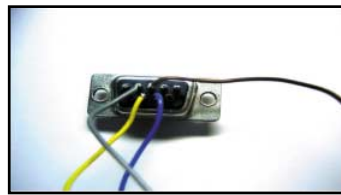

(Figure 10)

{ **Once the connection is finished, move on to the LAN converter setup section.** }

### 5-1-4. Lan Converter Setup

#### Switch Setup

a. Connection via RS232

Connection via RS232 will require the following Piano Switch setup as shown below (Figure 11) and table.



(Figure 11)

SWITCH NO	SWITCH STATUS
1	On(Down)
2	Off(Up)
3	On(Down)
4	Off(Up)
5	On(Down)
6	Off(Up)

b. Connection via RS422

Connection via RS422 will require the following Piano Switch setup as shown below (Figure 12) and table.



(Figure 12)

SWITCH NO	SWITCH STATUS
1	Off(Up)
2	On(Down)
3	Off(Up)
4	On(Down)
5	Off(Up)
6	On(Down)

Once the switch setup is completed, connect the power adapter, Ethernet (RJ45), and 9 pin connector to the LAN converter.

The picture shown below (Figure 13) is all the wiring completed with the (+) Red wire and (-) Black wire connection for power to (Finger007, 505R).



(Figure 13)

### LAN Converter IP Setup (Ness NetEye1000S setup program use)

CD is provided for LAN converter IP setup and checking communication activity. The application program is installed for the IP setup from the PC to LAN converter

#### a. Setup Program Install

- I. To begin installation, find the NetEye1000\_Setup.exe in the CD and click on it.
- II. As shown below (Figure 14) begin installation. Click "Next" button to move to next step.



(Figure 14)

As shown below (Fig. 15) find the folder to install into and click "Install" button to start installation.



(Figure 15)

V. As shown below (Figure 16) installation begins and will be completed in a few moments. Click "OK" to complete the installation.



(Figure 16)

**b. Setting Up IP with Setup Program.**

Upon program install completion, click on Start button, scroll to Program then to NetEye1000 to start the program.

Once the program starts as shown below (Figure 17), all the LAN converters' information connected to the same network is displayed.

The following displays 2 LAN converters connected to the same network.

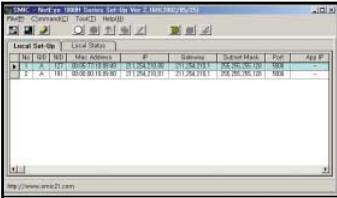

(Figure 17)

As shown below (Figure 18) each LAN converter needs to setup the IP, Gateway, Subnet Mask, and Port.

From display (Figure 17) clicking twice on the highlighted LAN converter to setup will popup setup screen below

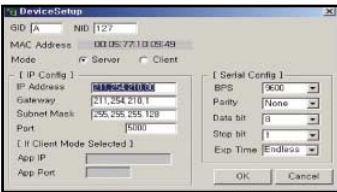

(Figure 18)

User needs to setup category (Mode, IP address, Gateway, Subnet Mask, Port, BPS, parity, Data bit, and Stop bit).

ITEM	VALUE
Mode	Server
IP Address	IP address given by Network (No able to be duplicated)
Gateway	Value given by Network
Subnet Mask	Value given by Network
Port	5000
BPS	9600
Parity	None
Data bit	8
Stop bit	1

**C. Remote Set-up with Setup Program**

Remote Enable: Click the remote enable Button to enable remote setting menu, you can see Password Input Box. Default Password is "smicneteye". Type the password and click OK button, Now you can change the password.

Remote Enable : Enable remote mode.

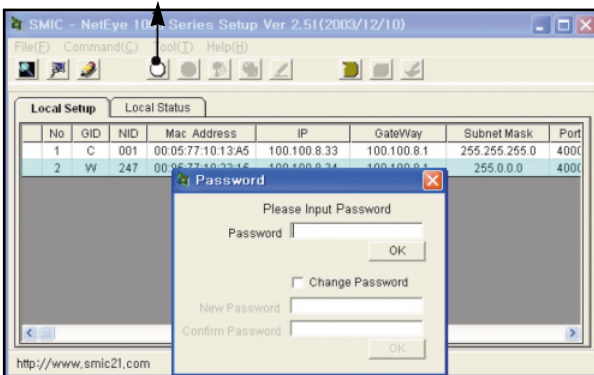

Remote buttons will be enabled and remote set-up file folder is added on the screen

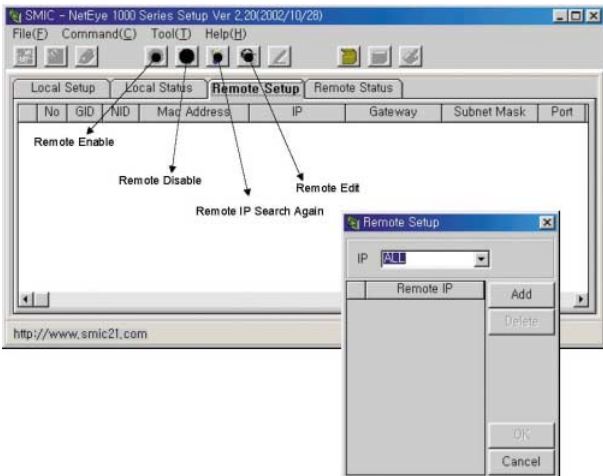
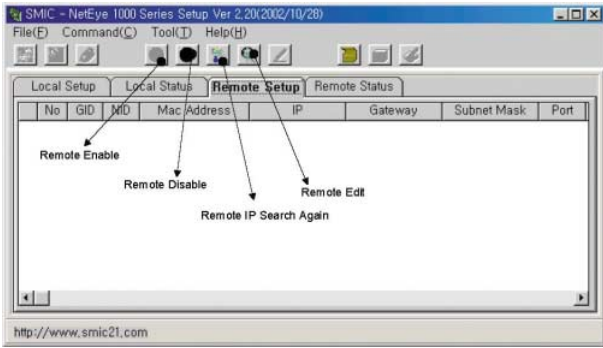

If you click the remote search IP button, Remote Setup Box will be displayed. Type the remote NetEye IP address and click Add button. You can input multiple remote NetEyes IP addresses. When you click OK button, It searches remote NetEyes and display them on the screen.

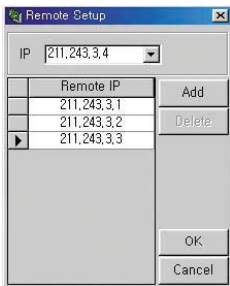

**5-1-5. Software Setup**

From the provided CD install the program. (Refer to provided Software Manual for installation procedure).

Once installation is complete, click on Start button, scroll to Program then to Star505R, Finger007Ver4.0 (English) to start the program

From the Login screen, input "Admin". Password is not needed for Login.

As shown below (Figure 19) click on Database, then scroll to Option. From Option menu, select TCP/IP Chain Type as Communication Type, then click OK to save.



(Figure 19)

As shown below (Figure 23), follow the instructions below to setup.

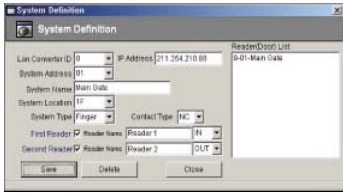

(Figure 20)

On the LAN converter Device Info (Figure 21), follow the instructions below to setup.

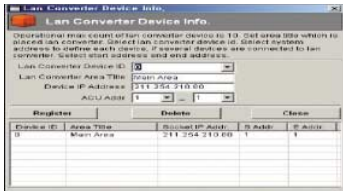

(Figure 21)

Select the LAN converter Device ID. (The maximum number of LAN converters able to connect to the same network is 10 units. One LAN converter’s maximum connectivity is 32 units.)

In case of one LAN converter set the Device ID as ‘0’, with two units set it as ‘0’ and ‘1’. It is used to identify the LAN converters, so increase the value with the LAN converters in use.

Input LAN converter Area Title as location of LAN converter installed. Also, the device operating the area connected to the LAN converter can be inputted as optional.

Input Device IP Address as same IP value setup in NetEye1000S program.

Input ACU Addr as the start and finish address of the units connected to the LAN converter. (When using one LAN converter with one device as RS232, one device is connected. When using RS422, a maximum of 32 devices can be connected for use).

Click on Register button to save the related information, then click on Close button to close

As shown below (Figure 22) click on Database, scroll to System Definition.

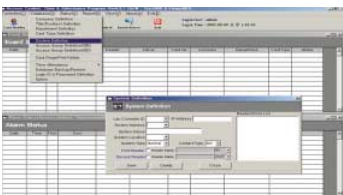

(Figure 22)

Select the LAN converter ID value setup in LAN converter Device Info. Setup IP Address value is shown in the right side IP Address (Figure 23).

Select the System Address correlating to the LAN converter Device ID connected to the System Address.

Input System Name.

Select System Location. For System Type, select Normal for 505R and Finger for Finger007.

Select First Reader, Second Reader and input related information.

When above procedures are completed, close the program then restart. After restart, if all related setup is correct, you can check communication status.

As shown below (Figure 23), follow the instructions below to setup.

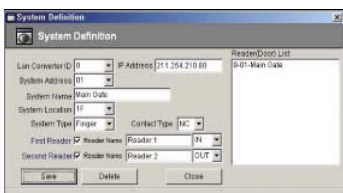

(Figure 23)

As shown below (Figure 24) click on Status, scroll to Communication Status to display communication status.

If communication is successful, it will display as (Figure 24).

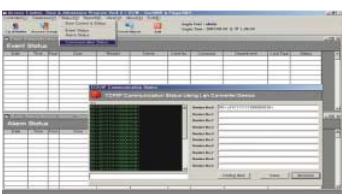

(Figure 24)

## 5-2. LAN Communication via internal module of the Ness iTDC

### 5-2-1. Internal Module Configuration Program using IGM7100 Tool

Click Start->Program->IIM7100tool->IIM\_Cfgtool to run program.

Check the selected module’s IP, Subnet, Gateway, Speed, Parity, Data Bit, Stop Bit, Flow, and Listen Port then modify if necessary. Also, you must use Server Mode for Mode Selection.

- a. Board Serial Configuration : Speed, Parity, Data Bit, Stop bit, Flow must be set below (Figure 1) and (Figure 2).
- b. Mode Selection : Listen Port is “5000”(a fixed value). Refer below (Figure 1) and (Figure 2).

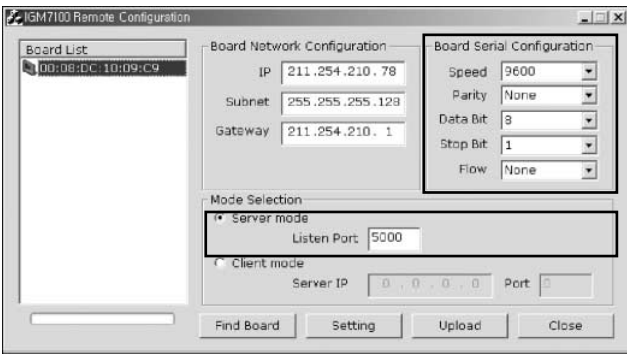

(Figure 1)

Category	Configuration Value
Mode	Server mode
IP Address	IP Address received from network(No Duplication)
Gateway	Gateway received from network
Subnet Mask	Subnet Mask received from network
Listen Port	5000
BPS	9600
Parity	None
Data bit	8
Stop bit	1

(Figure 2)

### 5-2-2. Software Configuration (using Ness STARWATCH Pro iTDC)

Click System -> Port Definition or press shortcut key Ctrl+A. Then, click Add or Modify button, and the following screen appears.

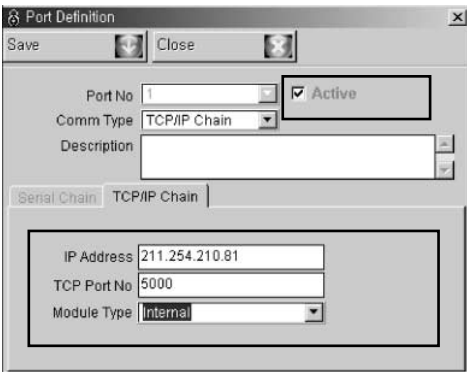

(Figure 3)

Check the comm. type, IP Address, TCP Port No, Module Type, then modify if necessary.

- a. Active item must be checked.
- b. IP Address: Input IP Address registered IIM7100 Remote Configuration.
- c. TCP Port No: This is “5000”(a fixed value).
- d. Mode Type: you must use Internal.

**Reference**

In case that its communication would not be on, although all the setting is made correctly, please check if the network is blocked by firewall.

# Chapter 6

## **DIAL-UP COMMUNICATION SETUP**

## 6-1. Dial-Up Communication

### 6-1-1. Required Systems

1. 3Com U.S Robotics 56K Fax External Modem 2sets (Remote Site, Host Site)
2. RS422 to RS232 Converter 1ea
3. Host, Remote Serial communication Cable 2pcs
4. Dial-Up Access Control Program(505R Software V1.5)
5. Host PC(PII-450 or Higher, Memory 128MB or Higher) 1set

### 6-1-2. Modem Configuration Setup

1. Host Site Modem Setup
  - 2) Connect Remote site Modem to serial port of host computer using a standard serial cable.
  - 3) Run Hyper Terminal program.
  - 4) Type "ATZ" and "Enter" from Hyper-terminal.
  - 5) If this Modem is successfully connected to Hyper Terminal then Modem will reply "OK" message.
  - 6) Type "ATS0=1" and "Enter" then confirm the modem reply "OK" message.
  - 7) Type "AT&W" and "Enter" then confirm the modem reply "OK" message.
  - 8) Now this modem is setup 9600 baud rate, Auto-receive mode and stored this setup into modem register.
  - 9) Disconnect modem from the host computer then connect this modem to remote site only.
2. Remote Site Modem Setup

### 6-1-3. Serial Interface Pin Definitions

DB-25	DB-9	Circuit	Function	Signal Source Computer /Modem
1	-	AA	Chassis Ground	Both
2	3	BA	Transmitted Data	Computer
3	2	BB	Received Data	Modem
4	7	CA	Request to Send	Computer
5	8	CB	Clear to Send	Modem
6	6	CC	Data Set Ready	Modem
7	5	AB	Signal Ground	Both
8	1	CF	Carrier Detect	Modem
12	-	SCF	Speed Indicate	Modem
20	4	SD	Data Terminal Ready	Computer
22	9	CE	Ring Indicate	Modem

### 6-1-4. Serial Cable Configuration

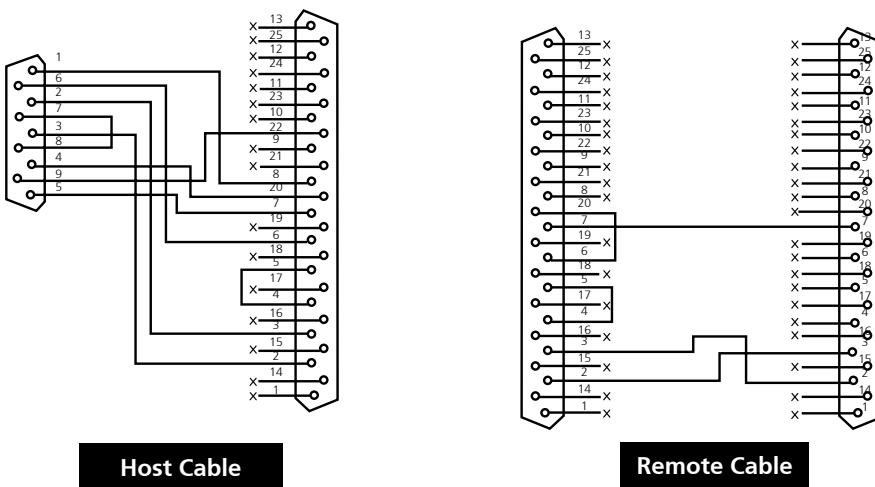

## 6-2. Host Cable Connection

- Connect host cable as below referring 4. Serial cable configuration of the previous page.
- Connect DB 9 to COM1 Port of PC.
- Connect DB25 to 25 Pin Port of Dial-up Modem.

### 6-2-1. Connect DB9-1 to DB25-8.

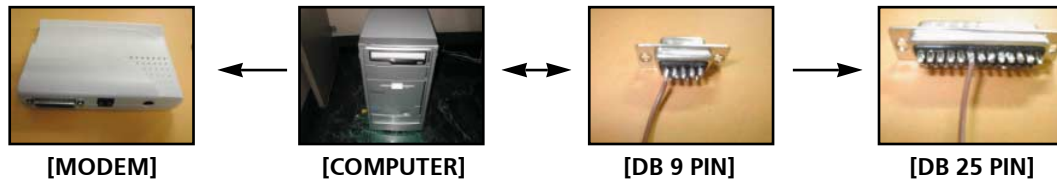

### 6-2-2. Connect DB9-2 to DB25-3.

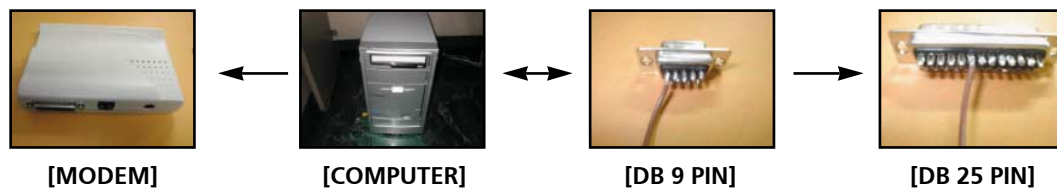

### 6-2-3. Connect DB9-3 to DB25-2.

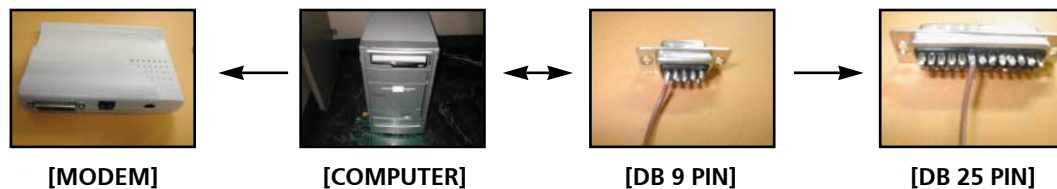

### 6-2-4. Connect DB9-4 to DB25-20.

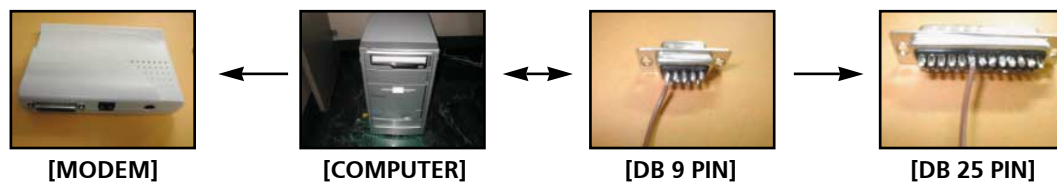

### 6-2-5. Connect DB9-5 to DB25-7.

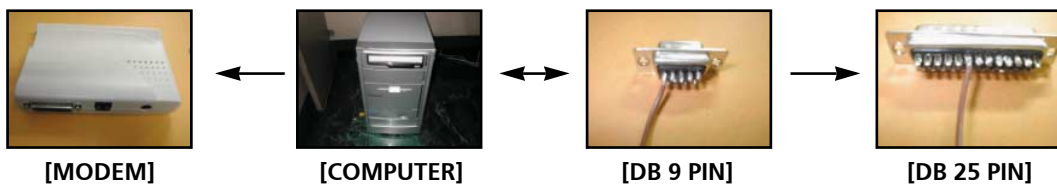

### 6-2-6. Connect DB9-6 to DB25-6.

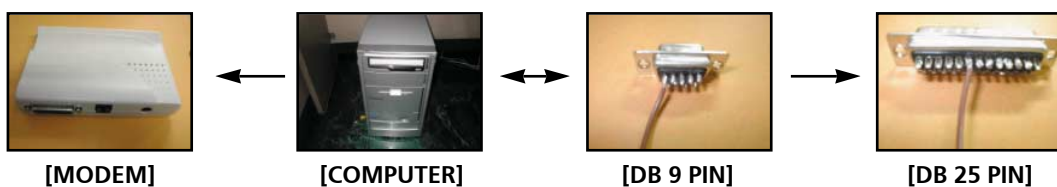

**6-2-7. Connect DB9-9 to DB25-22.**

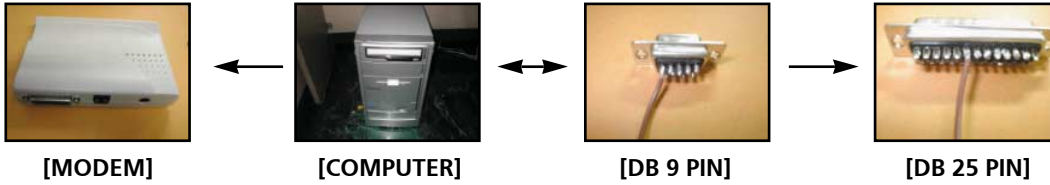

**6-2-8. Connect DB9-5 to DB9-6.**

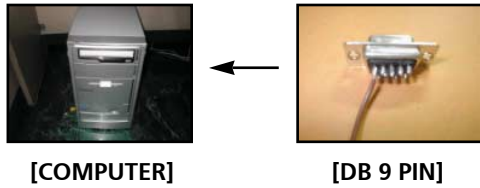

**6-2-9. Connect DB9-9 to DB25-22.**

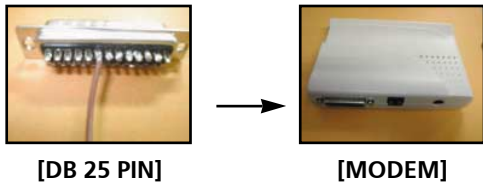

**6-3. Remote Cable Connection**

- Connect Remote cable as below referring 4. Serial cable configuration .
- Connect DB 9 to RS232C Port of CONVERTER..
- Connect DB25 to 25 PIN PORT of MODEM.

**6-3-1. Connect DB9-2 to DB25-3.**

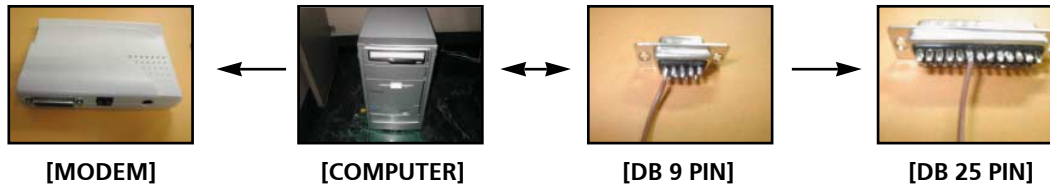

**6-3-2. Connect DB9-3 to DB25-2.**

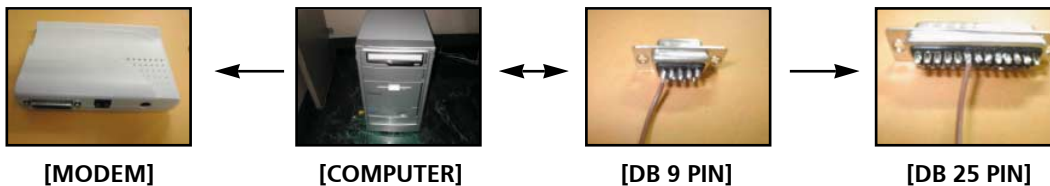

**6-3-3. Connect DB9-5 to DB25-7.**

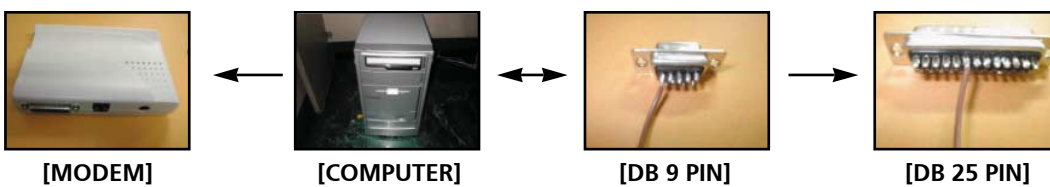

6-3-4. Connect DB25-4 to DB25-5

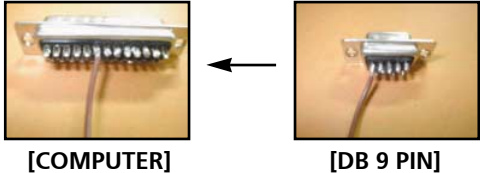

6-3-5. Connect DB25-6 to DB25-20

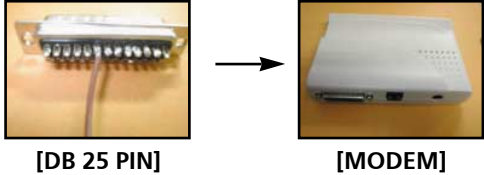

6-4. Dial-up Modem Connection

- Connect Dial-up modem referring 7. Dial-up Modem Connection Flow Diagram as below.

6-4-1. Dial-up Modem Connection Flow Diagram

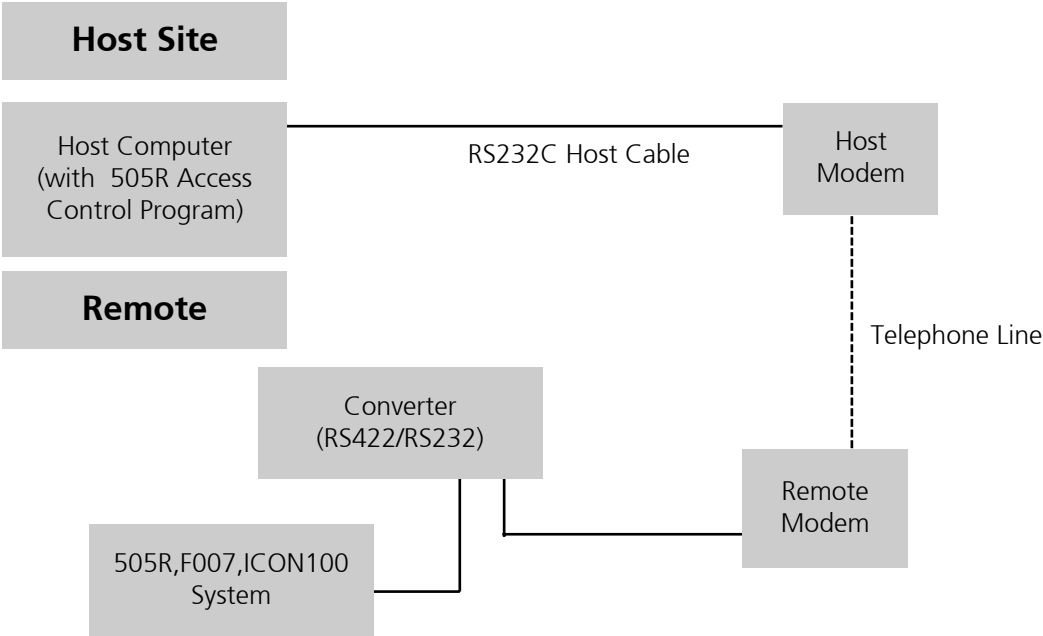

6-4-2. Connect DB9 PIN-A to COM Port of PC.

**6-4-3. Connect DB25 PIN-A to HOST MODEM.**

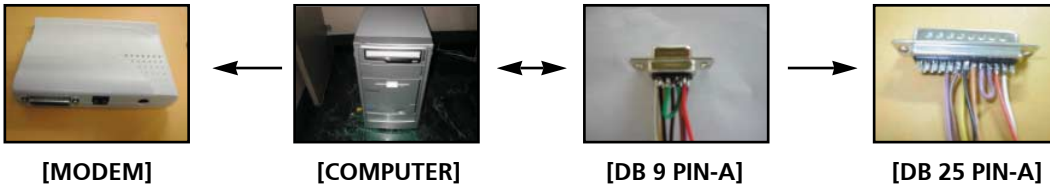

**6-4-4. Connect via telephone HOST MODEM and REMOTE MODEM.**

**6-4-5. Connect DB25 PIN-B to REMOTE MODEM.**

**6-4-6. Connect DB9 PIN-B to CONVERTER.**

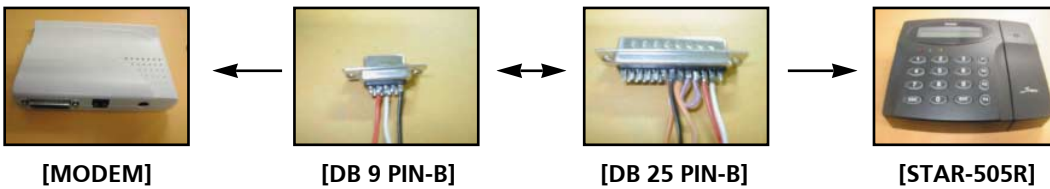

**6-5. Software Setup**

From the provided CD install the program. (Refer to provided Software Manual for installation procedure).

Once installation is complete, click on Start button, scroll to Program then to Star505R, Finger007Ver4.0 (English) to start the program

From the Login screen, input "Admin". Password is not needed for Login.

As shown below (Figure 1) click on Database, then scroll to Option. From Option menu, select Dial-Up Chain Type as Communication Type, then click OK to save.

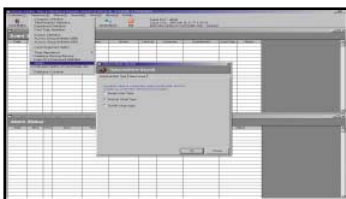

(Figure 1)

As shown below (figure 2) click on Controller, then scroll to Dial-Up Connection. Click this menu.

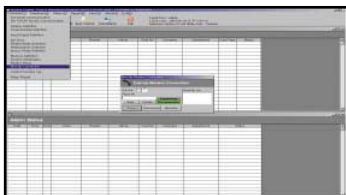

(Figure 2)

On the Dial-Up Modem Connection Info (Figure 3), follow the instructions below to setup.

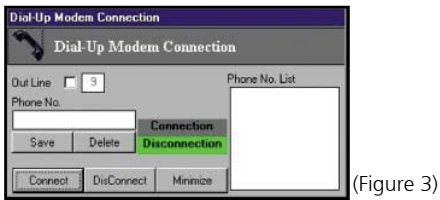

(Figure 3)

In case of using external line, checks Out Line Option, then inputs out Line number.(Defaulted value is "9")

After input Phone number to receive in Phone No. filed, click "Save" button.

To try to call by modem when to call input or selected phone number, click "Connect" button.

To disconnect, click "DisConnect" button.

As shown below (Figure 4) click on Database, scroll to System Definition.



(Figure 4)

As shown below (Figure 5), follow the instructions below to setup.

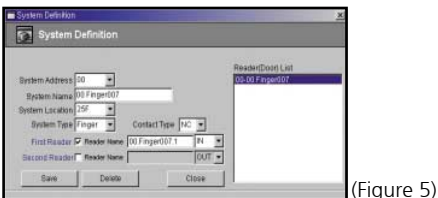

(Figure 5)

Select the System Address.

Input System Name. Select System Location.

For System Type, select Normal for 505R and Finger for Finger007.

Select First Reader, Second Reader and input related information.

When above procedures are completed, close the program then restart. After restart, if all related setup is correct, you can check communication status.

# Chapter 7

## **DOOR LOCK INSTALLATION**

## 7-1. The Installation of Ness Electro Magnetic Lock

- Door can be opened and closed just to one side direction in case of EM Lock.
- In case of Outswing install as follow No.1
- In case of Inswing install as follow No.2 and in this case you have to add L&Z Bracket.
- Card reader or Exit button can be used for Exit.

### 7-1-1. How to install in Single Door (Iron frame door, Wood door, Glass door)

a. Outswing Door Open

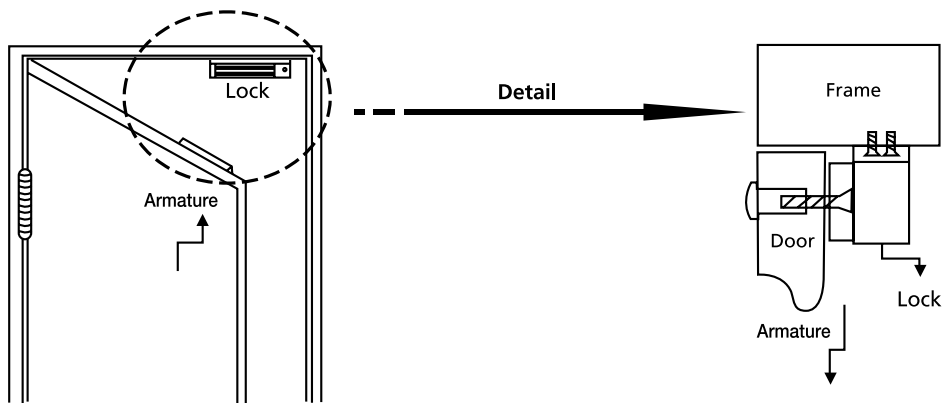

b. Inswing Door Open

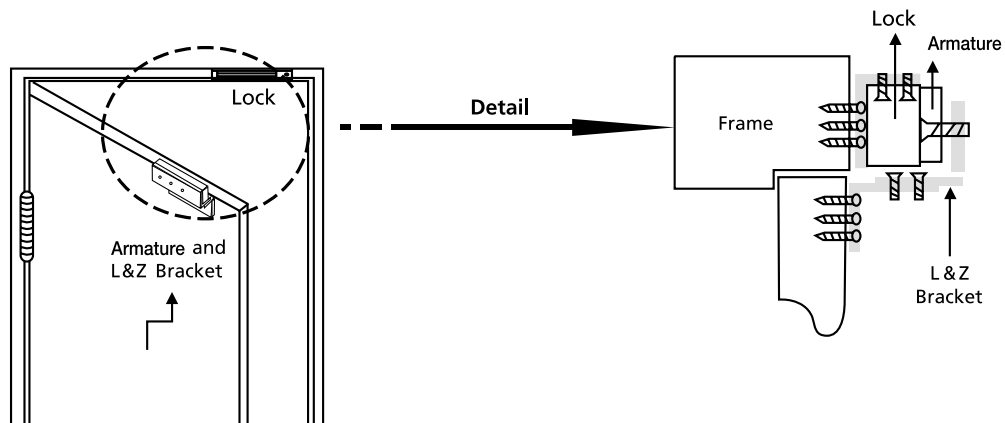

7-1-2. How to Install in Double Door (1 Lock) (Fire Protection Door, Wood Door, Glass Door)

a. Outswing Door Open

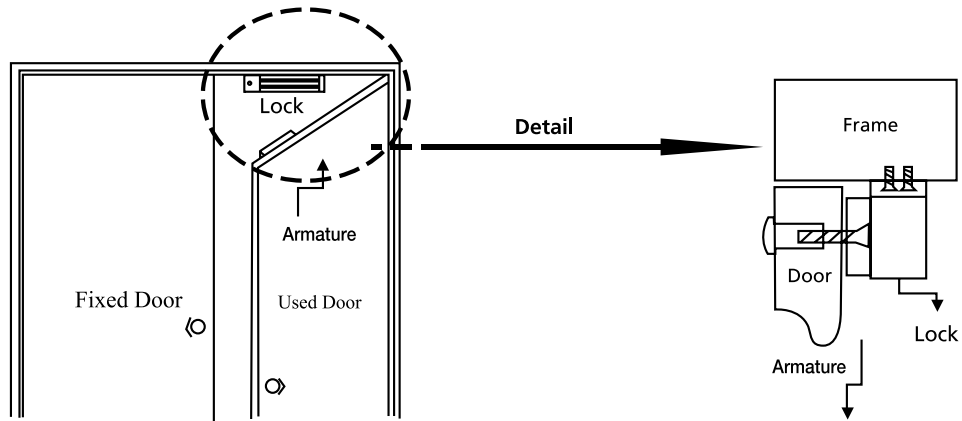

- “L” Bracket : It is used in “Outswing Door”  
It is used in case difficult to install EM lock in door frame

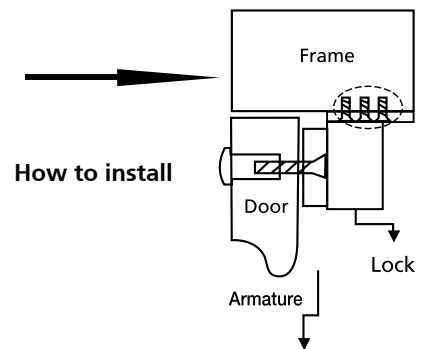

b. Inswing Door Open

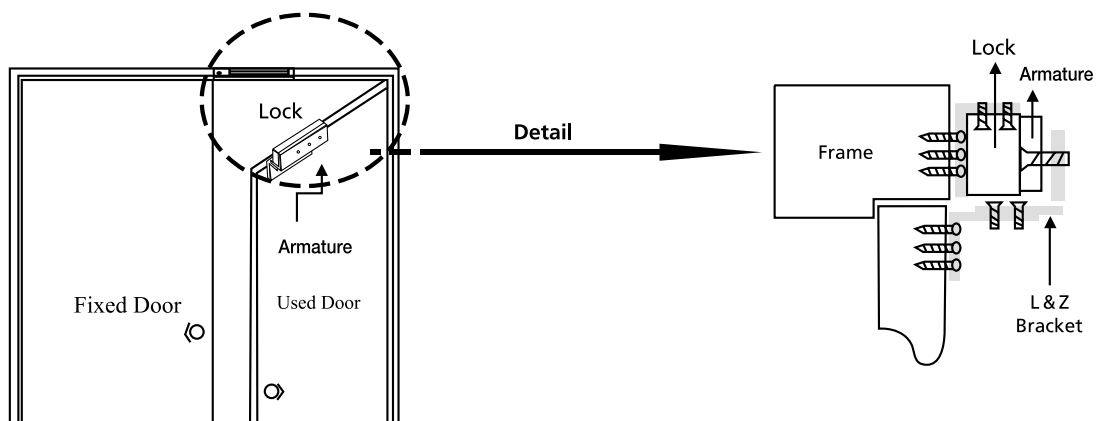

### 7-1-3. How to Install in Double Door (2 Lock) (Fire Protection Door, Wood Door, Glass Door)

#### a. Outswing Door Open

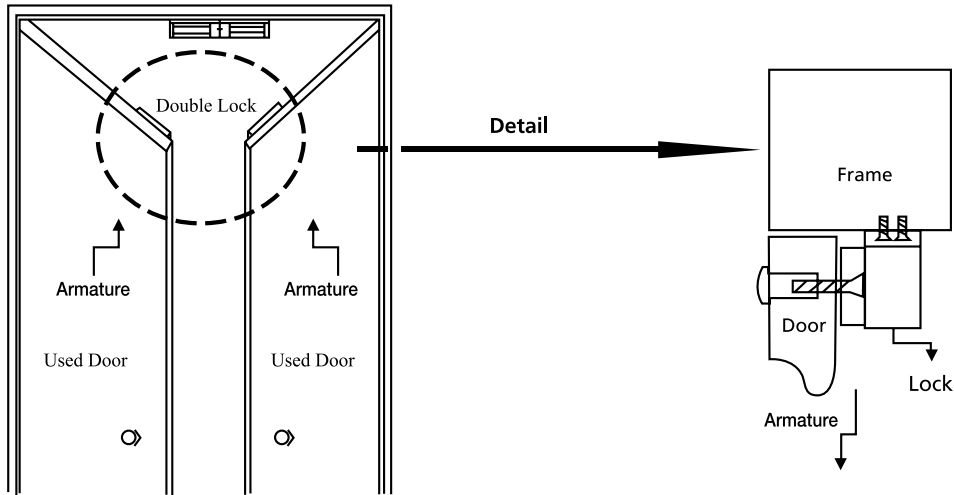

#### b. Inswing Door Open

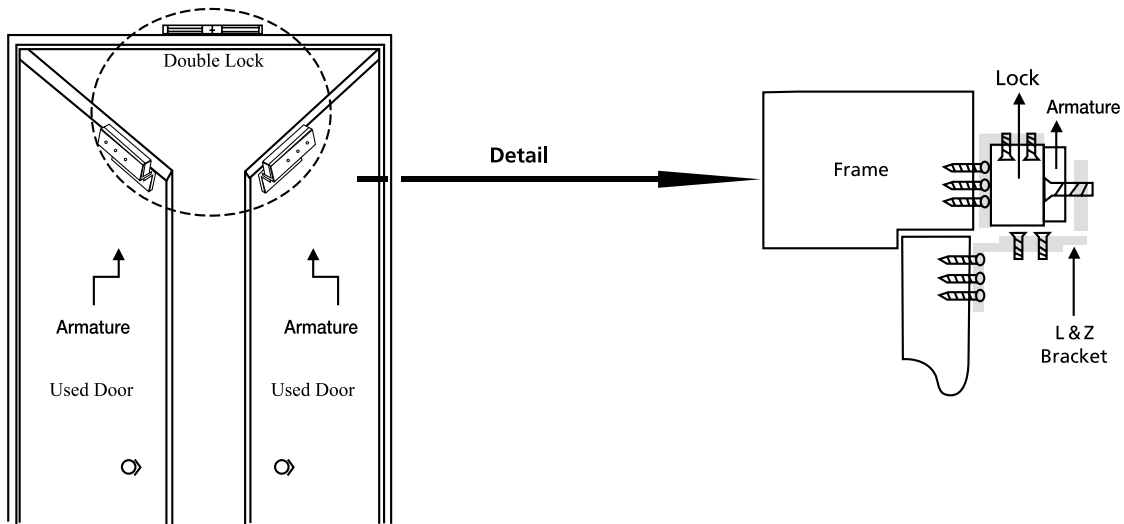

7-1-4. How to Install in Double Door(2 Lock)(Fire Protection Door, Wood Door, Glass Door)

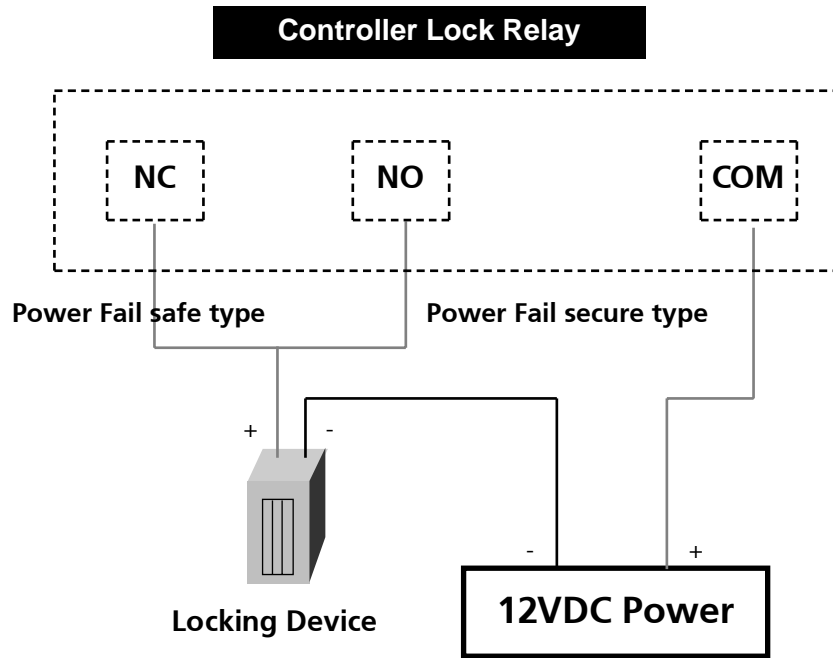

<Connection>

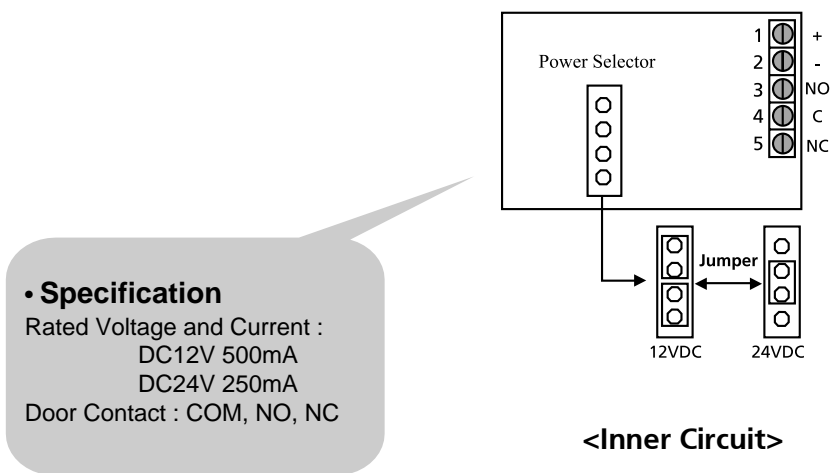

<Inner Circuit>

## 7-2. The Installation of Ness Deadbolt Lock

- It is installed in Tempered Glass Door.
- Door can be opened and closed to both sides in case of Deadbolt Lock
- Card reader or Exit button can be used for Exit.
- If frame is not existed at the top or bottom of glass, by using deadbolt case for glass door it can be installed by sticking to glass.
- If frame is existed just at the bottom of glass, it is installed by using an exposed case.

### 7-2-1. How to Install in Double Door(2 Locks) (Tempered Glass Door)

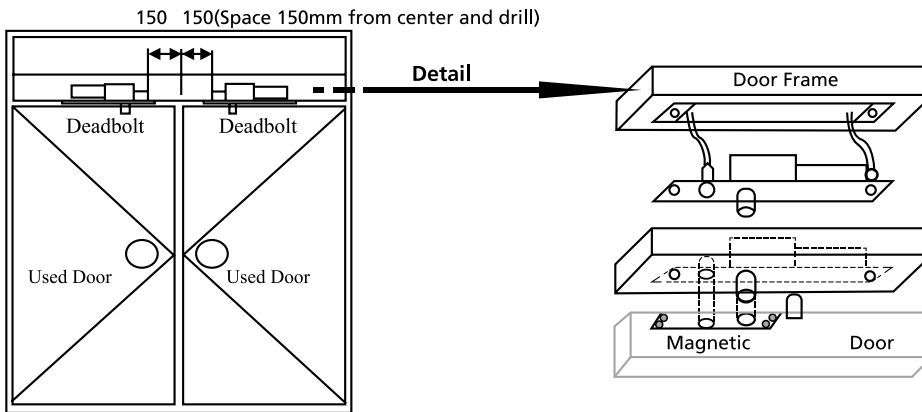

### 7-2-2. How to Install in Double Door(1 Lock)(Tempered Glass Door)

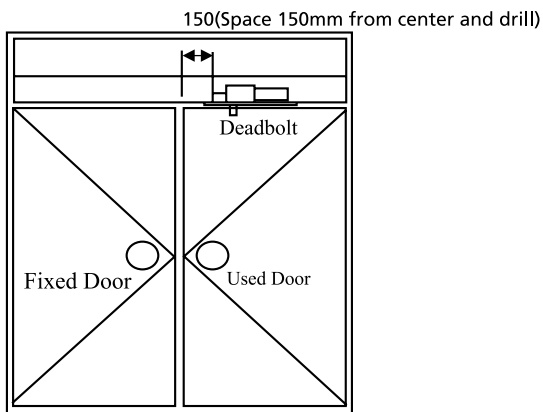

**7-2-3. How to Install in Single Door (tempered glass door)**

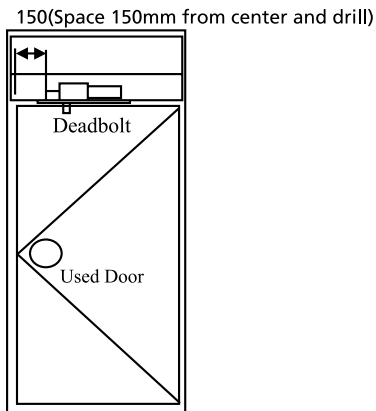

**7-2-4. How to install Deadbolt Case for glass without frame at the top of door (tempered glass door)**

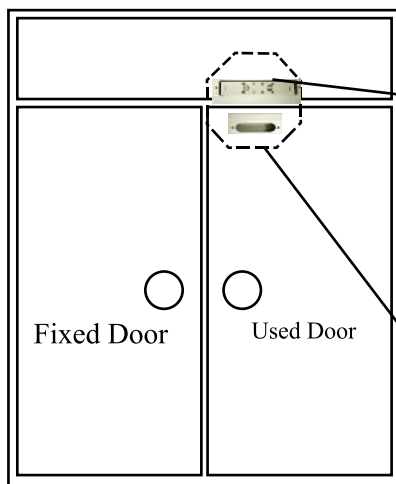

- Open type Deadbolt Case for glass only

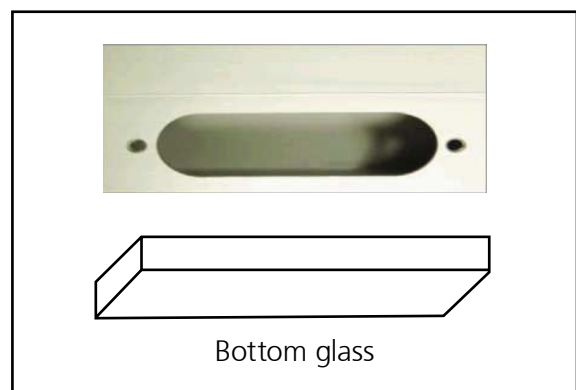
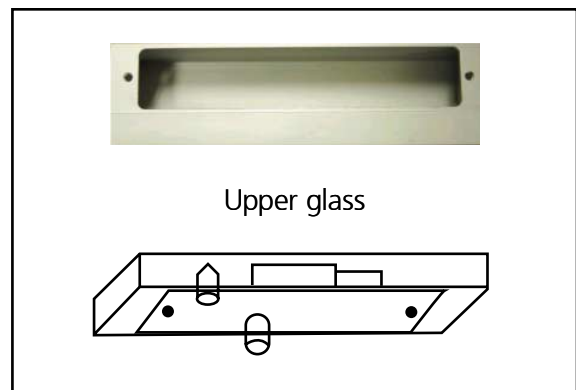

**7-2-5. How to Install Deadbolt Case in case frame is existed just at the bottom of door (tempered glass door)**

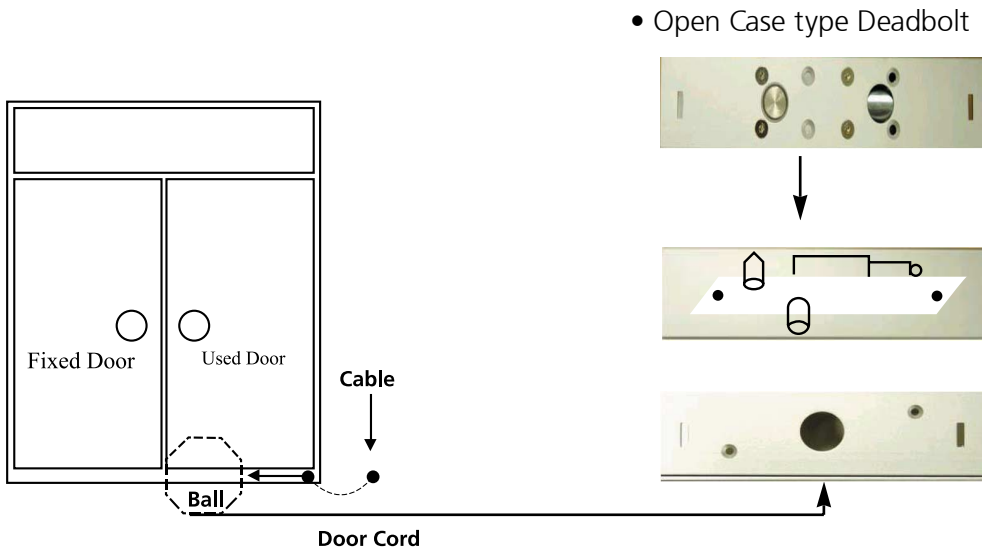

**7-2-6. Drawing and Inner Circuit**

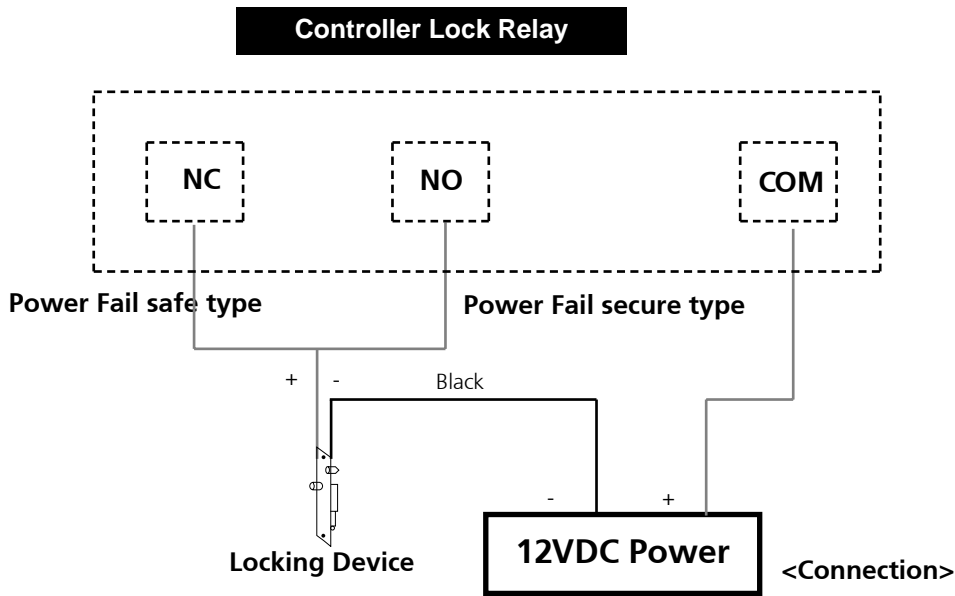

**• Specification**

Rated current and voltage:  
DC12V 700mA  
Door Contact : COM(yellow),  
NO(green), NC(violet)  
Time : 1s, 2s, 3s, 4s, 8s

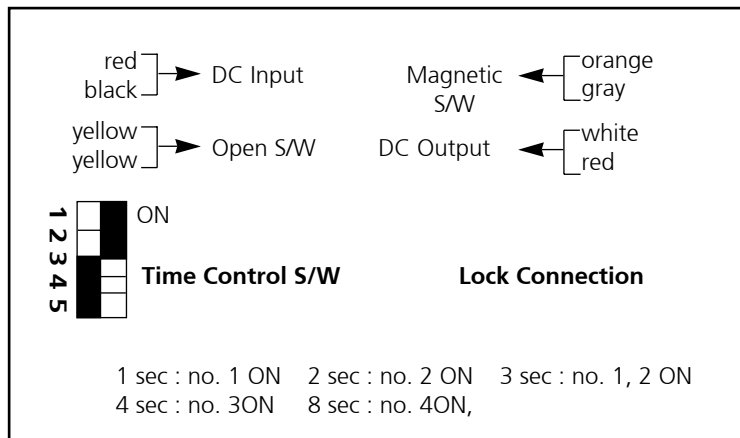

### 7-3. The Installation of the Ness Electric Strike Lock

- Electric Strike Lock has to be installed at inswing door type.  
For access control purpose lock has not to be opened outside.
- Able to open the door by trundling cylinder of lever on exit.  
If you intend to exit by using card reader or exit button, cut the wing of latch for locking to both sides cylinder & lever.

#### 7-3-1. How to install in Single Door (fire protection door, wood door)

##### a. Single Door

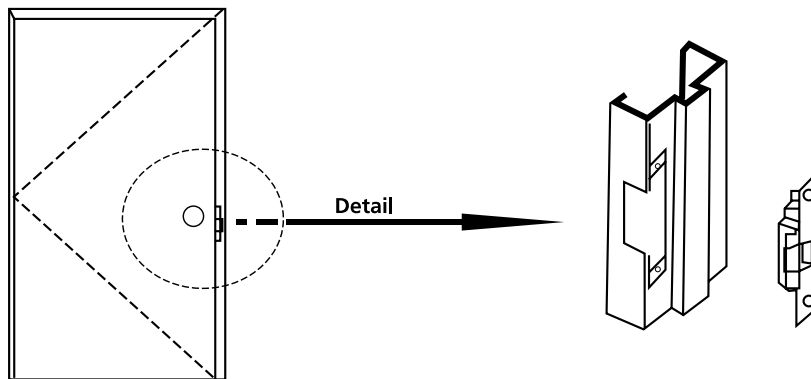

#### 7-3-2. How to install in Double Door (fire protection door, wood door)

##### a. Double Door

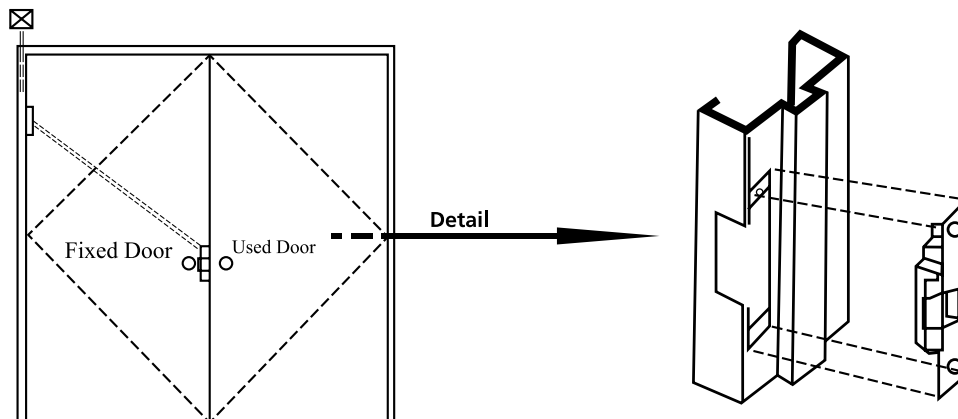

### 7-3-3. How to cut Cylinder & Lever Latch

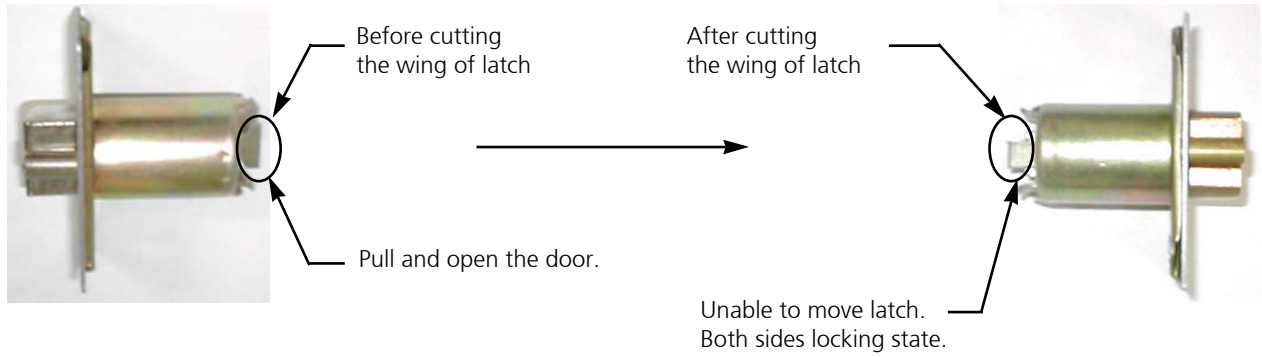

### 7-3-4. Line Drawing and Inner Circuit

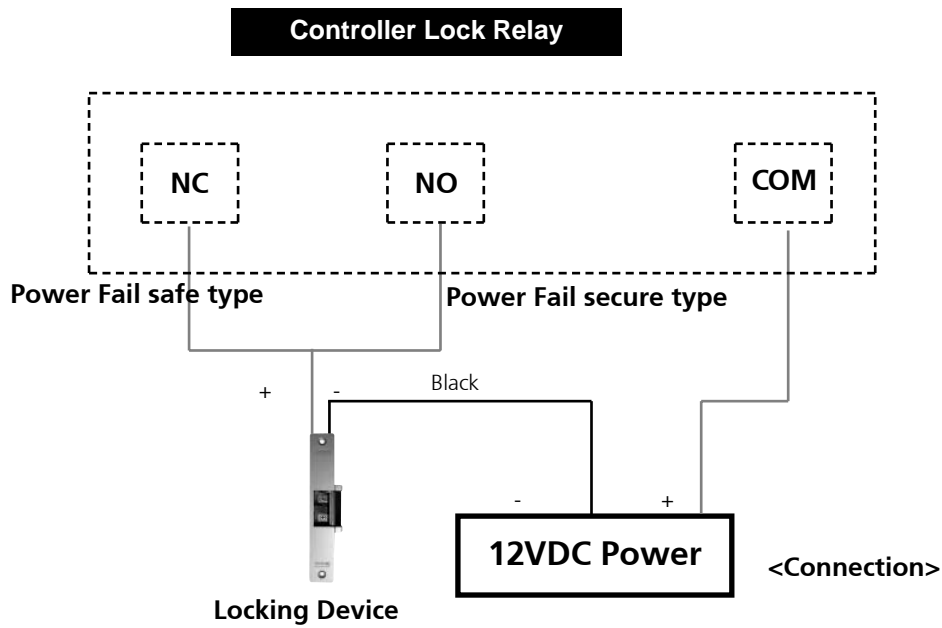

**• Specification**  
 Rated current and voltage :  
                                   DC12V 120mA  
 Door Contact : COM, NO

red black yellow  
(+) (-)

### 7-4. The Installation of Electronic Hinge(TEK-9)

- It is used in case of newly-built door, because hole has to be drilled before installation
- In Double Door it is installed between door frame of fixed door and door
- It is used just in Double Door
- It has the merit not exposed in the outside, because it is reclaimed
- In this case, connect lock cable with lock through electronic hinge(TEK-9)

#### 7-4-1. How to Install

##### a. Double Door

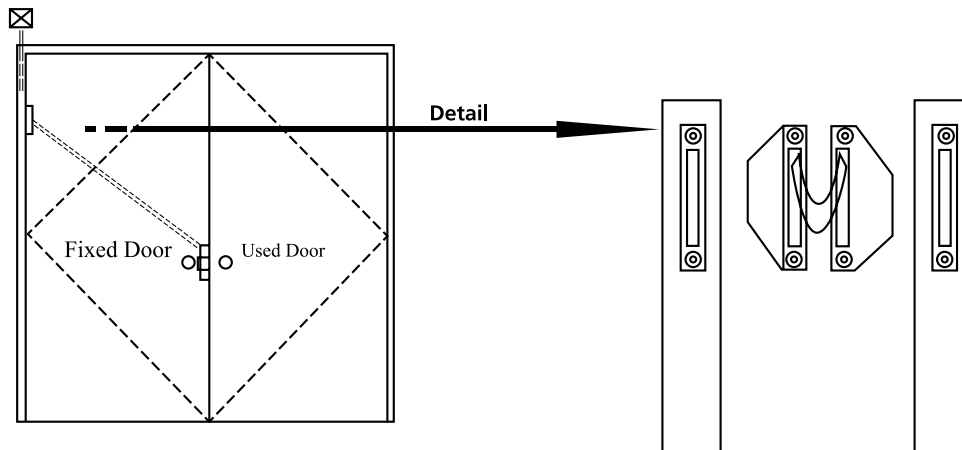

## 7-5. The installation of Door Cord

- Door Cord has to be installed between the door and the door frame of fixed door in Double Door.
- In this case connect lock cable with lock through Door cord.
- It is used in case that Door was already .
- It has to be installed indoors.

### 7-5-1. How to stick

a. Double Door

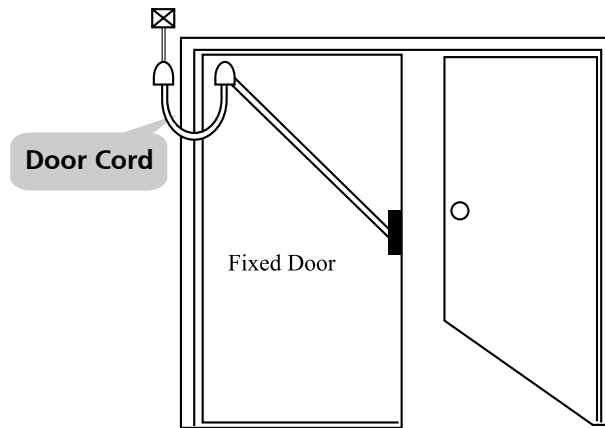

## 7-6. The Installation of Cylinder & Lever

- Cylinder Type : In this case Cylinder or Lever Type is used. If exit button is not installed for exit, you have to exit by using Cylinder & Lever.
- In case of Cylinder & Lever, outdoors key has to be install and indoors it has to be always locked without key.

### 7-6-1. How To Stick

a. Single Door

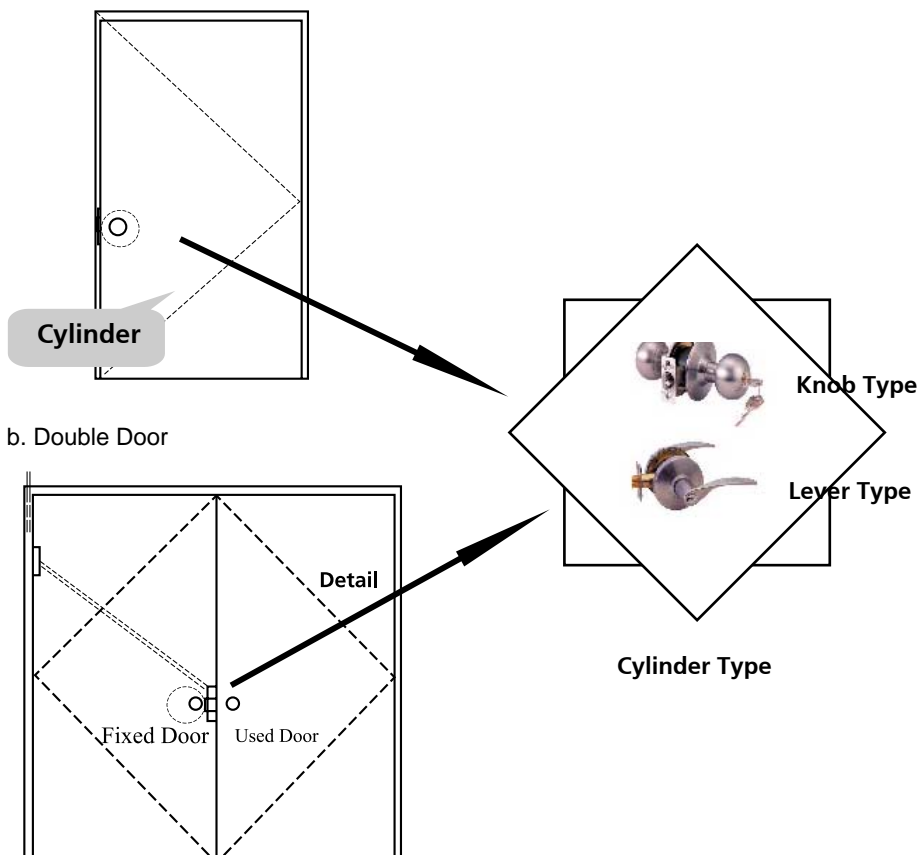

## 7-7. The Installation of Exit Button

- In case of using the button for exit inside the door.
- Decide whether install or not as the type of Lock.
- Case that exit button needs : On cutting latch of Cylinder & Lever  
On installation of Electro Magnetic Lock & Deadbolt
- Case that exit button doesn't need : On installation of Cylinder & Lever

### 7-7-1. Installation

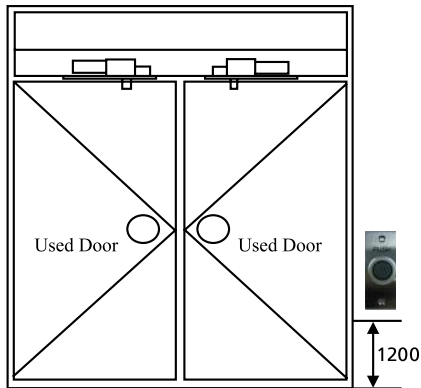

### 7-7-2. How to connect lines

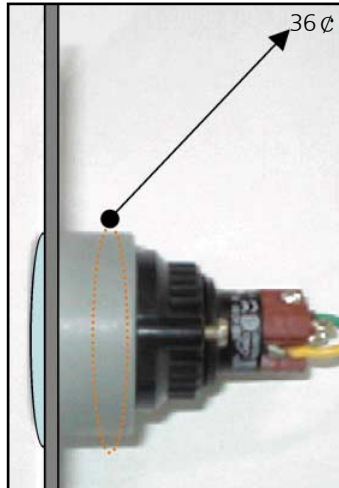

Connect at the  
input of Exit button

# Chapter 8

## **POWER PACK CONNECTION**

# Chapter 9

## TROUBLE SHOOTING

## 9-1. Ness 505R

### System operates abnormal

(Cause)	Of that user mistake, memory (SRAM) is damaged, or the system is defective of the device.
(Solution)	<p>1. Check BAT connection S/W (place template hole of reverse side) You have to push up the S/W, and system initialize before system installation.</p> <div style="display: flex; justify-content: space-around; align-items: center;"> <div style="border: 1px solid black; padding: 5px; text-align: center;"> <p>SETTING A DIP SWITCH</p> <p>Before                      After</p> </div> <div style="text-align: center;"> <p>ON</p> <p>ON</p> </div> </div> <p style="text-align: center;">Figure : DIP SWITCH SETTING</p> <div style="display: flex; justify-content: center; align-items: center;"> </div> <p style="text-align: center;">Figure : DIP SWITCH LOCATION</p> <p>2. If the trouble remains after checking the above, contact a designated service center.</p>

### Broken or abnormal letters show on the LCD, when powered on.

(Cause)	SRAM backup battery problem or LCD module problem.
(Solution)	<p>1. Initialize the controller</p> <ul style="list-style-type: none"> <li>- Connect the cyan wire, pink wire and black wire together</li> <li>- Power on the unit.</li> <li>- Enter key &lt;1&gt;</li> <li>- Check if the LCD shows message of "Initialize END" "turn off Power..."</li> <li>- Main power OFF</li> <li>- Separate 3 wire (pink, cyan and black (GND))</li> <li>- Main power ON again.</li> </ul> <p>* Aware that all the setting value will be back to the default value and all data memory be clear. (ID data clear / Event data clear / Time Schedule data clear etc.)</p> <p>2. Setup the data and time on SETUP MENU F1-&gt; SYS INITIALIZE and SETUP MENU F1-&gt; TIME SETTING.</p> <p>3. If you have problem, please contact a designated service center.</p>

### In case that Door Closed CONTACT MASTER message is shown and buzzer sound is heard when system is installed and card is present.

(Cause)	Setup Error, P/W Delete, System Demagnetization Defect
(Solution)	<p>1. Check whether yellow LED is turned on at the ordinary times. If so, it is the case door is closed by output T/S or the case of demagnetization defect.</p> <p>2. In case of No.1, check output T/S or initialize the device. If it is demagnetization defect, contact service center.</p> <p>3. In case that even the yellow LED is turned off, this means stored P/W is deleted. In this case, contact service center.</p>

### ACCESS DOOR ERR message is shown when card is presented at the door.

(Cause)	Setup Error, System Demagnetization Defect.
(Solution)	<p>1. Check ID information. In case that RD(Door State) is 0 in ID information, it means card is read at both system main board and exit reader. In case of 1, it means card is read at Exit Reader, and in case of 2, it means card is read at main device. If the number is 3, it is not appeared either main device or exit reader. If you want to modify, same card has to be registered again.</p> <p>2. If it is not the case of No.1, it is the case of demagnetization defect. Contact service center.</p>

## Doesn't enter the Setup Mode after entering the Master ID "00000000".

(Cause)	The Master ID might be changed or components are defective.
(Solution)	<ol style="list-style-type: none"> <li>1. Try changing the Master ID through the application SW.(It'll be changed to "00000000".) <ul style="list-style-type: none"> <li>- Note that the Master ID for iTDC-SR is 10 times &lt;0&gt;, "0000000000".</li> </ul> </li> <li>2. When it is not feasible, initialize the unit as followings. <ul style="list-style-type: none"> <li>- Press the two System Initialization Switches simultaneously while power is on.</li> <li>- Wait until the message 'Initialize END Turn OFF Power...' appears on the LCD and turn it off and on again. Try entering the Setup mode.</li> <li>- Note that all the value will be set to default, including the IDs after initializing.</li> </ul> </li> <li>3. If the trouble remains after the procedure above, contact a designated service center.</li> </ol>

## Forgetting the ID number after the change of Master ID

(Cause)	System Demagnetization Defect, Master number change, setup error..
(Solution)	<ol style="list-style-type: none"> <li>1. If PC SW is used, change and use new master ID by reference of SW manual.</li> <li>2. If PC SW is not used, initialize H/W by reference of H/W manual. In this case, all stored data will be deleted.</li> </ol>

## In case of using RF Card, it is normal, but in case of press the card number, it is abnormal.

(Cause)	Setting up error, demagnetization error.
(Solution)	<ol style="list-style-type: none"> <li>1. Check whether buzzer sound is heard, when keypad is pressed. In case of buzzer sound, it is the case that "RF_PIN_ENABLE" in Setting up Modes is set up as "DISABLE". Enter the Setting up Mode by using Master Card and set up as "ENABLE".</li> <li>2. If buzzer sound is not heard, contact service center.</li> </ol>

## Selecting and using "RF only" Mode or "RF + PW" Mode as user' ID card.

(Cause)	
(Solution)	<ol style="list-style-type: none"> <li>1. It is impossible. Mode Setup is applied equally at all cards registered in this device. For example, if you set up 'RF only' mode, door will be opened whenever registered card is just present. <b>Refer to Chapter 10 in page 48.</b></li> </ol>

## Randomly changed value of in/out define from previously setting value after power reset.

(Cause)	Discharge of RAM Back-Up battery problem during the main power off.
(Solution)	<ol style="list-style-type: none"> <li>1. Check if the Back-Up Battery Jumper is shorted.</li> <li>2. Check if the voltage of Back-Up Battery is over 3.6V.</li> <li>3. If it is over 3.6V, make initialization process as below. <ul style="list-style-type: none"> <li>- Connect the cyan wire, pink wire and black wire together</li> <li>- Power on the unit.</li> <li>- Enter key &lt;1&gt;.</li> <li>- Check if the LCD shows message of "Initialize END" "turn off Power...".</li> <li>- Main power OFF</li> <li>- Separate 3 wire(pink, cyan and black(GND))</li> <li>- Main power ON again.</li> </ul> <p>* Aware that all the setting value be back to the default value and data memory be clear. (ID data clear/Event data clear/ Time Schedule data clear etc.)</p> </li> <li>4. Define IN/OUTPUT value as intend and keep the main power on more than 5 days.</li> <li>5. If after all the above, the problem remains, please contact a designated service center.</li> </ol>

**A valid card became unregistered after batch-downloading IDs from PC.**

(Cause)	Wrong procedure during download, or a component defect.
(Solution)	<ol style="list-style-type: none"> <li>1. The card ID might be registered only to the controller and not registered in PC. The process of downloading IDs, 505R first erase the ID memory of the unit, therefore if the IDs from the PC didn't contain the card ID, this can happen.</li> <li>2. Check whether the card ID is registered in PC</li> <li>3. If not, please register the number and try downloading again.</li> <li>4. If the trouble remains after the procedure above, contact a designated service center.</li> </ol>

**In the process of setting the function at the Setting Mode, getting out into normal mode.**

(Cause)	
(Solution)	<ol style="list-style-type: none"> <li>1. It is normal. Device is programmed that if key is not pressed within 20 seconds, it is gotten out into normal mode automatically.</li> </ol>

**Card can be read at Exit Reader, but card data is not shown at main system or other data is shown.**

(Cause)	Reader deflection, line connection error between reader and system, demagnetization deflection, communication error by surrounding noise.
(Solution)	<ol style="list-style-type: none"> <li>1. Check reader deflection.(separate reader from system and estimate output node by Osilloscope.</li> <li>2. Check the line connection between reader and system, if it is not reader defect. Wiegand communication line and GND have to be connected. (Power can be used separately, but GND has to be used with system)</li> <li>3. If the same state is continued, contact service center.</li> </ol>

**“Beep~” sound is heard continuously, without any action**

(Cause)	Installation error, Tamper SW operation, demagnetization defect.
(Solution)	<ol style="list-style-type: none"> <li>1. In case that sensor is not attached at the input port, it is alarm by Tamper SW attached in the device.</li> <li>2. In case that the wall installed is not smooth.</li> <li>3. Set up output in F2 -&gt;“IN/OUT DEFINE”-&gt;TAMPER SW as “0”.</li> <li>4. If it is not the problem of Tamper SW, contact service center.</li> </ol>

**The Setup mode suddenly goes back to the Normal operating mode.**

(Cause)	Time out error
(Solution)	<ol style="list-style-type: none"> <li>1. In the Setup mode, it is programmed to do so when there is no key-in or reading card within 60 seconds.</li> </ol>

**The reader seems to read cards, but the controller does not respond or does not respond properly, such as displaying wrong card numbers in the reader test mode.**

(Cause)	Reader defect, wiring error between the reader and the controller, or the electric noises around.
(Solution)	<ol style="list-style-type: none"> <li>1. Be sure that the reader reads the card ID when you present a card.</li> <li>2. Be sure that the reader format is correct. 26bit Wiegand or 34bit Wiegand for SR505</li> <li>3. Check the wiring between the reader and 505R. <ul style="list-style-type: none"> <li>- Check the wires of Wiegand data lines D0 and D1 which is connected correctly.</li> <li>- Connect the controller ground to the ground wire of the reader and it is recommended to connect them to an earth ground.</li> </ul> </li> <li>4. Using oscilloscope, check the shape of signals from the reader at the controller's side. When noises are shown on the signals, it is recommended to use shielded wires and the unused wires to the common ground. You can use repeaters, also.</li> <li>5. Check the maximum cable length, which may be indicated on the reader manual.</li> <li>6. If the trouble remains after the procedure above, contact a designated service center.</li> </ol>

## Unable to communicate with PC after installation of device

(Cause)	Cable defect, Cable connection defect, address setting up error, communication port error, demagnetization defect
(Solution)	<ol style="list-style-type: none"> <li>1. Check cable and connection of cable(RS232, RS422).</li> <li>2. Check whether address set up at S/W is same with address set up at system. If they are different, modify the address.(refer to manual).</li> <li>3. If it is possible to estimate communication wave(by using Oscilloscope), estimate TX of PC (RX+/RX- of system) and check whether the signal goes out from PC, if signal doesn't go out, check communication port.</li> <li>4. In case of RS422 communication, hang end-node resistance at connection part between system and RS422/232 converter. (120 ohm between RX+ and RX- node of device, 120 ohm between TX+ and TX- node, the part of converter is same. If you don't know how to connect line, contact service center.</li> <li>5. If the problem is continued, contact service center.</li> </ol>

## SCHEDULE ERROR message shows when RFID card is read.

(Cause)	Error in RFID card registration, time schedule setting or the system itself.
(Solution)	<ol style="list-style-type: none"> <li>1. If it is of properly operating unit before, there has been electric shock that damaged internal memory and data. Please initialize the unit as instructed in the manual.</li> <li>2. Check if ID information is put incorrectly during its registration. * Register ID again checking the following points. -In order to restrict access of the ID user for specific time zone as instructed in the manual, register time schedule in advance and apply the time schedule code(1~10) in the registration of the user ID. - In order to allow the user to access at all times put "00".</li> <li>3. Use software for time schedule setting in case it is connected to PC as the software manual.</li> <li>4. If the trouble remains after checking the above, contact a designated service center.</li> </ol>

## Connection a lot of devices to a PC

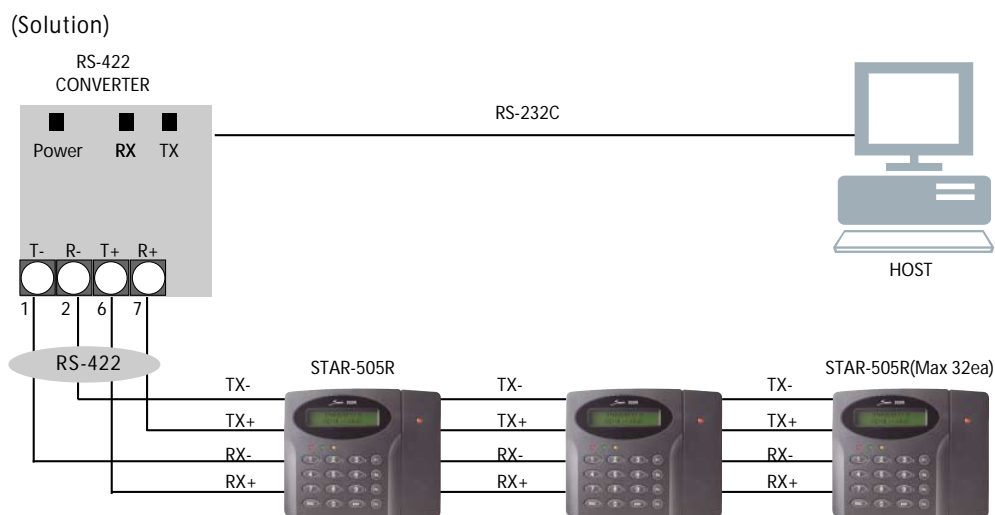

## 9-2. Ness FINGER007

Broken or abnormal letters show on LCD, when the power on.

(Cause)	Of troubles of its battery in charge of the internal back-up or of circuits near around
(Solution)	<ol style="list-style-type: none"> <li>1. Initialize the controller referring "hardware initialization of the manual"</li> <li>2. Set the current time in Set-Up menu of F1 and turn its power off and on again.</li> <li>3. If the problem remains after performing 1, 2 of the above, please contact IDTECK service center.</li> </ol>

Unable to enter set-up mode with MASTER ID (default value:'00000000'+ 'ENT') and P/W (default value: '3141'+ 'ENT')

(Cause)	Of internal element error, of unconsciously changed Master ID or of Set-up error
(Solution)	<ol style="list-style-type: none"> <li>1. Initialize the controller referring "hardware initialization of the manual" (If occurred before installation)</li> <li>2. Check MASTER ID and P/W and set RF_PIN_ENABLE option in ENABLE" via system setting in S/W.</li> <li>3. If the problem remains after performing 1, 2 of the above, please contact IDTECK service center.</li> </ol>

Unable to initiate the communication between the device and PC.

(Cause)	Of cable, cable connection error, communication address set up error, communication port error or internal element error.
(Solution)	<ol style="list-style-type: none"> <li>1. Check cable, cable connection(RS232, RS422)</li> <li>2. Check the accordance of communication address between in the device and in the S/W. If discord, modify one of the comm. address of the device or of the S/W discord to be accord. (Refer the manual)</li> <li>3. If able to measure the wave shape (by Oscilloscope or other measuring instruments), gauge the TX section of PC(RX+/RX- section of the device), check if the signal comes out from the PC. If not, please check the communication port.</li> <li>4. In case of RS422 communication, connect additionally a terminating resistance at the points of connection from the device (RS422) to RS232 converter and of from the PC (RS232) to RS232 converter. (120 ohm between RX+ and RX- section of the device, 120 ohm between TX+ and TX- section, same for the converter. If needed connection information, contact IDTECK A/S center.)</li> <li>5. If the problem remains after performing 1, 2, 3, 4 of the above, please contact IDTECK service center</li> </ol>

Unable to initiate the communication between the device and PC.

(Cause)	Of reader error, connection error of reader and the main device (FINGER007), internal elements error of the device or communication error of noise.
(Solution)	<ol style="list-style-type: none"> <li>1. Check if it is of reader defect.(separate the reader and measure its output terminal with oscilloscope or other measure)</li> <li>2. If not of reader defect, check the connection from the reader to controller. Communication line and GND should be connected. (Power may be of separated ones but GND must be connected to the one of the device together.)</li> <li>3. Connect the reader and the main device, measure the wiegand communication line of the main device with oscilloscope. If it shows output signal of reader but with serious noise, use repeater or use cable shield line and left lines as GND.</li> </ol>

Unable to register ID in the device that RF CARD and PIN ID mode both are in use.

(Cause)	Of the case that the ID is already registered, the ID is not proper format or internal elements have errors
(Solution)	<ol style="list-style-type: none"> <li>1. In Finger007 V4.0 or lower version, it accepts RF CARD and PIN (4 digit) registration. However, it is unable to register if the last 5 digit number among the 8digits card number are same with 4 digit PIN number. For example, card number is"XXXX0AAAA"and PIN ID ,"AAAA". Also Pin number"0000" is not acceptable.</li> <li>2. Finger007 V4.5 or higher version, all are acceptable except repeated card number.</li> <li>3. If the problem remains after checking 1, 2 of the above, please contact IDTECK service center</li> </ol>

### No operation after input of card number via keypad but proper operation after input of card number via RF CARD

(Cause)	Of set up error or internal element defect
(Solution)	<ol style="list-style-type: none"> <li>1. Check buzzer sound as key pad pressed. If it makes buzzer sound, "RF_PIN_ENABLE" is set improperly as "DISABLE". Get into set-up mode using master card, set it "ENABLE".</li> <li>2. If it does not make buzzer sound, its internal element defect is susceptible. Please contact IDTECK service center.</li> </ol>

### "Fingerprint error" shows in the LCD repeatedly during fingerprint registration.

(Cause)	Of that fingerprint is damaged, fingerprint is extremely dried or the fingerprint module is defective of the device.
(Solution)	<ol style="list-style-type: none"> <li>1. Of fingerprint registration, it read a fingerprint twice. If the first one and the second one are perfectly accord, its registration fails. After the first fingerprint reading, take the finger out and put again on the fingerprint reading window.</li> <li>2. If the fingerprint is extremely dry or seriously damaged, it can not find its specifications. Of version 4.0 or over, get into the setting mode, F1, TYPE SELECTION and change ADAPTIVE MODE "USE" and then try again its fingerprint registration. (ADAPTIVE MODE "USE" provides more delicate reading of fingerprint but it delays a little more than normal.)</li> <li>3. If the problem remains after performing 1, 2 of the above, it could be of fingerprint module defect or the device defect, please contact IDTECK service center</li> </ol>

### "Door Closed" & CONTACT MASTER" it shows on LCD with buzzer sounds after card reading.

(Cause)	Of setting error, PW deletion, defect of internal elements
(Solution)	<ol style="list-style-type: none"> <li>1. Check the communication status. If the communication of the device with PC is normal and this problem occurs, check if the yellow LED is on in normal. If normally the yellow LED is ON, the door is locked by output time schedule setting.</li> <li>2. If it is case of "1" check OUTPUT T/S or reinitialize the device. If the problem remains after performing it, please contact IDTECK service center.</li> <li>3. If it is not the case of "1", no communication, its yellow LED light off, it is of saved PW deletion. Please contact IDTECK service center.</li> <li>4. Of V4.5 or higher, in case of "3" it shows message "CONTACT IDTECK"WWW.IDTECK.COM with buzzer sound when the power is turn on.</li> </ol>

### 9-3. Ness - IDTEck iCON100

#### System operates abnormal.

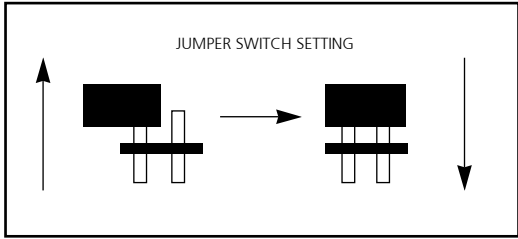
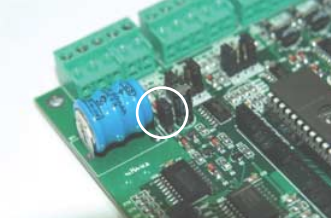
(Cause)	Of that user mistake, memory(SRAM) is damaged, or the system is defective of the device.
(Solution)	<p>1. Check BAT connection S/W. You have to connect the S/W, and system initialize before system installation.</p> <div style="display: flex; justify-content: space-around; align-items: center;"> <div style="border: 1px solid black; padding: 5px; text-align: center;"> <p>JUMPER SWITCH SETTING</p>  </div> <div style="text-align: center;">  </div> </div> <p style="text-align: center;">Figure: JUMPER SETTING <span style="margin-left: 100px;">Figure: Jumper location</span></p> <p>2. If the trouble remains after checking the above, contact a designated service center.</p>

#### Odd characters or something is displayed on LCD, when power is on.

(Cause)	Caused by the problem of back-up battery or sub-circuit in the product.
(Solution)	<p>1. Initialize H/W by reference manual.</p> <p>2. Turn off and turn on system power after set up the present time at the setup menu.</p> <p>3. If setting time is incorrect or odd letters are shown, it is the problem of sub-circuits. Contact the service center.</p>

#### No response, when card is presented.

(Cause)	<p>1. In case that IDTECK appointment number is not registered.</p> <p>2. In case that line connection of reader is incorrect.</p> <p>3. In case of reader inferiority.</p>
(Solution)	<p>1. When card is presented to the reader at Master Mode('00000000' + 'ENT')(Reader Test of Setup Mode 4, if card number is shown on LCD, it is the case that IDTECK appointment number is not registered at Reader. Contact the head office.</p> <p>2. In case that card number is not shown even at Master Mode.</p> <ul style="list-style-type: none"> <li>- Check whether card is read at the reader. (If card is read at the reader, the color of reader LED is changed. (RED-&gt;GREEN-&gt;RED))</li> <li>- Check whether line connection between reader and controller is correct, in case that card can be read at reader, but controller is not reacted. Connect D0 line of reader to D0 terminal of controller. Connect D1 line of reader to D1 terminal of controller.</li> <li>- In case that card is not read at reader. Check whether reader type(Motorola, IDC) is in accord with card type (Motorola, IDC)</li> </ul>

#### “ACCESS DOOR ERR” message is shown and door is still close, in spite that registered card is presented.

(Cause)	1. In case that card is not registered or registered ID information is incorrect.
(Solution)	<p>1. Check registered card information at Setup Mode 3 (ID LIST). Check the number written at the next line of RD. If the number is “0”, “ACCESS DOOR ERR” message is shown because card is already registered, but door open authorization by reading card is not given.</p> <p>2. In case that readers are installed at Entrance/Exit (If the number written at the next line of RD is “1” just permit for Entrance Reader, “2” just permit for Exit Reader and “3” permit for Entrance/Exit Readers)</p>

#### Unable to enter the Setup Mode, in spite of pressing the Master ID “00000000”.

(Cause)	<p>1. Device defection or the problem happened in the process of product test before installation.</p> <p>2. In case that Master ID number is incorrect.</p>
(Solution)	<p>1. Turn Off On No.8 dip switch at the state of Power-on. All data will be initialized and has to be set up again.</p> <p>2. “Turn OFF DIP8” “Press Any Key...” message on LCD is shown. Press “ESC” key and initialization is finished and you can enter the Setup Mode.(Master“00000000”)</p>

### Lost Master ID

(Cause)	Lost master ID
(Solution)	1. Initialize the device. (All stored data will be lost)

The reader seems to read cards, but the controller does not respond or does not respond properly, such as displaying wrong card numbers in the reader test mode.

(Cause)	Reader defect, wiring error between the reader and the controller, or the electric noises around.
(Solution)	<ol style="list-style-type: none"> <li>1. Be sure that the reader reads the card ID when you present a card.</li> <li>2. Be sure that the reader format is correct. 26bit Wiegand or 34bit Wiegand for iCON100SR</li> <li>3. Check the wiring between the reader and iCON100. <ul style="list-style-type: none"> <li>- Check the wires of Wiegand data lines D0 and D1 which is connected correctly.</li> <li>- Connect the controller ground to the ground wire of the reader and it is recommended to connect them to an earth ground.</li> </ul> </li> <li>4. Using oscilloscope, check the shape of signals from the reader at the controller's side. When noises are shown on the signals, it is recommended to use shielded wires and the unused wires to the common ground. You can use repeaters, also.</li> <li>5. Check the maximum cable length, which may be indicated on the reader manual.</li> <li>6. If the trouble remains after the procedure above, contact a designated service center.</li> </ol>

Keep making buzzer sound: "beep~ beep ~ beep" or "beep~~~~".

(Cause)	Error in installation, door status or internal circuits.
(Solution)	<ol style="list-style-type: none"> <li>1. Check the door status. It occurs in case that the door is opened over 20 sec after the proper door open time.</li> <li>2. Check the door contact sensor type: it should be NO type.</li> <li>3. Check in [IN/OUT DEFINE] of F2, the fifth Time schedule code(01~10) value of 15 output T/S. If the time schedule code is set between 01-10 and if the present time is included in the schedule. <ul style="list-style-type: none"> <li>If it is set to unintended value, change it to "00" ( Programmable via PC software)</li> </ul> </li> <li>4. If the trouble remains after checking the above, contact a designated service center.</li> </ol>

"SCHEDULE ERROR" message shows when RFID card is read.

(Cause)	Error in RFID card registration, time schedule setting or the system itself.
(Solution)	<ol style="list-style-type: none"> <li>1. If it is of properly operating unit before, there has been electric shock that damaged internal memory and data. Please initialize the unit as instructed in the manual.</li> <li>2. Check if ID information is put incorrectly during its registration. <ul style="list-style-type: none"> <li>* Register ID again checking the following points. <ul style="list-style-type: none"> <li>- In order to restrict access of the ID user for specific time zone as instructed in the manual, register time schedule in advance and apply the time schedule code(1~10) in the registration of the user ID.</li> <li>- In order to allow the user to access at all times put "00".</li> </ul> </li> </ul> </li> <li>3. Use software for time schedule setting in case it is connected to PC as the software manual.</li> <li>4. If the trouble remains after checking the above, contact a designated service center.</li> </ol>

Selecting and using "RF only" Mode or "RF + PW" Mode as user' ID card.

(Cause)	
(Solution)	<ol style="list-style-type: none"> <li>1. It is impossible. Mode Setup is applied equally at all cards registered in this device. For example, if you set up 'RF only' mode, door will be opened whenever registered card is just present. (If the number written at the next line of RD is "1" just permit for Entrance Reader, "2" just permit for Exit Reader and "3" permit for Entrance/Exit Readers)</li> </ol>

Door is not opened with "Beep~" sound when card is present to reader.

(Cause)	1. Reader is connected to iCON100 incorrectly.
(Solution)	<ol style="list-style-type: none"> <li>1. Check whether reader "D0" and "D1" is connected with iCON100 "D0" and "D1" correctly.</li> <li>2. If they are connected correctly, contact service center.</li> </ol>

At the “RF + PW” mode of ICON100, door is opened without press password at IN reader and door is opened with press password at OUT reader.

(Cause)	1. Position of In/Out reader is converted.
(Solution)	1. At the “RF + PW” Mode, device is set up as that Reader 1 has to be input surely password and Reader 2 doesn't check password. In this case, entrance reader is connected with reader2 port and exit reader is connected with reader1 port. Convert the position of readers.

Randomly changed value of in/out define from previously setting value after power reset.

(Cause)	Discharge of RAM Back-Up battery problem during the main power off.
(Solution)	<ol style="list-style-type: none"> <li>1. Check if the Back-Up Battery Jumper is shorted.</li> <li>2. Check if the voltage of Back-Up Battery is over 3.6V.</li> <li>3. If it is over 3.6V, make initialization process as below. <ul style="list-style-type: none"> <li>- In power-on, put off -&gt;on the #8 DIP switch.</li> <li>- Check if the LCD shows message of “Turn OFF DIP.8” “Press Any Key...”.</li> <li>- Put back DIP switch 8 from ON to OFF.</li> <li>- Make power reset (off and on).</li> </ul> </li> </ol> <p>* Aware that all the setting value be back to the default value and data memory be clear. (ID data clear/Event data clear/ Time Schedule data clear etc.)</p>

In the process of setting the function at the Setting Mode, getting out into normal mode.

(Cause)	1. It is normal. Device is programmed that if key is not pressed within 20 seconds, it is gotten out into normal mode automatically.
(Solution)	

Unable to communicate with PC after installation of device.

(Cause)	<ol style="list-style-type: none"> <li>1. Setup of address is incorrect.</li> <li>2. Communication line connection is incorrect.</li> </ol>
(Solution)	<ol style="list-style-type: none"> <li>1. Correct device address setup and try again.</li> <li>2. Check communication line connection.</li> </ol>

Frequent occurrence of communication error at PC

(Cause)	1. Noise on the communication cable
(Solution)	<ol style="list-style-type: none"> <li>1. In case of using RS422 communication, end-node treatment of cable is one of solution. (Refer to below treatment method)</li> <li>2. If it is covered up by using communication only cable, effect by noise will be decreased.</li> </ol>

## 9-4. Ness - IDTeck iTDC

Broken or abnormal letters show on the LCD, when powered on.

(Cause)	SRAM backup battery problem or LCD module problem.
(Solution)	<ol style="list-style-type: none"> <li>1. Initialize the controller and setup the date and time on SETUP MENU F2-&gt;SYS INITIALIZE and SETUP MENU F2-&gt;TIME SETTING.</li> <li>2. If you still have problem, please contact a designated service center.</li> </ol>

Can I set the controller to operate in RF only mode for one card and in RF+P/W mode for another?

(Cause)	N/A
(Solution)	<ol style="list-style-type: none"> <li>1. Do not mix the working mode for one Reader.</li> <li>2. But you can set one reader to operate in RF only mode and another one in RF+P/W mode.</li> </ol>

The Setup mode suddenly goes back to the Normal operating mode.

(Cause)	Time out error
(Solution)	<ol style="list-style-type: none"> <li>1. In the Setup mode, it is programmed to do so when there is no key-in or reading card within 20 seconds.</li> </ol>

A valid card became unregistered after batch-downloading IDs from PC.

(Cause)	Wrong procedure during download, or a component defect.
(Solution)	<ol style="list-style-type: none"> <li>1. The card ID might be registered only to the controller and not registered in PC. The process of downloading IDs, iTDC first erase the ID memory of the unit, therefore if the IDs from the PC didn't contain the card ID, this can happen.</li> <li>2. Check whether the card ID is registered in PC</li> <li>3. If not, please register the number and try downloading again.</li> <li>4. If the trouble remains after the procedure above, contact a designated service center.</li> </ol>

Doesn't enter the Setup Mode after entering the Master ID "00000000".

(Cause)	The Master ID might be changed or components are defective.
(Solution)	<ol style="list-style-type: none"> <li>1. Try changing the Master ID through the application SW.(It'll be changed to "00000000".) <ul style="list-style-type: none"> <li>- Note that the Master ID for iTDC-SR is 10 times &lt;0&gt;, "0000000000".</li> </ul> </li> <li>2. When it is not feasible, initialize the unit as followings. <ul style="list-style-type: none"> <li>- Press the two System Initialization Switches simultaneously while power is on.</li> <li>- Wait until the message 'Initialize END Turn OFF Power...' appears on the LCD and turn it off and on again. Try entering the Setup mode.</li> <li>- Note that all the value will be set to default, including the IDs after initializing.</li> </ul> </li> <li>3. If the trouble remains after the procedure above, contact a designated service center</li> </ol>

No problem with accessing by cards, but cannot access with the PIN input.

(Cause)	An error in Setup or possible component defect.
(Solution)	<ol style="list-style-type: none"> <li>1. Check whether a beep sound is generated when you press a key. <ul style="list-style-type: none"> <li>When it is, the problem may be an error in setup. Proceed followings. <ul style="list-style-type: none"> <li>- Enter the Master ID("00000000" default) to enter the Setup mode. (Note that the Master ID for iTDC-SR is 10 times &lt;0&gt;, "0000000000".)</li> <li>- Press &lt;F1&gt; key.</li> <li>- 'READER 1 MODE' will appear on the LCD, then use the key &lt;6&gt; to choose 'READER1 KEY IN', 'READER2 KEY IN', 'READER3 KEY IN', or 'READER4 KEY IN' and select 'Enable' as wanted.</li> </ul> </li> </ul> </li> <li>2. When there is no beep sound or already enabled Key-in functions, contact a designated service center.</li> </ol>

The reader seems to read cards, but the controller does not respond or does not respond properly, such as displaying wrong card numbers in the reader test mode.

(Cause)	Reader defect, wiring error between the reader and the controller, or the electric noises around.
(Solution)	<ol style="list-style-type: none"> <li>1. Be sure that the reader reads the card ID when you present a card.</li> <li>2. Be sure that the reader format is correct. 26bit Wiegand or 34bit Wiegand for iTDC-SR</li> <li>3. Check the wiring between the reader and iTDC.                     <ul style="list-style-type: none"> <li>- Check the wires of Wiegand data lines D0 and D1 which is connected correctly.</li> <li>- Connect the controller ground to the ground wire of the reader and it is recommended to connect them to an earth ground.</li> </ul> </li> <li>4. Using oscilloscope, check the shape of signals from the reader at the controller's side. When noises are shown on the signals, it is recommended to use shielded wires and the unused wires to the common ground. You can use repeaters, also.</li> <li>5. Check the maximum cable length, which may be indicated on the reader manual.</li> <li>6. If the trouble remains after the procedure above, contact a designated service center.</li> </ol>

**System operates abnormal.**

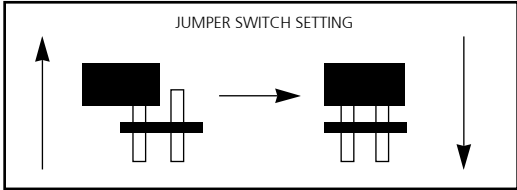
(Cause)	Of that user mistake, memory(SRAM) is damaged, or the system is defective of the device.
(Solution)	<ol style="list-style-type: none"> <li>1. Check BAT connection S/W. You have to connect the S/W, and system initialize before system installation.</li> </ol>  <p style="text-align: center;">Figure: JUMPER SETTING</p> <ol style="list-style-type: none"> <li>2. If the trouble remains after checking the above, contact a designated service center.</li> </ol>

**The controller does not communicate with PC.**

(Cause)	Defective cable is used, errors in wiring, an error in setting COMM ID of the controller, or damage on the communication port (either on PC side or on the controller side).																																																				
(Solution)	<ol style="list-style-type: none"> <li>1. Please, check the settings of the application S/W and the controller.             <ul style="list-style-type: none"> <li>- Check the controller's COMM ID is listed on the application S/W.</li> <li>- Set the different COMM ID when two or more controllers are installed.</li> <li>- Check the communication speed (9600bps default) is the same as the setting on the S/W.</li> <li>- Make sure that the PC's COM port is set correctly on the S/W.</li> <li>- The parameters at the S/W should be set as follows. Parity bit : NONE Data bit : 8bit Stop bit : 1bit</li> </ul> </li> <li>2. Check the line connection for communication.             <table border="1" style="width: 100%; border-collapse: collapse; text-align: center;"> <thead> <tr> <th colspan="2">RS232</th> <th colspan="3">RS422 (mono)</th> </tr> <tr> <th>iTDC</th> <th>PC</th> <th>iTDC</th> <th>RS422/232 Converter</th> <th>PC</th> </tr> </thead> <tbody> <tr> <td>TX port</td> <td>TX</td> <td>RX(-)</td> <td>TX(-)</td> <td rowspan="2">The RS232 cable from the converter</td> </tr> <tr> <td>RX port</td> <td>RX</td> <td>RX(+)</td> <td>TX(+)</td> </tr> <tr> <td>GND</td> <td>GND</td> <td>TX(-)</td> <td>RX(-)</td> <td></td> </tr> <tr> <td></td> <td></td> <td>TX(+)</td> <td>RX(+)</td> <td></td> </tr> </tbody> </table>   <table border="1" style="width: 100%; border-collapse: collapse; text-align: center;"> <thead> <tr> <th colspan="4">RS422(Multi Drop)</th> </tr> <tr> <th>iTDC</th> <th>iTDC</th> <th>RS422/232 Converter</th> <th>PC</th> </tr> </thead> <tbody> <tr> <td>RX(-)</td> <td>RX(-)</td> <td>TX(-)</td> <td rowspan="2">The RS232 cable from the converter</td> </tr> <tr> <td>RX(+)</td> <td>RX(+)</td> <td>TX(+)</td> </tr> <tr> <td>TX(-)</td> <td>TX(-)</td> <td>RX(-)</td> <td></td> </tr> <tr> <td>TX(+)</td> <td>TX(+)</td> <td>RX(+)</td> <td></td> </tr> </tbody> </table> </li> <li>3. In case of setting RS422 communication, recommend to use line-end resistors of 120 Ohm between the RX(+) and RX(-) lines and between the TX(+) and TX(-) lines, and apply the same resistors to the converter RS422 lines. Consult a service center or an electric technician if you cannot be sure how to do it.</li> <li>4. When a multi-drop communication doesn't work, test one-by-one communication first.</li> <li>5. If the trouble remains after the procedure above, contact a designated service center.</li> </ol>	RS232		RS422 (mono)			iTDC	PC	iTDC	RS422/232 Converter	PC	TX port	TX	RX(-)	TX(-)	The RS232 cable from the converter	RX port	RX	RX(+)	TX(+)	GND	GND	TX(-)	RX(-)				TX(+)	RX(+)		RS422(Multi Drop)				iTDC	iTDC	RS422/232 Converter	PC	RX(-)	RX(-)	TX(-)	The RS232 cable from the converter	RX(+)	RX(+)	TX(+)	TX(-)	TX(-)	RX(-)		TX(+)	TX(+)	RX(+)	
RS232		RS422 (mono)																																																			
iTDC	PC	iTDC	RS422/232 Converter	PC																																																	
TX port	TX	RX(-)	TX(-)	The RS232 cable from the converter																																																	
RX port	RX	RX(+)	TX(+)																																																		
GND	GND	TX(-)	RX(-)																																																		
		TX(+)	RX(+)																																																		
RS422(Multi Drop)																																																					
iTDC	iTDC	RS422/232 Converter	PC																																																		
RX(-)	RX(-)	TX(-)	The RS232 cable from the converter																																																		
RX(+)	RX(+)	TX(+)																																																			
TX(-)	TX(-)	RX(-)																																																			
TX(+)	TX(+)	RX(+)																																																			

## 9-6. Ness - IDTeck (PDL200) Q&A

### No response when card is presented

(Cause)	1. Unregistered card 2. Power is not supplied due to error on sensor
(Solution)	1. Register card if presented card is not registered device. 2. Approach card to infrared sensor closely.

### Door is not opened from inside of door

(Cause)	User did not push open button which located at door handle
(Solution)	Turn door handle while user is pushing open button.

### Red LED is on when card is presented (Door open status)

(Cause)	Device is in setup mode (Master card is presented )
(Solution)	1. Device is move to setup mode when master card is presented. 2. Present master card again and then LED will turn off. (Door close status) 3. Master card must not be presented for door access.

### Red LED keeps blinking

(Cause)	Object is placed nearby sensor
(Solution)	1. Make sure no object is place nearby sensor (within 15cm). 2. Make sure infrared sensor is clear and no dirty is on sensor 3. Remove any dirty and objects from device

### Green LED keeps blinking (Door Open S tatus)

(Cause)	Device is under manual-locking mode
(Solution)	1. If device is under manual-locking mode, device keeps opening the door when registered card is presented. Green LED keeps blinking to display door open status 2. Please study auto-locking mode and manual-locking mode from manual not to have any misunderstanding

### Unable to initialization with initialization button

(Cause)	Initialization button is pushed without power
(Solution)	1. Present hand or any object to infrared sensor. 2. Make sure red LED is blinking. 3. Push initialization button within 5 sec.

## 9-7. Software

### 1. General Check Points for Ness StarWatch Software series

#### Reporting S/W trouble to IDTECK Service center

(Solution)	<p>Please check trouble shooting before reporting. Enclose the following information when you report the trouble.</p> <ol style="list-style-type: none"> <li>1. Configuration of the system (number of controllers on a line, RS422 or TCP/IP)</li> <li>2. Version of software used</li> <li>3. Error message capture image</li> <li>4. Mast Mdb file copy</li> <li>5. PC system spec</li> </ol>
------------	--

#### PC Operating system support ( S/W installation trouble)

(Solution)	<p>STARWATCH PRO series are 32 bit Windows compatible S/W. It operates in Windows 98 SE, Windows 2000 Professional, Server Edition and higher versions, along with Windows XP Home and Professional. <b>It does NOT support Windows 95, 98, ME, or NT 4.0</b></p>
------------	---

#### Minimum PC configuration for less than 20 controllers

(Solution)	<p>One or two port usage is suitable. Maximum users of less than 100-200 users are recommended in configuration. Memory expansion improves system functions therefore, having more memory is beneficial.</p> <ol style="list-style-type: none"> <li>1. CPU: Pentium III-700 MHz or Higher</li> <li>2. Memory: 128 Mb or Higher</li> <li>3. HDD: 2 Gig min.</li> <li>4. Port: 2 serial port or Higher</li> <li>5. Network: 1 Ethernet card</li> <li>6. OS: Microsoft Windows 98 , Windows 2000 Professional or Windows XP Home</li> </ol>
------------	--

#### Recommended configuration for system of less than 60 controllers

(Solution)	<p>Four port usages are suitable. Maximum users of no more than 500 users recommended in configuration. In this case, it is good to have a separate PC to operate independently. It is recommended to use general PC mfrs and servers matching configurations below. Memory expansion improves system functions. Therefore having more memory is beneficial.</p> <ol style="list-style-type: none"> <li>1. CPU: Pentium 4 or Higher</li> <li>2. Memory: 256 Mb or Higher</li> <li>3. HDD: 4 Gig or Higher</li> <li>4. Port: 4 serial port (Needs Multi Port card) or Higher</li> <li>5. Network: 1 Ethernet card</li> <li>6. OS: Microsoft Windows 2000 Professional or Windows XP Professional</li> </ol>
------------	--

**Recommended configuration for system of over 60 controllers**

(Solution)	<p>8 ports or no less is suitable for operation. Maximum users of no less than 500 users recommended in configuration. In this case, it is good to have a separate PC to operate independently. It is recommended to use general PC mfrs and servers matching configurations below. Memory expansion improves system functions therefore, having more memory is beneficial.</p> <ol style="list-style-type: none"> <li>1. CPU: Pentium 4 or Dual processors.</li> <li>2. Memory: 512 Mb or Higher</li> <li>3. HDD: 8 Gig or Higher</li> <li>4. Port: 8 serial port (Needs Multi Port card) or Higher</li> <li>5. Network: 1 Ethernet card</li> <li>6. OS: Microsoft Windows 2000 server or Windows XP Professional</li> </ol>
------------	---

**Trouble reporting to IDTECK Service Center**

(Solution)	<p>Please check this trouble shooting before reporting. Enclose the following information to the report in detail to speed up the process.</p> <ol style="list-style-type: none"> <li>1. Error message capture image</li> <li>2. Configuration of the system</li> <li>3. Version of software used</li> <li>4. Mast Mdb file copy</li> <li>5. PC system spec</li> </ol>
------------	--

**"Comm Port Error" Message**

(Cause)	PC's serial (COM) port is already opened to another system or is out of work.
(Solution)	<ol style="list-style-type: none"> <li>1. Make sure the value of serial (COM) port set up in the S/W is accord with real COM port of PC.</li> <li>2. Press Ctrl+Alt+Del simultanously and check the processing list if the S/W is opened on the background. If it is opened, terminate the processing and re-start.</li> <li>3. In order to make sure the operation of PC 's serial port, perform loop test as following. Connect 2nd pin to 3rd pin of the port and start communication. If operates normally the port is out of problem.</li> <li>4. If the problem remains after performing 1, 2, 3 of the above, please contact IDTECK service center.</li> </ol>

**2. via RS232 communication error message (PC-Controller)**

**RX LED of controller is not blinking.**

(Cause)	S/W is not sending signal to the controller. Check PC and S/W side.								
(Solution)	<ol style="list-style-type: none"> <li>1. Check the communication environment of S/W. Check if the all the communication setting value is set as in the manual: COM port, Baud Rate (9600bps), Parity Bit, Stop Bit, Data Bit.</li> <li>2. Make sure that 9pin connector for PC serial port connection, is wired correctly to the controller line of (Rx, Tx GND).</li> </ol> <table border="1" style="width: 100%; border-collapse: collapse;"> <tr> <td style="width: 50%;">Controller Line</td> <td>PC 9 Pin Connector</td> </tr> <tr> <td>TXD</td> <td>Pin 2 (RXD)</td> </tr> <tr> <td>RXD</td> <td>Pin 3(TXD)</td> </tr> <tr> <td>GROUND</td> <td>Pin 5(GRD)</td> </tr> </table> <ol style="list-style-type: none"> <li>4. Make a loop test connecting 2nd pin to 3rd pin of the port and starting communication. If communication works, the port is out of problem. If communication works.</li> </ol>	Controller Line	PC 9 Pin Connector	TXD	Pin 2 (RXD)	RXD	Pin 3(TXD)	GROUND	Pin 5(GRD)
Controller Line	PC 9 Pin Connector								
TXD	Pin 2 (RXD)								
RXD	Pin 3(TXD)								
GROUND	Pin 5(GRD)								

**TX LED of controller is not blinking.**

(Cause)	Controller receives signal from S/W but it is not sending back to PC. Check the controller side.
(Solution)	<ol style="list-style-type: none"> <li>1. Check whether the board ID of in controller is accord with the board ID set in S/W.</li> <li>2. Make sure that 9pin connector for PC serial port connection, is wired correctly to the controller line of (Rx, Tx GND).</li> </ol>

**3. Via RS422 Communication trouble (PC-Converter-Controllers)****RX LED of CNP200 remains on but not blinking**

(Cause)	Electric noise on the communication line among the converter and
(Solution)	<ol style="list-style-type: none"> <li>1. Check the communication line and eliminate its noise.</li> <li>2. Refer to installation tips in page 100 and page 101 of this manual</li> </ol>

**TX LED of CNP200 converter is not blinking, it indicates that the S/W is not sending out signals. Check PC and S/W side.**

(Solution)	Refer the step one, a of RS232 Communication in the previous page.
------------	--

**RX LED of contoller is not blinking while the TX LED of CNP200 converter is blinking. It indicates that the converter is sending signal but the controller is not receiving.**

(Solution)	<ol style="list-style-type: none"> <li>1. Check the communication line among converter and controllers. <table border="1" data-bbox="375 891 1043 1041"> <tr> <td>Lines from controller Line</td> <td>9 Pin Connector of converter</td> </tr> <tr> <td>RX+</td> <td>Pin 6 (RED)</td> </tr> <tr> <td>RX-</td> <td>Pin 1(White)</td> </tr> <tr> <td>TX-</td> <td>Pin 2(Black)</td> </tr> <tr> <td>TX+</td> <td>Pin 7(Blue)</td> </tr> </table> </li> <li>6. Check the RS422 port of controller Initialize the controller</li> </ol>	Lines from controller Line	9 Pin Connector of converter	RX+	Pin 6 (RED)	RX-	Pin 1(White)	TX-	Pin 2(Black)	TX+	Pin 7(Blue)
Lines from controller Line	9 Pin Connector of converter										
RX+	Pin 6 (RED)										
RX-	Pin 1(White)										
TX-	Pin 2(Black)										
TX+	Pin 7(Blue)										

**RX LED of contoller is not blinking while the TX LED of CNP200 converter is blinking. It indicates that the converter is sending signal but the controller is not receiving.**

(Solution)	<ol style="list-style-type: none"> <li>1. Check communication line to converter.</li> <li>2. Check converter itself</li> <li>3. Check electric noise around communication line.</li> </ol>
------------	--

**RX LED of CNP200 converter is blinking but the data does not come into PC, it indicates that the PC is not receiving signal. Check PC and converter connection.**

(Solution)	<ol style="list-style-type: none"> <li>1. Check the 9pin connector betw. Converter and PC.</li> <li>2. Make a loop test of the PC com port.</li> </ol>
------------	--

**Only several controllers show communication trouble while the other controllers are communicating via the very same RS 422 line.**

(Solution)	<ol style="list-style-type: none"> <li>1. Check the communication line around those controllers in trouble.</li> <li>2. Check the converter and controller line connection.</li> <li>3. Check controller board ID.</li> <li>4. Initialize the controller.</li> </ol>
------------	--

**Only several controllers show communication trouble while the other controllers are communicating via the very same RS 422 line.**

(Solution)	<ol style="list-style-type: none"> <li>1. Check the communication line around those controllers in trouble.</li> <li>2. Check the converter and controller line connection.</li> <li>3. Check controller board ID.</li> <li>4. Initialize the controller.</li> </ol>
------------	--

#### 4. Via TCP/IP Communication

<b>Error message 'Can't Create Socket Error'</b>	
(Cause)	Unstable socket connection betw.TCP/IP Converter(Module) and PC
(Solution)	<ol style="list-style-type: none"> <li>1. Check Lan card of PC Lan Card to make sure the network connection of the PC.</li> <li>2. Perform ping test to check the connection from PC to the TCP/IP converter (Module).</li> <li>3. Check the IP address setting of the TCP/IP Converter(Module) in S/W.</li> <li>4. Check the TCP/IP Converter(Module) setting.</li> <li>5. Make sure the IP Address is one of the unique and recognized IP address of the network.</li> <li>6. Make sure that port no is 5000 Port.</li> <li>7. Make sure the Gateway IP Address is correct.</li> <li>8. Check if firewall is applied in the network. If yes, consult to network manager of the site and make sure the IP address band used is out of the firewall.</li> <li>9. Make sure the IP address of TCP/IP converter (Module) is not redundant.</li> <li>10. In case it is sure that all setting and connection are correctly done but still in trouble, consult with network manager of the site.</li> </ol>

<b>If the TCP/IP converter/module is not found in the TCP/IP converter setting program although the converter/module is connected to PC with correctness.</b>	
(Cause)	The TCP/IP TCP/IP Converter(Module)is not within the gateway of PC.
(Solution)	<ol style="list-style-type: none"> <li>1. Check Lan card of PC Lan Card to make sure the network connection of the PC.</li> <li>2. The TCP/IP converter/module must be within the gateway of the PC.</li> <li>3. If it is not possible to set it in network, use cross cable connecting one to one to make its setting.</li> </ol>

<b>Communication error in controller connected to TCP/IP Converter/Module</b>	
(Cause)	Defected controller or incorrect communication setting
(Solution)	<ol style="list-style-type: none"> <li>1. Check the controller.</li> <li>2. Check the board ID is accord to the ID set in the S/W.</li> <li>3. Check correctness of serial communication setting of TCP/IP Converter/Module :Baud Rate (9600bps), Parity Bit , Stop Bit, Data Bit.</li> <li>4. In case of use of external TCP/IP Converter check its DIP(Piano) Switch of RS232,RS422 is set correctly RS232 : DIP Switch 1 , 3 , 5 – Down 2 , 4 , 6 – Up RS422 : DIP Switch 1 , 3 , 5 – UP 2 , 4 , 6 - Down</li> <li>5. In case of use of external TCP/IP Converter check pin number of communication connector from controller to TCP/IP Converter(Module).</li> <li>6. Initialize the controller.</li> <li>7. If the problem remains after performing 1, 2 , 3, 4 ,5 of the above, please contact IDTECK service center</li> </ol>

<b>Properly running s/w got in to a trouble in a sudden. So it is turned off and turned on. However it is not communicating any more.</b>	
(Cause)	The connection betw. PC and TCP/IP Converter(Module) has not disconnected although it is not shown in screen. The S/W is still in the memory of the PC.
(Solution)	<ol style="list-style-type: none"> <li>1. Press Ctrl + Alt + Del and check if the S/W is in the operating system list . If yes, terminate the S/W on the background and reopen the S/W.</li> <li>2. Check if TCP/IP LED in external TCP/IP Converter(Module) is on. If yes, turn off and on then retry its connection. Check if the Expire Time value of the TC/IP converter setting S/W is 30~40.</li> <li>3. Check Lan card of PC의 Lan Card to make sure the network connection of the PC.</li> <li>4. If the problem remains after checking 1, 2 ,3 of the above, please contact IDTECK service center</li> </ol>

**Properly running s/w got in to a trouble in a sudden. So it is turned off and turned on. However it is not communicating any more.**

(Cause)	The connection betw. PC and TCP/IP Converter(Module) has not disconnected although it is not shown in screen. The S/W is still in the memory of the PC.
(Solution)	<ol style="list-style-type: none"> <li>1. Press Ctrl + Alt + Del and check if the S/W is in the operating system list . If yes, terminate the S/W on the background and reopen the S/W.</li> <li>2. Check if TCP/IP LED in external TCP/IP Converter(Module) is on. If yes, turn off and on then retry its connection. Check if the Expire Time value of the TC/IP converter setting S/W is 30~40.</li> <li>3. Check Lan card of PC의 Lan Card to make sure the network connection of the PC.</li> <li>4. If the problem remains after checking 1, 2 ,3 of the above, please contact IDTECK service center</li> </ol>

**The data from controller is broken.**

(Cause)	Controller memory is damaged or communication line has noise .
(Solution)	<ol style="list-style-type: none"> <li>1. Initialize the controller and restart the S/W.</li> <li>2. Check the line noise as in the manual.</li> <li>3. If the problem remains after checking 1, 2 of the above, please contact IDTECK service center</li> </ol>

**Normally working software gets disconnected often.**

(Cause)	Defect of TCP/IP Converter(Module) or unstable network.
(Solution)	<ol style="list-style-type: none"> <li>1. Replace TCP/IP Converter(Module)and retry.</li> <li>2. Check the network with network manager..</li> <li>3. If the problem remains after checking 1, 2 of the above, please contact IDTECK service center</li> </ol>

**Checking communication via TCP/IP Converter (Module)**

(Solution)	<p><b>General</b></p> <ul style="list-style-type: none"> <li>- Not able to connect TCP/IP Converter(Module).</li> </ul> <ol style="list-style-type: none"> <li>1. Check the connection of TCP/IP Converter(Module) to network.</li> <li>2. Check the network setting of TCP/IP Converter(Module).</li> <li>3. Check if firewall is applied in the network. If yes, consult to network manager of the site and make sure the IP address band used is out of the firewall.</li> <li>4. Make sure the IP address of TCP/IP converter (Module) is not redundant.</li> </ol> <p><b>External TCP/IP Converter(Module) via RS232 communication</b></p> <ul style="list-style-type: none"> <li>- RX LED of controller is not blinking that is connected to TCP/IP Converter(Module).</li> </ul> <ol style="list-style-type: none"> <li>1. S/W is not sending signal so check S/W and PC side.</li> <li>2. Check correctness of serial communication setting of TCP/IP Converter/Module :Baud Rate (9600bps) , Parity Bit , Stop Bit, Data Bit.</li> <li>3. Check the serial port pin number of TCP/IP Converter(Module)</li> </ol> <table border="1" data-bbox="363 1518 1257 1637"> <tr> <td>Lines from controller Line</td> <td>9 Pin Connector of TCP/IP Converter(Module)</td> </tr> <tr> <td>RXD</td> <td>Pin 2</td> </tr> <tr> <td>RXD</td> <td>Pin 3</td> </tr> <tr> <td>GROUND</td> <td>Pin 5</td> </tr> </table> <ol style="list-style-type: none"> <li>4. Perform Loop test of TCP/IP converter serial port connecting pin2 and pin3.</li> <li>5. Make sure the DIP Switch of TCP/IP converter. <ol style="list-style-type: none"> <li>1. On(Down)</li> <li>2. Off(Up)</li> <li>3. On(Down)</li> <li>4. Off(Up)</li> <li>5. On(Down)</li> <li>6. Off(Up)</li> </ol> </li> </ol>	Lines from controller Line	9 Pin Connector of TCP/IP Converter(Module)	RXD	Pin 2	RXD	Pin 3	GROUND	Pin 5
Lines from controller Line	9 Pin Connector of TCP/IP Converter(Module)								
RXD	Pin 2								
RXD	Pin 3								
GROUND	Pin 5								

- TX LED of controller is not blinking.
  1. Controller is not sending signal. Check the controller side.
  2. Make sure the controller ID is accord to the ID set in S/W.
  3. Check the serial port pin number of TCP/IP Converter(Module)

Lines from controller Line	9 Pin Connector of TCP/IP Converter(Module)
RXD	Pin 2
RXD	Pin 3
GROUND	Pin 5

**External TCP/IP Converter(Module) via RS422**

- RX LED of Contoller is not blinking.
  1. TCP/IP Converter(Module) is sending signal but controller is not receiving the signal  
Check the connection betw.them.

Lines from controller Line	9 Pin Connector of TCP/IP Converter(Module)
RX+	Pin 3
RX-	Pin 8
TX-	Pin 7
TX+	Pin2

2. Check the RS422 port of the controller.
3. Make sure the DIP Switch of TCP/IP converter.
  - No. Switch
  - 1. Off(Up)
  - 2. On(Down)
  - 3. Off(Up)
  - 4. On(Down)
  - 5. Off(Up)
  - 6. On(Down)
- TX LED of the controller is blinking but data does not come in.
  1. The signal from converter is received in the converter but the converter is not sending the signal to PC. Check converter side..
  2. Check the TX communication line of TCP/IP converter.
  3. Replace TCP/IP converter to check the defect of the converter.
  4. Check the communication noise.
- RX LED of TCP/IP converter is blinking but data is not come in to PC..
  1. Converter is sending signal properly but PC is not able to receive it.
  2. Check Lan line connected from converter to PC.

**Only several controllers show communication trouble while the other controllers are communicating via the very same RS 422 line connected to a external TCP/IP converter.**

- (Solution)
1. Eliminate the communication line noise around those controllers in trouble.
  2. Check the converter and controller line connection.
  3. Check controller board ID.
  4. Initialize the controller.