



*Security Products*

# NESS-M1XSP

Lighting Interface, Thermostat Interface,  
and Serial Port Expander

# INSTALLATION MANUAL

*IMPORTANT NOTICE: Every effort has been made to assure the accuracy of the information contained in this document as of the date printed. The extent of integration between the Elk Products M1XSP and other products varies from product to product. Some integration is more powerful or feature rich than others. In some cases there are variables or limitations not within Elk's or Ness' control which may render certain desirable features unavailable or unusable. Certain manufacturer products and/or protocols, including Elk's may not contain the capabilities or data definitions to permit additional integration beyond what is currently available. In addition, manufacturers may add, modify, or discontinued features or support with little or no notification to others. For reasons stated, Ness Security Products makes no warranty that it will be able to integrate all available features or operations, nor does it make any express or implied warranties of fitness for a particular purpose or of merchantability. Refer Ness's Limited Warranty.*

# Table of Contents

<b>General Installation and Setup</b> .....	<b>3</b>
<b>Aprilaire 8870 Thermostat(s)</b> .....	<b>5</b>
<b>RCS TR16 (RS-232 Format) Thermostat(s)</b> .....	<b>6</b>
<b>RCS TR16/TR40 (RS-485 Format) Thermostats(s)</b> .....	<b>7</b>
<b>HAI RC Series (RS-232 Format) Thermostat(s)</b> .....	<b>8</b>
<b>Lighting Controllers with RS-232 "Serial" Interfaces</b> .....	<b>9</b>
OnQ-ALC - (Individual Lighting Switches) .....	10
UPB - (Individual Lighting Loads and Links) .....	11
Centralite LiteJet - (Individual Lighting Loads and Scenes) .....	12
Lutron RadioRA - (Phantoms, Zones, Security Flash/Solid, Master Ctrl Buttons) .....	14
<b>Clipsal C-Bus</b> .....	<b>17</b>
<b>Data Bus E.O.L. Termination - VERY IMPORTANT!</b> .....	<b>18</b>
<b>M1XSP Compatibility, Jumper Settings and Misc. Information</b> .....	<b>20</b>

## APPLICATION:

The **ELK-M1XSP** is a "3 in 1" product. As a lighting interface, it adapts the M1 Control to many brands of Lighting control products which use "serial" communications. i.e., OnQ-ALC, PCS-UPB, EDT, CENTRALITE, VANTAGE, C-Bus (VIA NESS C\_BUS INTERFACE), etc. As a thermostat interface, it adapts the M1 Control to HVAC Communicating Thermostats from companies such as: RCS, APRILAIRE, and HAI. As a serial port expander, it expands the RS-232 communication ports of the M1 for multiple connections to most any type of equipment that communicates using serial ASCII commands. i.e., Personal Computers and many types of equipment which feature an RS-232 communications connection. Jumpers on the M1XSP select the appropriate application, connection, and protocol. Best of all, the M1XSP operates from the 4-wire (RS-485) M1 Keypad data bus, allowing RS-232 ports to be located long distances from the control. The M1G (Gold) and M1EZ8 Cross Platform Controls support up to 7 M1XSPs while the M1 (Std) supports 1 M1XSP. The communications baud rate is adjustable from 300 to 38,400 baud. The unit comes complete with cable and a black surface mountable housing.

## FEATURES:

- Adapts the M1 and M1EZ8 to specific Lighting control products which use "serial" communications.
- Adapts the M1 and M1EZ8 to specific HVAC Communicating Thermostats from RCS, Aprilaire, and HAI
- Expands the M1 and M1EZ8 RS-232 Serial Ports
- Connect to and Operates from the RS485 Data Bus
- Address Settings via DIP Switches
- Jumper Options and LED Diagnostic indicator
- On-Board EOL Bus Termination Jumper
- Flash Memory for Firmware Updating

## SPECIFICATIONS:

- Maximum of Expandable Ports (Units): 7 with M1G or M1EZ8.
- Operating Voltage: 12 Volts D.C.
- Current Draw: 31mA
- Housing Dimensions: 111.13 mm x 76.3 mm x 28.58 mm (4.375" x 3.0" x 1.125")
- Circuit Board Dimensions: 88.90 mm x 69.85mm (3.5" x 2.75)

# General Installation and Setup

INSTALL UNIT \* SET ADDRESS AND OPTION JUMPERS \* ACTIVATE M1 BUS ENROLLMENT PROCESS

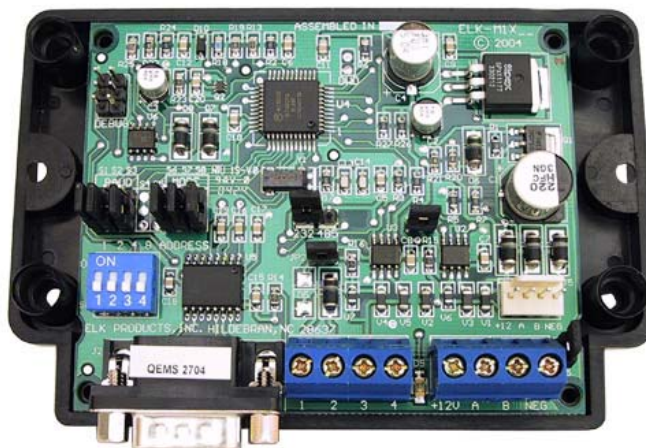

1. The M1XSP operates on the M1's Keypad data bus and may be remotely located near the equipment to which it is interfacing. Two (2) #6 x 1/2" screws (not provided), one on each side of the black box should be used. It can also be mounted inside the M1 cabinet using the same method OR by removing the board from the black box and installing the board into a pair of ELK-SWG Plastic Glide brackets.
2. Before making any wiring connections, turn Off the M1 Master Power Switch.
3. Connect terminals +12V, A, B, and Neg from the M1XSP to the M1's Keypad Data Bus (terminals +VKP, Data A, Data B, & Neg). **NOTE: Refer to the M1 Installation Manual and the M1DBH information in this manual about proper connections of data bus devices with multiple homerun cables.**
4. There are 4 address switches, each with a position of OFF or ON (binary value 0 or 1) and a decimal equivalent value of (1, 2, 4, or 8). The total decimal value of the "ON" switches equates to the data bus address. As a rule, the first M1XSP should be set to address 1. If more than 1 M1XSP is installed, set each one to a unique (sequential) address (2, 3, etc).

**Table 1: Data Bus Address Switches**

Data Bus Address	Switch Settings			
	S1	S2	S3	S4
1	On	Off	Off	Off
2	Off	On	Off	Off
3	On	On	Off	Off
4	Off	Off	On	Off
5	On	Off	On	Off
6	Off	On	On	Off
7	On	On	On	Off

Other Jumper Settings  
 JP1 Used to engage a 120 Ohm resistor for terminating the M1 RS-485 Data Bus.  
 See Data bus wiring instructions before use.

**IMPORTANT: When interfacing with HAI Thermostats, address switches on the M1XSP may ONLY be set to 1, 2, 3, or 4. Address 1 talks with HAI Thermostats addressed as 1 thru 4. Address 2 talks with HAI Thermostats addressed as 5 to 8. Address 3 talks with HAI Thermostats addressed as 9 to 12. Address 4 talks with HAI Thermostats addressed as 13 to 16.**

5. Set the Mode jumpers according to the desired application. Refer to the jumper settings table on page 10. If the M1XSP is being used for a Lighting or Thermostat application the baud rate will be internally fixed according to the mode/protocol. **The baud rate jumpers are ignored UNLESS it is jumpered to be a Serial Port Expander.**

**Steps 6 & 7 may be skipped when using the M1XSP as a Lighting or Thermostat interface.**

6. If the M1XSP is only being used as a serial port expander, it will necessary to set the BAUD Rate Jumpers to the desired speed. See page 10.
7. As a serial port expander, the M1XSP can be connected to a PC or other communication equipment using a standard 9 pin RS-232 serial cable. Distance for an RS-232 serial cable is 3.0 Mts (10 ft.) nominal, 15 Mts (50 ft.) maximum. Of course, since the M1XSP operates on the M1's 4-wire Keypad Data Bus, it can be located a great distance from the M1 and thereby closer to the other equipment so that the RS-232 length limits are not such an issue.
8. For use with Thermostats or Lighting Controllers, set the Format jumper (JP3) according to the type of communication format that the interfacing equipment requires. In 99% of the cases this jumper will probably be set to the "232" position. Refer to the the jumper settings on page 10.
9. For Thermostat and Lighting Controller hookups refer to the appropriate diagrams on the following pages.
10. After all connections are complete, turn On the M1 Master Power Switch.
11. Enroll the M1XSP into the M1 Control as follows: From the Keypad access the Installer level programming. Select Menu 01-Bus Module Enrollment. Press the right arrow key to start the enrollment. When the keypad indicates enrollment complete, press the right arrow key to view the results. Among the displayed enrolled devices there should be a type 5 (T5) device at address 01.

NOTE: If it becomes necessary to replace an already installed M1XSP, set the new unit to the same address as the old unit and repeat this enrollment process. If a device is permanently removed, the enrollment process must be performed in order to de-enroll the unit and thereby prevent a "missing" trouble condition.

**Diagnostic LED indication**

Slow blink (1/2 sec.) = Normal communication with M1.

Fast flicker = Communicating with other equipment (Thermostat, Lighting Controller, PC, etc.)

No blink = No communication with M1. Unit might be unplugged or powered off.

# Aprilaire 8870 Thermostat(s)

1. Install and wire the Aprilaire 8811 Protocol Adapter, 8818 Distribution Panel, and 8870 Thermostat using the instructions that come with the Aprilaire.
2. Install the NESS-M1XSP per the instructions on page 3. Be sure to enroll the device into the M1.
3. Set the MODE jumpers S5=1, S6=0, S7=1, & S8=1 for Aprilaire. If the M1XSP has a jumper S4, set it to =1. Set Jumper JP3 to the "232" position. The BAUD jumpers S1,S2, & S3 do not matter as the Aprilaire baud rate is preset internally.
4. Plug the Aprilaire supplied 6 ft RJ to DB9 Cable between the 8811 Protocol Adapter and the NESS-M1XSP. DO NOT USE THE Ness-WO37A CABLE.
5. Power up the Aprilaire Thermostat and Protocol Adapter.
6. Program the unit address and any other options in the Thermostat per its instructions. The unit address must match the Thermostat number in the M1 Control. The first Thermostat should be Address 1.
7. Using the NESS-RP Software, program the M1 using steps A,B, and C. Test and verify operation using steps D and E.
  - 7a. Click on the Automation Tab in the NESS-RP software. Click on Thermostat icon and program a name for Thermostat 1.
  - 7b. Click on the Task icon and program at least two tasks. Name the 1st Task "Economy Mode" and the 2nd "Comfort Mode".
  - 7c. Click on the Rules icon and create the following 4 rules.

Whenever [Area Name] Armed State Becomes Armed Away  
Then Activate [Economy Mode] (Task 1)

Whenever [Task Name] (Task 1) Is Activated  
Then Set [Thermostat 1] (TStat 1) Cooling Desired Temp to 30 degrees

Whenever [Area] Armed State Becomes Disarmed  
Then Activate [Comfort Mode] (Task 2)

Whenever [Task Name] (Task 2) Is Activated  
Then Set [Thermostat 1] (TStat 1) Cooling Desired Temp to 21 degrees

- 7d. Use the M1 Keypad to verify the M1XSP & Thermostat operation. Press the "ELK" key followed by the Right arrow key to access Menu 1-View/Control Automation Fncts. Press 6 for the Thermostat Temperature sub-menu, followed by Right arrow key. The Keypad should display the first Thermostat (T01) along with its name and current temperature reading.
- 7e. Go into the Tasks sub-menu and select Economy Mode (Task 1). Press the # key to activate. When this task is activated the thermostat cooling setpoint should go to 30 degrees. Confirm this on the display.

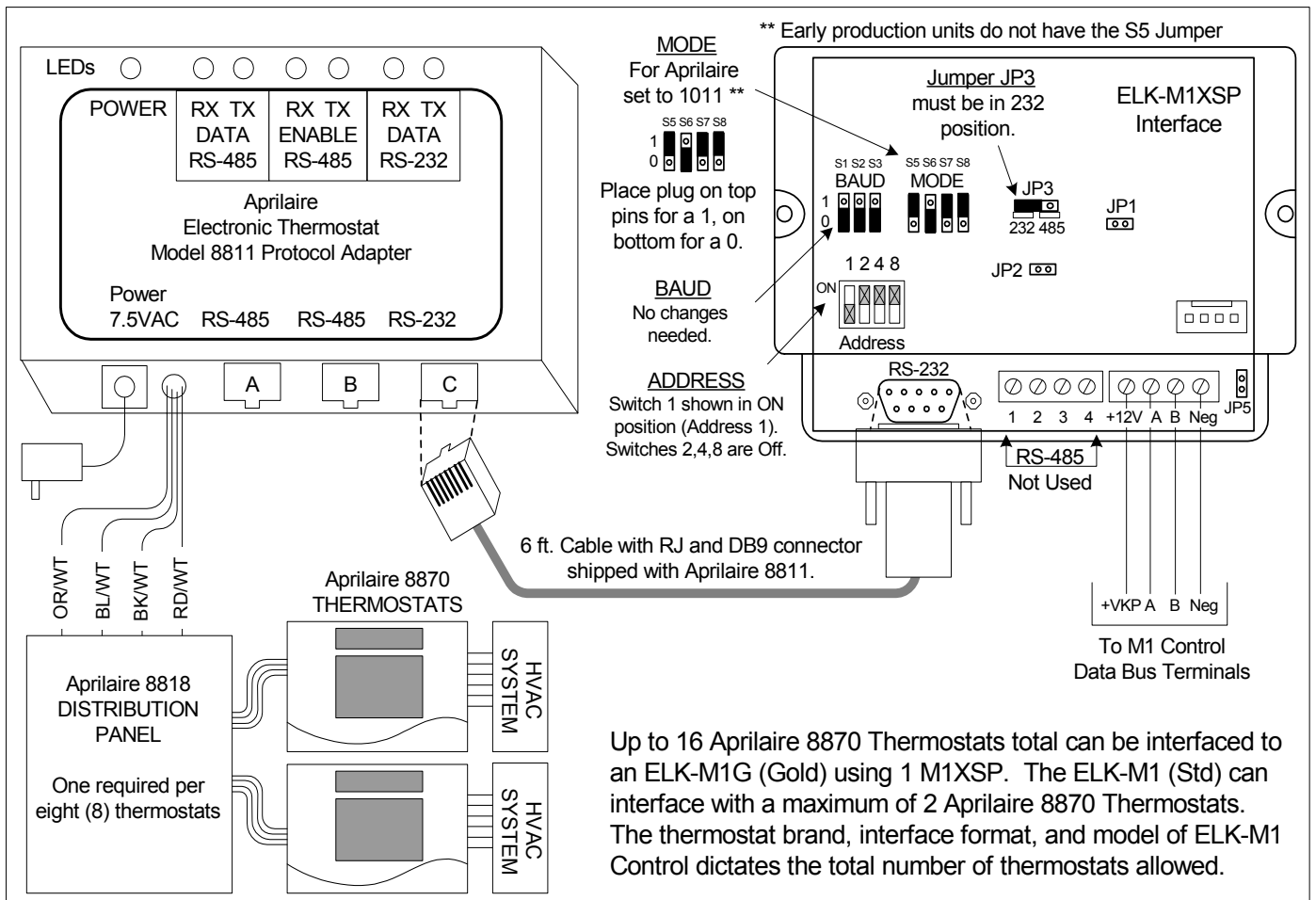

# RCS TR16 (RS-232 Format) Thermostat(s)

1. Install, and wire the RCS Control Unit and Wall Display Unit to the HVAC system per the RCS instructions.
2. Install the ELK-M1XSP per the instructions on page 3. Be sure to enroll the device into the M1.
3. Set the MODE jumpers S5=1, S6=0, S7=0, & S8=1 for RCS mode. If the M1XSP has jumper S4, set it to =1. Set Jumper JP3 to the "232" position. The BAUD jumpers S1,S2, & S3 do not matter as the RCS baud rate is preset internally.
4. Connect the Black, Red, and Green wires from the NESS-WO37A cable to the RS-232 terminals on the RCS Thermostat Control unit. The White (Yellow) wire is optional. It may be used to supply +12VDC from the M1XSP to the Thermostat in lieu of the HVAC power. Consult the RCS manual for details. Plug the other end of the NESS-WO37A cable into the 9 pin serial connector on the M1XSP.
5. Power up the RCS Thermostat Control Unit.
6. Program the Unit Address and any other options in the RCS Unit per its instructions. The unit address must match the Thermostat number in the M1 Control. The first Thermostat should be Address 1.
7. Using the NESS-RP Software, program the M1 using the following steps. Test and verify operation using steps d and e.
  - 7a. Click on the Automation Tab in the NESS-RP software. Click on Thermostat icon and program a name for Thermostat 1.
  - 7b. Click on the Task icon and program at least two tasks. Name the 1st Task "Economy Mode" and the 2nd "Comfort Mode".
  - 7c. Click on the Rules icon and create the following 4 rules.

Whenever [Area Name] Armed State Becomes Armed Away  
Then Activate [Economy Mode] (Task 1)

Whenever [Task Name] (Task 1) Is Activated  
Then Set [Thermostat 1] (TStat 1) Cooling Desired Temp to 30 degrees

Whenever [Area] Armed State Becomes Disarmed  
Then Activate [Comfort Mode] (Task 2)

Whenever [Task Name] (Task 2) Is Activated  
Then Set [Thermostat 1] (TStat 1) Cooling Desired Temp to 21 degrees

- 7d. Use the M1 Keypad to verify the M1XSP & Thermostat operation. Press the "ELK" key followed by the Right arrow key to access Menu 1-View/Control Automation Fncts. Press 6 for the Thermostat Temperature sub-menu, followed by Right arrow key. The Keypad should display the first Thermostat (T01) along with its name and current temperature reading.
- 7e. Go into the Tasks sub-menu and select Economy Mode (Task 1). Press the # key to activate. When this task is activated the thermostat cooling setpoint should go to 30 degrees. Confirm this on the Thermostat display.

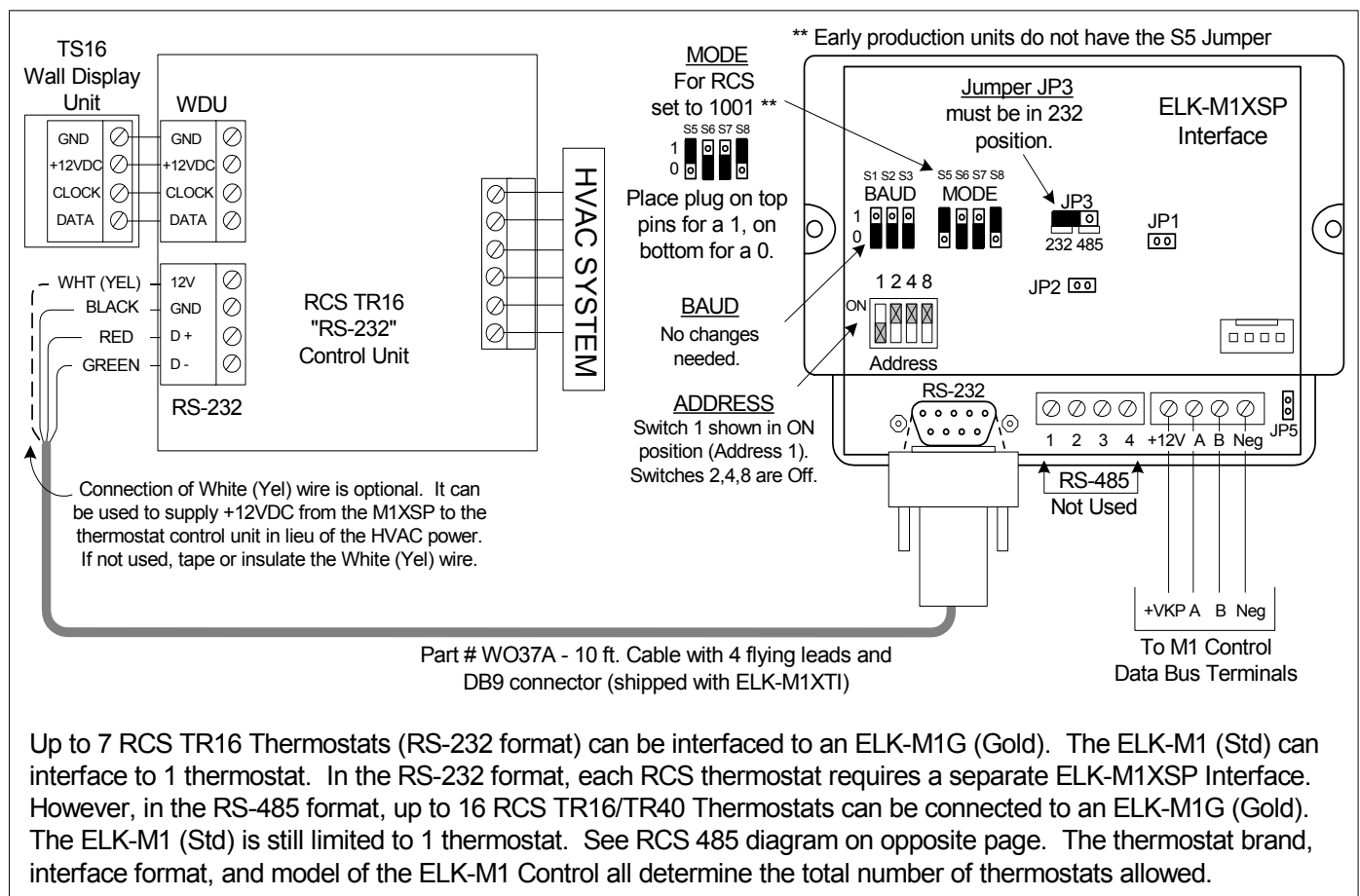

Up to 7 RCS TR16 Thermostats (RS-232 format) can be interfaced to an ELK-M1G (Gold). The ELK-M1 (Std) can interface to 1 thermostat. In the RS-232 format, each RCS thermostat requires a separate ELK-M1XSP Interface. However, in the RS-485 format, up to 16 RCS TR16/TR40 Thermostats can be connected to an ELK-M1G (Gold). The ELK-M1 (Std) is still limited to 1 thermostat. See RCS 485 diagram on opposite page. The thermostat brand, interface format, and model of the ELK-M1 Control all determine the total number of thermostats allowed.

# RCS TR16/TR40 (RS-485 Format) Thermostats(s)

1. Install, and wire the RCS Control Unit and Wall Display Unit to the HVAC system per the RCS instructions.
2. Install the ELK-M1XSP per the instructions on page 3. Be sure to enroll the device into the M1.
3. Set the MODE jumpers S5=1, S6=0, S7=0, & S8=1 for RCS mode. If the M1XSP has jumper S4, set it to =1. Set Jumper JP3 to the "485" position. The BAUD jumpers S1,S2, & S3 do not matter as the RCS baud rate is preset internally.
4. Using a 4 conductor cable and the diagram below, connect each wire from the RS-485 terminals on the RCS Thermostat Control unit to the RS-485 terminals on the M1XSP. The supplied WO37A cable (RS-232) is not used.
5. Power up the RCS Thermostat Control Unit.
6. Program the Unit Address and any other options in the RCS Unit per its instructions. The unit address must match the Thermostat number in the M1 Control. The first Thermostat should be Address 1.
7. Using the NESS-RP Software, program the M1 using the following steps. Test and verify operation using steps d and e.
  - 7a. Click on the Automation Tab in the NESS-RP software. Click on Thermostat icon and program a name for Thermostat 1.
  - 7b. Click on the Task icon and program at least two tasks. Name the 1st Task "Economy Mode" and the 2nd "Comfort Mode".
  - 7c. Click on the Rules icon and create the following 4 rules.

Whenever [Area Name] Armed State Becomes Armed Away  
Then Activate [Economy Mode] (Task 1)

Whenever [Task Name] (Task 1) Is Activated  
Then Set [Thermostat 1] (TStat 1) Cooling Desired Temp to 30 degrees

Whenever [Area] Armed State Becomes Disarmed  
Then Activate [Comfort Mode] (Task 2)

Whenever [Task Name] (Task 2) Is Activated  
Then Set [Thermostat 1] (TStat 1) Cooling Desired Temp to 21 degrees

- 7d. Use the M1 Keypad to verify the M1XSP & Thermostat operation. Press the ELK key followed by the Right arrow key to access Menu 1-View/Control Automation Fncts. Press 6 for the Thermostat Temperature sub-menu, followed by Right arrow key. The Keypad should display the first Thermostat (T01) along with its name and current temperature reading.
- 7e. Go into the Tasks sub-menu and select Economy Mode (Task 1). Press the # key to activate. When this task is activated the thermostat cooling setpoint should go to 30 degrees. Confirm this on the thermostat display.

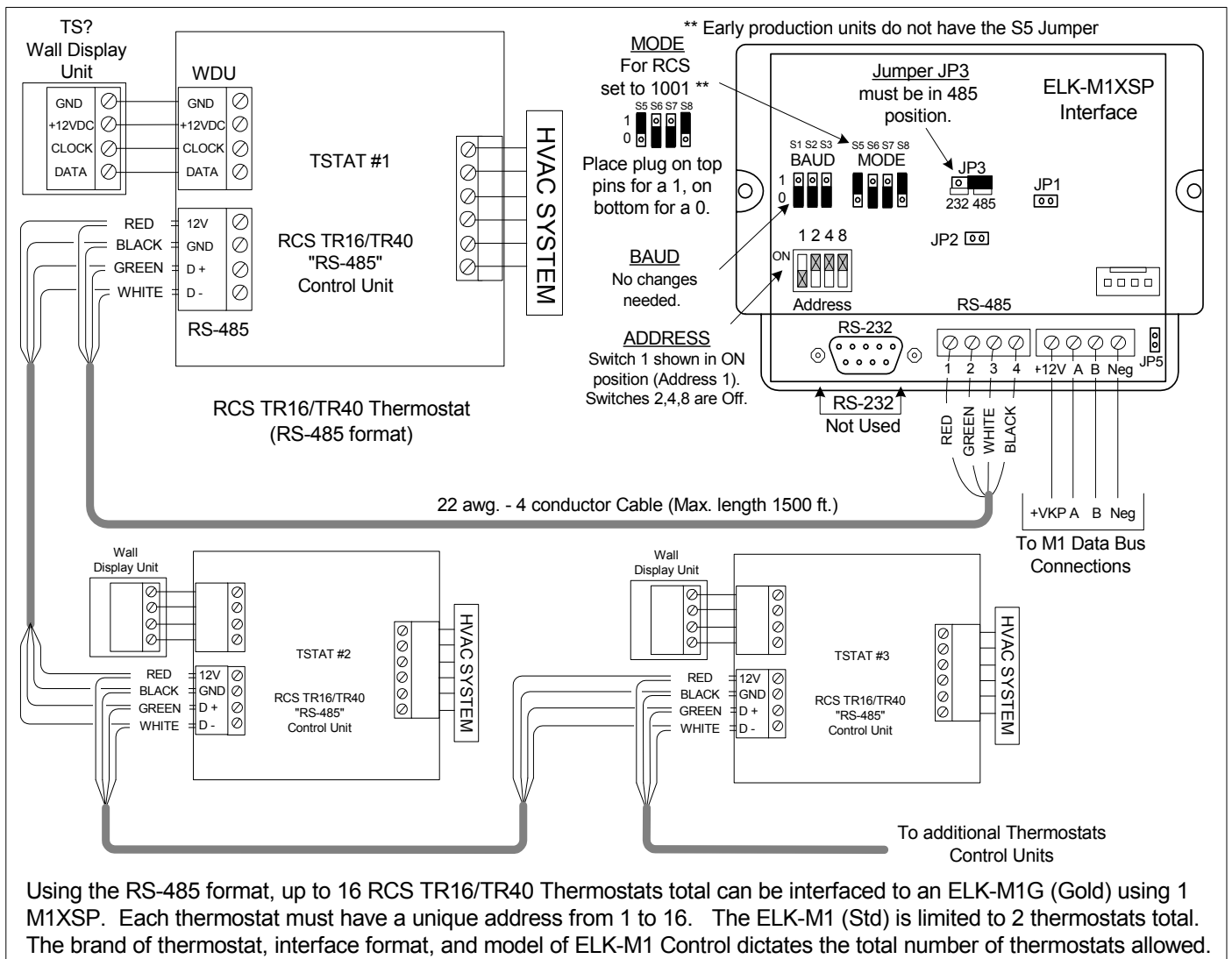

# HAI RC Series (RS-232 Format) Thermostat(s)

1. Install, and wire the HAI Thermostat to the HVAC system per the instructions that came with the thermostat.
2. Install the ELK-M1XSP as per instructions on page 3. Enroll the device into the M1 after setting the data bus address switches. **IMPORTANT: Refer to wiring diagram below and the note regarding which data bus addresses to use.**
3. Set the MODE jumpers S5=1, S6=0, S7=1, & S8=0 for HAI mode. If the M1XSP has jumper S4, set it to =1. Set Jumper JP3 to the "232" position. The BAUD jumpers S1,S2, & S3 do not matter as the HAI baud rate is preset internally.
4. Using a four wire cable and some splice connectors, connect the WO37A cable which is supplied with the NESS-M1XSP to the Black, Red, Green, and Yellow wires of the four pin flying lead cable that is supplied with the HAI Thermostat. Plug the WO37A cable into the 9 pin serial connector on the M1XSP, then plug the four pin cable into the HAI Thermostat.
5. Power up the HAI Thermostat, enter the Installer Setup Mode (see page 10 of the HAI manual), and program the following:
  - A. Set Item #00 "Address" to a value from 1 to 16. The first unit should be address 1. If multiple thermostats are installed, each should be set to a consecutive address, starting at 1.
  - B. Set Item #01 "Communications Mode" to a value of 0 (300 baud, RS-232 mode).
  - C. Set Item #03 "Display Options" to one of the options designated as "non-programmable" (4 thru 7). This disables the thermostat's internal setback time schedules so they do not override the M1 Automation commands from the M1XSP.  
*An alternate method is to disable specific schedules by setting their times values to "----" (1 step past the 11:45pm time set).*
  - D. Set Items #05 & #06 "Cool Setpoint Limit" and "Heat Setpoint Limit" (if desired). **CAUTION: The thermostat will ignore any setpoint commands sent to it that are outside these limits.**
6. Using the NESS-RP Software, program steps A,B, and C. Test and verify operation using steps D and E.
  - 6a. Click on the Automation Tab in the NESS-RP software. Click on Thermostat icon and program a name for Thermostat 1.
  - 6b. Click on the Task icon and program at least two tasks. Name the 1st Task "Economy Mode" and the 2nd "Comfort Mode".
  - 6c. Click on the Rules icon and create the following 4 rules.
 

<p>Whenever [Area Name] Armed State Becomes Armed Away Then Activate [Economy Mode] (Task 1)</p> <p>Whenever [Area] Armed State Becomes Disarmed Then Activate [Comfort Mode] (Task 2)</p>	<p>Whenever [Task Name] (Task 1) Is Activated Then Set [Thermostat 1] (TStat 1) Cooling Desired Temp to 30 degrees</p> <p>Whenever [Task Name] (Task 2) Is Activated Then Set [Thermostat 1] (TStat 1) Cooling Desired Temp to 21 degrees</p>
--	---
  - 6d. Use the M1 Keypad to verify the M1XSP & Thermostat operation. Press the ELK key followed by the Right arrow key to access Menu 1-View/Control Automation Fncts. Press 6 for the Thermostat Temperature sub-menu, followed by Right arrow key. The Keypad should display the first Thermostat (T01) along with its name and current temperature reading.
  - 6e. Go into the Tasks sub-menu and select Economy Mode (Task 1). Press the # key to activate. When this task is activated the thermostat cooling setpoint should go to 30 degrees. Confirm this on the display.

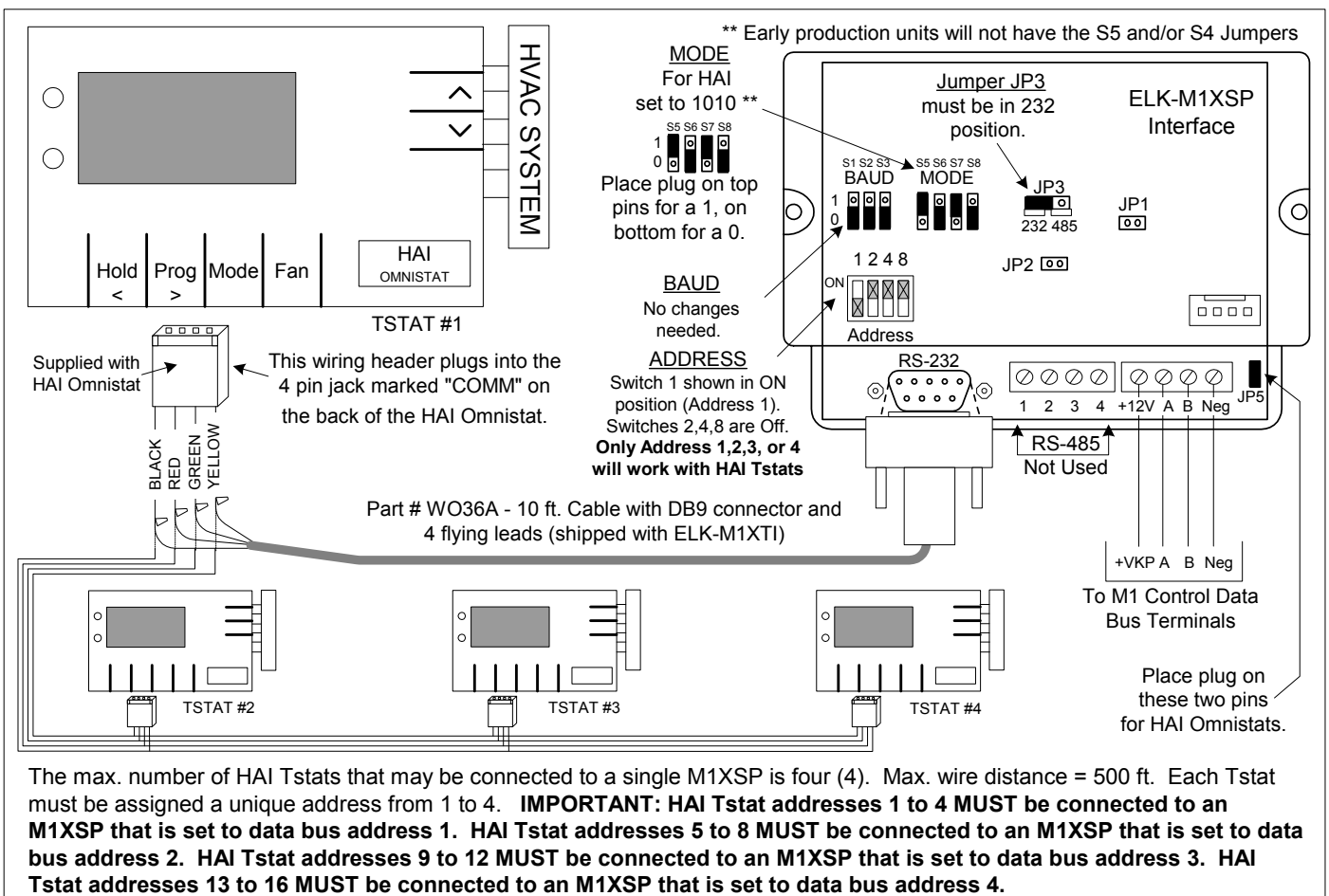

# Lighting Controllers with RS-232 "Serial" Interfaces

**Examples: C-Bus (via Ness C-Bus module), OnQ-ALC, PCS-UPB, Centralite, Lutron, Vantage, EDT-iLine, etc.**

1. Install Lighting Controller using the instructions provided by the manufacturer. If the Lighting Controller's interface has an address setting then set it to address 1. Most controllers do not require an address setting.
3. Install the Ness-M1XSP per the instructions on page 3.
4. Set Jumper JP3 to the "232" position.
5. Set the MODE jumpers to match the particular brand of lighting controller. See chart on page 10.
6. Set the BAUD rate jumpers to **000**. (The M1XSP automatically sets the baud rate based on the MODE Jumper setting)
7. Connect a 9-pin serial cable from the Lighting Controller's serial port to the 9 pin connector on the M1XSP.
8. Apply power to the Lighting Controller and the M1XSP. **DON'T FORGET TO ENROLL THE M1XSP INTO THE M1.**
9. Program and test at least one light device using the NESS-RP Software and the following steps:
  - 9a. Click on the Automation icon, then on the Lighting icon.
  - 9b. Click on Lighting Device 1 and program the Name (1 to 16 characters), Format (manufacturer), and Type (switch, dimmer, appliance). The "Show" box may be left blank or checked ("X"). If this box is checked, the light will be included in the scroll list of the Keypad and Telephone remote (not available in EZ8) View/Control Automation menus. If not selected for "Show" the light will be available **ONLY** by manually entering the 3 digit number. Click on the Voice Description (not available in EZ8) to program a 1 to 6 word voice description for this light. Right click on Light 1 and select "Send Lighting 1" to send this programming to the M1.
  - 9c. Click on the Rules icon and create the following 2 test rules.

Test Rule 1: WHENEVER 'Name' (Area 1) IS ARMED AWAY  
THEN TURN 'Name' [1 [A1]] ON

Test Rule 2: WHENEVER 'Name' (Area 1) IS DISARMED  
THEN TURN 'Name' [1 [A1]] OFF

- 9d. Click "Send" to transmit these rules to the M1.
- 9e. Test the manual activation of this light by pressing the "ELK" key on the M1 Keypad followed by the Right arrow key to select "Menu 1-View/Control Automation Fncts. Press 2 for the Lighting submenu, followed by the Right arrow key. The keypad will display the first Light name and number along with its On or Off status. Note: The status will not be correct if the M1 had been powered off. To change the light from On to Off or from Off to On, press the # key.
- 9f. Test the two automation rules by arming the control to the Away mode. The light should come On. Disarming the M1 should cause the light to turn Off.
10. This confirms the operation. Continue to add or test additional lights as required.

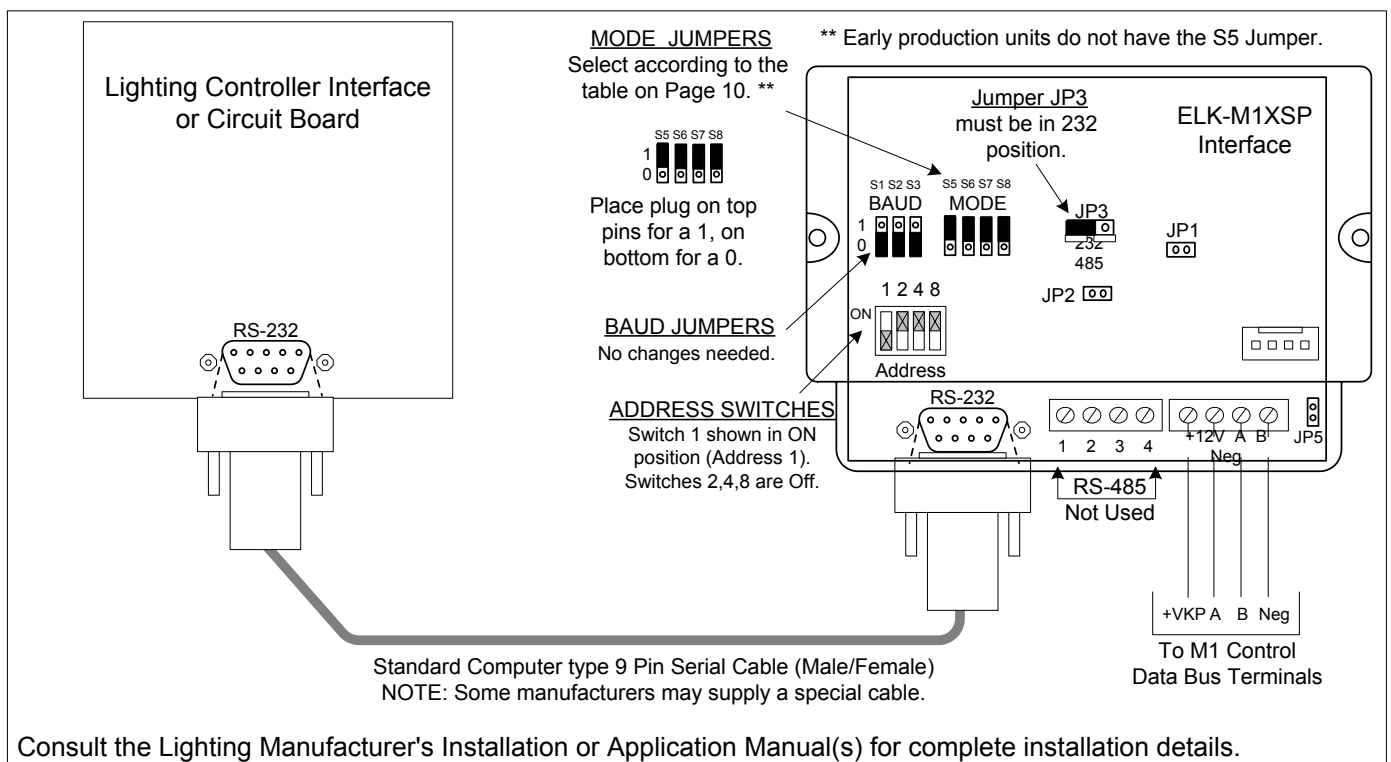

Consult the Lighting Manufacturer's Installation or Application Manual(s) for complete installation details.

## OnQ-ALC - (Individual Lighting Switches)

M1 Lighting devices 1-31 are mapped to activate OnQ ALC Branch 1 "Dimmers/Switches" 1-31 (On, Off, or Dim) respectively. With an ALC expander board, M1 can activate Branches 2, 3, and 4 Dimmer/Switches which will be mapped as Light devices 33-63, 65-95, and 97-127. Light devices 32, 64, 96, and 128 are mapped to the ALC "Virtual Scenes" 1 thru 4. Use Ness-RP to program lights 1-128 as **"Format=Serial Expander"**, **"Type=Dimmer"**. When a M1 Light device is activated from a rule-of from the M1 Keypad "Automation" menu, the corresponding ALC serial command is sent from the M1XSP. Note: Dimming from the Keypad can only be done using a task. The chart below shows the M1 Lighting devices and their corresponding ALC Switches.

- Connect the NESS-M1XSP to the OnQ ALC Serial Interface Module #364726-01 using a 9 pin Serial Cable. The OnQ Lighting Controller #364644-01 is then connected to the OnQ Serial Interface. Option expansion module #364726-01 is required to obtain the full capacity of 124 Switches.
- Set the M1XSP Jumpers to: **JP3="232"**, Mode Jumper **S4\*="1" (UP)**, **S5="1" (UP)**, **S6="1" (UP)**, **S7="0" (DN)**, **S8="0" (DN)**.  
\*Some boards MAY NOT have the S4 jumper. The position of BAUD jumpers S1,S2,S3 does not matter.
- Be sure to set the address switches on the ALC switches and use the OnQ Software to program the features.

ELK Light Device #	PLC (X-10) Ref.	OnQ-ALC Branch / Switch	ELK Light Device #	PLC (X-10) Ref.	OnQ-ALC Branch / Switch	ELK Light Device #	PLC (X-10) Ref.	OnQ-ALC Branch/Node/SS Scene Switch	ELK Light Device #	PLC (X-10) Ref.	OnQ-ALC Branch/Node/SS Scene Switch
1	A01	B1 Switch 1	65	E01	B3 Switch 1	129	I01	B1/Node1/SS 2	193	M01	B1/Node22/SS 3
2	A02	B1 Switch 2	66	E02	B3 Switch 2	130	I02	B1/Node1/SS 3	194	M02	B1/Node22/SS 4
3	A03	B1 Switch 3	67	E03	B3 Switch 3	131	I03	B1/Node1/SS 4	195	M03	B1/Node23/SS 2
4	A04	B1 Switch 4	68	E04	B3 Switch 4	132	I04	B1/Node2/SS 2	196	M04	B1/Node23/SS 3
5	A05	B1 Switch 5	69	E05	B3 Switch 5	133	I05	B1/Node2/SS 3	197	M05	B1/Node23/SS 4
6	A06	B1 Switch 6	70	E06	B3 Switch 6	134	I06	B1/Node2/SS 4	198	M06	B1/Node24/SS 2
7	A07	B1 Switch 7	71	E07	B3 Switch 7	135	I07	B1/Node3/SS 2	199	M07	B1/Node24/SS 3
8	A08	B1 Switch 8	72	E08	B3 Switch 8	136	I08	B1/Node3/SS 3	200	M08	B1/Node24/SS 4
9	A09	B1 Switch 9	73	E09	B3 Switch 9	137	I09	B1/Node3/SS 4	201	M09	B1/Node25/SS 2
10	A10	B1 Switch 10	74	E10	B3 Switch 10	138	I10	B1/Node4/SS 2	202	M10	B1/Node25/SS 3
11	A11	B1 Switch 11	75	E11	B3 Switch 11	139	I11	B1/Node4/SS 3	203	M11	B1/Node25/SS 4
12	A12	B1 Switch 12	76	E12	B3 Switch 12	140	I12	B1/Node4/SS 4	204	M12	B1/Node26/SS 2
13	A13	B1 Switch 13	77	E13	B3 Switch 13	141	I13	B1/Node5/SS 2	205	M13	B1/Node26/SS 3
14	A14	B1 Switch 14	78	E14	B3 Switch 14	142	I14	B1/Node5/SS 3	206	M14	B1/Node26/SS 4
15	A15	B1 Switch 15	79	E15	B3 Switch 15	143	I15	B1/Node5/SS 4	207	M15	B1/Node27/SS 2
16	A16	B1 Switch 16	80	E16	B3 Switch 16	144	I16	B1/Node6/SS 2	208	M16	B1/Node27/SS 3
17	B01	B1 Switch 17	81	F01	B3 Switch 17	145	J01	B1/Node6/SS 3	209	N01	B1/Node27/SS 4
18	B02	B1 Switch 18	82	F02	B3 Switch 18	146	J02	B1/Node6/SS 4	210	N02	B1/Node28/SS 2
19	B03	B1 Switch 19	83	F03	B3 Switch 19	147	J03	B1/Node7/SS 2	211	N03	B1/Node28/SS 3
20	B04	B1 Switch 20	84	F04	B3 Switch 20	148	J04	B1/Node7/SS 3	212	N04	B1/Node28/SS 4
21	B05	B1 Switch 21	85	F05	B3 Switch 21	149	J05	B1/Node7/SS 4	213	N05	B1/Node29/SS 2
22	B06	B1 Switch 22	86	F06	B3 Switch 22	150	J06	B1/Node8/SS 2	214	N06	B1/Node29/SS 3
23	B07	B1 Switch 23	87	F07	B3 Switch 23	151	J07	B1/Node8/SS 3	215	N07	B1/Node29/SS 4
24	B08	B1 Switch 24	88	F08	B3 Switch 24	152	J08	B1/Node8/SS 4	216	N08	B1/Node30/SS 2
25	B09	B1 Switch 25	89	F09	B3 Switch 25	153	J09	B1/Node9/SS 2	217	N09	B1/Node30/SS 3
26	B20	B1 Switch 26	90	F10	B3 Switch 26	154	J10	B1/Node9/SS 3	218	N10	B1/Node30/SS 4
27	B21	B1 Switch 27	91	F11	B3 Switch 27	155	J11	B1/Node9/SS 4	219	N11	B1/Node31/SS 2
28	B22	B1 Switch 28	92	F12	B3 Switch 28	156	J12	B1/Node10/SS 2	220	N12	B1/Node31/SS 3
29	B23	B1 Switch 29	93	F13	B3 Switch 29	157	J13	B1/Node10/SS 3	221	N13	B1/Node31/SS 4
30	B24	B1 Switch 30	94	F14	B3 Switch 30	158	J14	B1/Node10/SS 4	222	N14	
31	B25	B1 Switch 31	95	F15	B3 Switch 31	159	J15	B1/Node11/SS 2	223	N15	
32	B26	Virtual Scene 1	96	F16	Virtual Scene 3	160	J16	B1/Node11/SS 3	224	N16	
33	C01	B2 Switch 1	97	G01	B4 Switch 1	161	K01	B1/Node11/SS 4	225	O01	
34	C02	B2 Switch 2	98	G02	B4 Switch 2	162	K02	B1/Node12/SS 2	226	O02	
35	C03	B2 Switch 3	99	G03	B4 Switch 3	163	K03	B1/Node12/SS 3	227	O03	
36	C04	B2 Switch 4	100	G04	B4 Switch 4	164	K04	B1/Node12/SS 4	228	O04	
37	C05	B2 Switch 5	101	G05	B4 Switch 5	165	K05	B1/Node13/SS 2	229	O05	
38	C06	B2 Switch 6	102	G06	B4 Switch 6	166	K06	B1/Node13/SS 3	230	O06	
39	C07	B2 Switch 7	103	G07	B4 Switch 7	167	K07	B1/Node13/SS 4	231	O07	
40	C08	B2 Switch 8	104	G08	B4 Switch 8	168	K08	B1/Node14/SS 2	232	O08	
41	C09	B2 Switch 9	105	G09	B4 Switch 9	169	K09	B1/Node14/SS 3	233	O09	
42	C10	B2 Switch 10	106	G10	B4 Switch 10	170	K10	B1/Node14/SS 4	234	O10	
43	C11	B2 Switch 11	107	G11	B4 Switch 11	171	K11	B1/Node15/SS 2	235	O11	
44	C12	B2 Switch 12	108	G12	B4 Switch 12	172	K12	B1/Node15/SS 3	236	O12	
45	C13	B2 Switch 13	109	G13	B4 Switch 13	173	K13	B1/Node15/SS 4	237	O13	
46	C14	B2 Switch 14	110	G14	B4 Switch 14	174	K14	B1/Node16/SS 2	238	O14	
47	C15	B2 Switch 15	111	G15	B4 Switch 15	175	K15	B1/Node16/SS 3	239	O15	
48	C16	B2 Switch 16	112	G16	B4 Switch 16	176	K16	B1/Node16/SS 4	240	O16	
49	D01	B2 Switch 17	113	H01	B4 Switch 17	177	L01	B1/Node17/SS 2	241	P01	
50	D02	B2 Switch 18	114	H02	B4 Switch 18	178	L02	B1/Node17/SS 3	242	P02	
51	D03	B2 Switch 19	115	H03	B4 Switch 19	179	L03	B1/Node17/SS 4	243	P03	
52	D04	B2 Switch 20	116	H04	B4 Switch 20	180	L04	B1/Node18/SS 2	244	P04	
53	D05	B2 Switch 21	117	H05	B4 Switch 21	181	L05	B1/Node18/SS 3	245	P05	
54	D06	B2 Switch 22	118	H06	B4 Switch 22	182	L06	B1/Node18/SS 4	246	P06	
55	D07	B2 Switch 23	119	H07	B4 Switch 23	183	L07	B1/Node19/SS 2	247	P07	
56	D08	B2 Switch 24	120	H08	B4 Switch 24	184	L08	B1/Node19/SS 3	248	P08	
57	D09	B2 Switch 25	121	H09	B4 Switch 25	185	L09	B1/Node19/SS 4	249	P09	
58	D10	B2 Switch 26	122	H10	B4 Switch 26	186	L10	B1/Node20/SS 2	250	P10	
59	D11	B2 Switch 27	123	H11	B4 Switch 27	187	L11	B1/Node20/SS 3	251	P11	
60	D12	B2 Switch 28	124	H12	B4 Switch 28	188	L12	B1/Node20/SS 4	252	P12	
61	D13	B2 Switch 29	125	H13	B4 Switch 29	189	L13	B1/Node21/SS 2	253	P13	
62	D14	B2 Switch 30	126	H14	B4 Switch 30	190	L14	B1/Node21/SS 3	254	P14	
63	D15	B2 Switch 31	127	H15	B4 Switch 31	191	L15	B1/Node21/SS 4	255	P15	
64	D16	Virtual Scene 2	128	H16	Virtual Scene 4	192	L16	B1/Node22/SS 2	256	P16	

The PLC column is for reference only.

## UPB - (Individual Lighting Loads and Links)

M1 Lighting devices 1-192 are mapped to activate UPB "Dimmers/Switches" 1-192 (On, Off, or Dim) respectively. Use NessRP to program lights 1-192 as "Format=Serial Expander", "Type=Dimmer". Light devices 193-256 are mapped to activate UPB "Link" (Scenes) 1-64. Use Elk-RP to program light devices 193-256 as "Format= Serial Expander", "Type=On/Off Switch". When a M1 Light device is activated from a rule of from the M1 Keypad "Automation" menu, the corresponding UPB serial command is sent from the M1XSP. Note: Dimming from the Keypad can only be done using a task. The chart below shows the M1 Lighting devices and their corresponding UPB Modules and Links.

- Connect the Ness-M1XSP to the UPB "PIM" or "CIM" (Programming/Computer interface Module) using a 9 pin Serial Cable.
- Set the M1XSP Jumpers to: JP3="232", Mode Jumper S4="1" (UP), S5="1" (UP), S6="1" (UP), S7="0" (DN), S8="1" (UP).  
\*Some boards MAY NOT have the S4 jumper. The position of BAUD jumpers S1,S2,S3 does not matter.
- Use the UPB UPStart Software to program the UPB modules with an address, network ID, and any other options.
- To receive "Load Status" changes program the option bit "Transmit Changes" from the UPStart software.
- **IMPORTANT: The unique UPB NETWORK ID programmed and stored in the UPB switches must also be programmed into the M1 using the NessRP software.** Refer to the NessRP software, "Globals" folder, "G29-G42 Special" tab.

ELK Light Device #	PLC (X-10) Ref.	UPB	ELK Light Device #	PLC (X-10) Ref.	UPB	ELK Light Device #	PLC (X-10) Ref.	UPB	ELK Light Device #	PLC (X-10) Ref.	UPB	The PLC column is for reference only.	
1	A01	Switch 1	65	E01	Switch 65	129	I01	Switch 129	193	M01	Link (Scene) 01		
2	A02	Switch 2	66	E02	Switch 66	130	I02	Switch 130	194	M02	Link (Scene) 02		
3	A03	Switch 3	67	E03	Switch 67	131	I03	Switch 131	195	M03	Link (Scene) 03		
4	A04	Switch 4	68	E04	Switch 68	132	I04	Switch 132	196	M04	Link (Scene) 04		
5	A05	Switch 5	69	E05	Switch 69	133	I05	Switch 133	197	M05	Link (Scene) 05		
6	A06	Switch 6	70	E06	Switch 70	134	I06	Switch 134	198	M06	Link (Scene) 06		
7	A07	Switch 7	71	E07	Switch 71	135	I07	Switch 135	199	M07	Link (Scene) 07		
8	A08	Switch 8	72	E08	Switch 72	136	I08	Switch 136	200	M08	Link (Scene) 08		
9	A09	Switch 9	73	E09	Switch 73	137	I09	Switch 137	201	M09	Link (Scene) 09		
10	A10	Switch 10	74	E10	Switch 74	138	I10	Switch 138	202	M10	Link (Scene) 10		
11	A11	Switch 11	75	E11	Switch 75	139	I11	Switch 139	203	M11	Link (Scene) 11		
12	A12	Switch 12	76	E12	Switch 76	140	I12	Switch 140	204	M12	Link (Scene) 12		
13	A13	Switch 13	77	E13	Switch 77	141	I13	Switch 141	205	M13	Link (Scene) 13		
14	A14	Switch 14	78	E14	Switch 78	142	I14	Switch 142	206	M14	Link (Scene) 14		
15	A15	Switch 15	79	E15	Switch 79	143	I15	Switch 143	207	M15	Link (Scene) 15		
16	A16	Switch 16	80	E16	Switch 80	144	I16	Switch 144	208	M16	Link (Scene) 16		
17	B01	Switch 17	81	F01	Switch 81	145	J01	Switch 145	209	N01	Link (Scene) 17		
18	B02	Switch 18	82	F02	Switch 82	146	J02	Switch 146	210	N02	Link (Scene) 18		
19	B03	Switch 19	83	F03	Switch 83	147	J03	Switch 147	211	N03	Link (Scene) 19		
20	B04	Switch 20	84	F04	Switch 84	148	J04	Switch 148	212	N04	Link (Scene) 20		
21	B05	Switch 21	85	F05	Switch 85	149	J05	Switch 149	213	N05	Link (Scene) 21		
22	B06	Switch 22	86	F06	Switch 86	150	J06	Switch 150	214	N06	Link (Scene) 22		
23	B07	Switch 23	87	F07	Switch 87	151	J07	Switch 151	215	N07	Link (Scene) 23		
24	B08	Switch 24	88	F08	Switch 88	152	J08	Switch 152	216	N08	Link (Scene) 24		
25	B09	Switch 25	89	F09	Switch 89	153	J09	Switch 153	217	N09	Link (Scene) 25		
26	B10	Switch 26	90	F10	Switch 90	154	J10	Switch 154	218	N10	Link (Scene) 26		
27	B11	Switch 27	91	F11	Switch 91	155	J11	Switch 155	219	N11	Link (Scene) 27		
28	B12	Switch 28	92	F12	Switch 92	156	J12	Switch 156	220	N12	Link (Scene) 28		
29	B13	Switch 29	93	F13	Switch 93	157	J13	Switch 157	221	N13	Link (Scene) 29		
30	B14	Switch 30	94	F14	Switch 94	158	J14	Switch 158	222	N14	Link (Scene) 30		
31	B15	Switch 31	95	F15	Switch 95	159	J15	Switch 159	223	N15	Link (Scene) 31		
32	B16	Switch 32	96	F16	Switch 96	160	J16	Switch 160	224	N16	Link (Scene) 32		
33	C01	Switch 33	97	G01	Switch 97	161	K01	Switch 161	225	O01	Link (Scene) 33		
34	C02	Switch 34	98	G02	Switch 98	162	K02	Switch 162	226	O02	Link (Scene) 34		
35	C03	Switch 35	99	G03	Switch 99	163	K03	Switch 163	227	O03	Link (Scene) 35		
36	C04	Switch 36	100	G04	Switch 100	164	K04	Switch 164	228	O04	Link (Scene) 36		
37	C05	Switch 37	101	G05	Switch 101	165	K05	Switch 165	229	O05	Link (Scene) 37		
38	C06	Switch 38	102	G06	Switch 102	166	K06	Switch 166	230	O06	Link (Scene) 38		
39	C07	Switch 39	103	G07	Switch 103	167	K07	Switch 167	231	O07	Link (Scene) 39		
40	C08	Switch 40	104	G08	Switch 104	168	K08	Switch 168	232	O08	Link (Scene) 40		
41	C09	Switch 41	105	G09	Switch 105	169	K09	Switch 169	233	O09	Link (Scene) 41		
42	C10	Switch 42	106	G10	Switch 106	170	K10	Switch 170	234	O10	Link (Scene) 42		
43	C11	Switch 43	107	G11	Switch 107	171	K11	Switch 171	235	O11	Link (Scene) 43		
44	C12	Switch 44	108	G12	Switch 108	172	K12	Switch 172	236	O12	Link (Scene) 44		
45	C13	Switch 45	109	G13	Switch 109	173	K13	Switch 173	237	O13	Link (Scene) 45		
46	C14	Switch 46	110	G14	Switch 110	174	K14	Switch 174	238	O14	Link (Scene) 46		
47	C15	Switch 47	111	G15	Switch 111	175	K15	Switch 175	239	O15	Link (Scene) 47		
48	C16	Switch 48	112	G16	Switch 112	176	K16	Switch 176	240	O16	Link (Scene) 48		
49	D01	Switch 49	113	H01	Switch 113	177	L01	Switch 177	241	P01	Link (Scene) 49		
50	D02	Switch 50	114	H02	Switch 114	178	L02	Switch 178	242	P02	Link (Scene) 50		
51	D03	Switch 51	115	H03	Switch 115	179	L03	Switch 179	243	P03	Link (Scene) 51		
52	D04	Switch 52	116	H04	Switch 116	180	L04	Switch 180	244	P04	Link (Scene) 52		
53	D05	Switch 53	117	H05	Switch 117	181	L05	Switch 181	245	P05	Link (Scene) 53		
54	D06	Switch 54	118	H06	Switch 118	182	L06	Switch 182	246	P06	Link (Scene) 54		
55	D07	Switch 55	119	H07	Switch 119	183	L07	Switch 183	247	P07	Link (Scene) 55		
56	D08	Switch 56	120	H08	Load 120	184	L08	Switch 184	248	P08	Link (Scene) 56		
57	D09	Switch 57	121	H09	Load 121	185	L09	Switch 185	249	P09	Link (Scene) 57		
58	D10	Switch 58	122	H10	Load 122	186	L10	Switch 186	250	P10	Link (Scene) 58		
59	D11	Switch 59	123	H11	Load 123	187	L11	Switch 187	251	P11	Link (Scene) 59		
60	D12	Switch 60	124	H12	Load 124	188	L12	Switch 188	252	P12	Link (Scene) 60		
61	D13	Switch 61	125	H13	Load 125	189	L13	Switch 189	253	P13	Link (Scene) 61		
62	D14	Switch 62	126	H14	Load 126	190	L14	Switch 190	254	P14	Link (Scene) 62		
63	D15	Switch 63	127	H15	Load 127	191	L15	Switch 191	255	P15	Link (Scene) 63		
64	D16	Switch 64	128	H16	Load 128	192	L16	Switch 192	256	P16	Link (Scene) 64		

## Centralite LiteJet - (Individual Lighting Loads and Scenes)

M1 Lighting devices 1-192 are mapped to activate Centralite "Loads" 1-192 (On, Off, or Dim) respectively. Use NessRP to program lights 1-192 as "Format=Serial Expander", Type =Dimmer". Light devices 193-256 are mapped to activate Centralite "Scenes" 1-64. Use NessRP to program light devices 193-256 as "Format= Serial Expander", "Type=On/Off Switch". When a M1 Light device is activated from a rule or from the M1 Keypad "Automation" menu, the corresponding Centralite serial command (load or scene) is sent from the M1XSP. NOTE: Dimming from the Keypad can only be done using a task. NOTE: The M1 cannot directly react to a button press from a Centralite keypad, however it is possible to assign a button to a non physical (phantom) load and then use the status change of that load to cause an M1 action. The chart below shows the M1 Lighting devices and their corresponding Centralite Load/Scenes. Centralite commands sent by the M1XSP: ^Annn<cr>=Load ON, ^Bnnn<cr>=Load Off, ^Cnnn<cr>=Scene On, ^Dnnn<cr>=Scene Off, and ^Ennnllrr<cr>=Load, Level, & Ramp Rate. Where "nnn" represents the load or scene 001-256, "ll" represents the dim Level 00-99, and "rr" represents the ramp rate 00-31.

- Connect the ELK-M1XSP to the Centralite Load Center Processor board using a 9 pin Serial Cable.
- Set the M1XSP Jumpers to: **JP3="232"**, Mode Jumper **S4="1" (UP)**, **S5="1" (UP)**, **S6="1" (UP)**, **S7="1" (UP)**, **S8="0" (DN)**.  
 \*Some boards MAY NOT have the S4 jumper. The position of BAUD jumpers S1,S2,S3 does not matter.
- To receive load status changes from Centralite requires firmware **ver 1.0.14 or later in the M1XSP** and **ver 5.5 in the LiteJet**. Turn ON dipswitch 6 on the LiteJet board but DO NOT program the load "send changes" option. Note: Centralite places a 1 second delay between each load change so the response is non instantaneous. An ALL ON can take over a minute.

ELK Light Device #	PLC (X-10) Ref.	Centralite	ELK Light Device #	PLC (X-10) Ref.	Centralite	ELK Light Device #	PLC (X-10) Ref.	Centralite	ELK Light Device #	PLC (X-10) Ref.	Centralite
1	A01	Load 1	65	E01	Load 65	129	I01	Load 129	193	M01	Scene 01 All On
2	A02	Load 2	66	E02	Load 66	130	I02	Load 130	194	M02	Scene 02 All Off
3	A03	Load 3	67	E03	Load 67	131	I03	Load 131	195	M03	Scene 03 Vacation
4	A04	Load 4	68	E04	Load 68	132	I04	Load 132	196	M04	Scene 04 Alarm Flash
5	A05	Load 5	69	E05	Load 69	133	I05	Load 133	197	M05	Scene 05 Pwr-up Override
6	A06	Load 6	70	E06	Load 70	134	I06	Load 134	198	M06	Scene 06
7	A07	Load 7	71	E07	Load 71	135	I07	Load 135	199	M07	Scene 07
8	A08	Load 8	72	E08	Load 72	136	I08	Load 136	200	M08	Scene 08
9	A09	Load 9	73	E09	Load 73	137	I09	Load 137	201	M09	Scene 09
10	A10	Load 10	74	E10	Load 74	138	I10	Load 138	202	M10	Scene 10
11	A11	Load 11	75	E11	Load 75	139	I11	Load 139	203	M11	Scene 11
12	A12	Load 12	76	E12	Load 76	140	I12	Load 140	204	M12	Scene 12
13	A13	Load 13	77	E13	Load 77	141	I13	Load 141	205	M13	Scene 13
14	A14	Load 14	78	E14	Load 78	142	I14	Load 142	206	M14	Scene 14
15	A15	Load 15	79	E15	Load 79	143	I15	Load 143	207	M15	Scene 15
16	A16	Load 16	80	E16	Load 80	144	I16	Load 144	208	M16	Scene 16
17	B01	Load 17	81	F01	Load 81	145	J01	Load 145	209	N01	Scene 17
18	B02	Load 18	82	F02	Load 82	146	J02	Load 146	210	N02	Scene 18
19	B03	Load 19	83	F03	Load 83	147	J03	Load 147	211	N03	Scene 19
20	B04	Load 20	84	F04	Load 84	148	J04	Load 148	212	N04	Scene 20
21	B05	Load 21	85	F05	Load 85	149	J05	Load 149	213	N05	Scene 21
22	B06	Load 22	86	F06	Load 86	150	J06	Load 150	214	N06	Scene 22
23	B07	Load 23	87	F07	Load 87	151	J07	Load 151	215	N07	Scene 23
24	B08	Load 24	88	F08	Load 88	152	J08	Load 152	216	N08	Scene 24
25	B09	Load 25	89	F09	Load 89	153	J09	Load 153	217	N09	Scene 25
26	B10	Load 26	90	F10	Load 90	154	J10	Load 154	218	N10	Scene 26
27	B11	Load 27	91	F11	Load 91	155	J11	Load 155	219	N11	Scene 27
28	B12	Load 28	92	F12	Load 92	156	J12	Load 156	220	N12	Scene 28
29	B13	Load 29	93	F13	Load 93	157	J13	Load 157	221	N13	Scene 29
30	B14	Load 30	94	F14	Load 94	158	J14	Load 158	222	N14	Scene 30
31	B15	Load 31	95	F15	Load 95	159	J15	Load 159	223	N15	Scene 31
32	B16	Load 32	96	F16	Load 96	160	J16	Load 160	224	N16	Scene 32
33	C01	Load 33	97	G01	Load 97	161	K01	Load 161	225	O01	Scene 33
34	C02	Load 34	98	G02	Load 98	162	K02	Load 162	226	O02	Scene 34
35	C03	Load 35	99	G03	Load 99	163	K03	Load 163	227	O03	Scene 35
36	C04	Load 36	100	G04	Load 100	164	K04	Load 164	228	O04	Scene 36
37	C05	Load 37	101	G05	Load 101	165	K05	Load 165	229	O05	Scene 37
38	C06	Load 38	102	G06	Load 102	166	K06	Load 166	230	O06	Scene 38
39	C07	Load 39	103	G07	Load 103	167	K07	Load 167	231	O07	Scene 39
40	C08	Load 40	104	G08	Load 104	168	K08	Load 168	232	O08	Scene 40
41	C09	Load 41	105	G09	Load 105	169	K09	Load 169	233	O09	Scene 41
42	C10	Load 42	106	G10	Load 106	170	K10	Load 170	234	O10	Scene 42
43	C11	Load 43	107	G11	Load 107	171	K11	Load 171	235	O11	Scene 43
44	C12	Load 44	108	G12	Load 108	172	K12	Load 172	236	O12	Scene 44
45	C13	Load 45	109	G13	Load 109	173	K13	Load 173	237	O13	Scene 45
46	C14	Load 46	110	G14	Load 110	174	K14	Load 174	238	O14	Scene 46
47	C15	Load 47	111	G15	Load 111	175	K15	Load 175	239	O15	Scene 47
48	C16	Load 48	112	G16	Load 112	176	K16	Load 176	240	O16	Scene 48
49	D01	Load 49	113	H01	Load 113	177	L01	Load 177	241	P01	Scene 49
50	D02	Load 50	114	H02	Load 114	178	L02	Load 178	242	P02	Scene 50
51	D03	Load 51	115	H03	Load 115	179	L03	Load 179	243	P03	Scene 51
52	D04	Load 52	116	H04	Load 116	180	L04	Load 180	244	P04	Scene 52
53	D05	Load 53	117	H05	Load 117	181	L05	Load 181	245	P05	Scene 53
54	D06	Load 54	118	H06	Load 118	182	L06	Load 182	246	P06	Scene 54
55	D07	Load 55	119	H07	Load 119	183	L07	Load 183	247	P07	Scene 55
56	D08	Load 56	120	H08	Load 120	184	L08	Load 184	248	P08	Scene 56
57	D09	Load 57	121	H09	Load 121	185	L09	Load 185	249	P09	Scene 57
58	D10	Load 58	122	H10	Load 122	186	L10	Load 186	250	P10	Scene 58
59	D11	Load 59	123	H11	Load 123	187	L11	Load 187	251	P11	Scene 59
60	D12	Load 60	124	H12	Load 124	188	L12	Load 188	252	P12	Scene 60
61	D13	Load 61	125	H13	Load 125	189	L13	Load 189	253	P13	Scene 61
62	D14	Load 62	126	H14	Load 126	190	L14	Load 190	254	P14	Scene 62
63	D15	Load 63	127	H15	Load 127	191	L15	Load 191	255	P15	Scene 63
64	D16	Load 64	128	H16	Load 128	192	L16	Load 192	256	P16	Scene 64

***[THIS PAGE INTENTIONALLY LEFT BLANK]***

## Lutron RadioRA - (Phantoms, Zones, Security Flash/Solid, Master Ctrl Buttons)

Interfacing to a Lutron RadioRA System requires: M1XSP Interface with **firmware 1.1.14 or greater**, 9 pin Serial Cable, Lutron RA-RS232 Interface, Dimmers, etc.

- The M1XSP jumper settings should be: **JP3=232** position and **JP5=ON**, Mode Jumper **S4=1** (not all boards have S4 jumper) **S5=0**, **S6=1**, **S7=1**, and **S8=0**. BAUD jumpers S1, S2, & S3 do not matter as the Lutron baud rate is preset internally.
- Plug a standard 9-pin Serial Cable (not included) between the Lutron RA-RS232 DB-9F (female) connector and the M1XSP DB-9M (male) connector. The ELK-WO37A cable that is supplied with the M1XSP will not be utilized.
- Follow the instructions in the Lutron RA-RS232 "Setup and Installation Guide". Activate the RS232 interface (pages 8 & 9). Assign Phantom Buttons as Rooms or Scenes (pages 12 to 25). Assign Zone Numbers if direct control or feedback of an individual zone (device) is desired (pages 26 to 28). Turn Hardware Handshaking OFF by following the instructions on pages 33 and 34. Test the Phantom Button On or Off function locally from the RA-RS232 interface (page 42).
- Use the ELK-RP software to configure the LIGHTING setup for the M1 to control the Lutron Radio RA devices.

ELK Light Device	PLC (X-10) Ref.	Lutron Phantom Buttons	ELK Light Device	PLC (X-10) Ref.	Expanded Zones 2nd Sys as Lights (S2)	ELK Light Device	PLC (X-10) Ref.	Zones 1st Sys as Shades (S1)	ELK Light Device	PLC (X-10) Ref.	Lutron Master Ctrl Buttons
1	A01	Phantom 1	65	E01	Lighting Z1 (S2)	129	I01	Shade Z17 (S1)	193	M01	MC3 All On/Off
2	A02	Phantom 2	66	E02	Lighting Z2 (S2)	130	I02	Shade Z18 (S1)	194	M02	MC4 Btn 1
3	A03	Phantom 3	67	E03	Lighting Z3 (S2)	131	I03	Shade Z19 (S1)	195	M03	MC4 Btn 2
4	A04	Phantom 4	68	E04	Lighting Z4 (S2)	132	I04	Shade Z20 (S1)	196	M04	MC4 Btn 3
5	A05	Phantom 5	69	E05	Lighting Z5 (S2)	133	I05	Shade Z21 (S1)	197	M05	MC4 Btn 4
6	A06	Phantom 6	70	E06	Lighting Z6 (S2)	134	I06	Shade Z22 (S1)	198	M06	MC4 Btn 5
7	A07	Phantom 7	71	E07	Lighting Z7 (S2)	135	I07	Shade Z23 (S1)	199	M07	MC4 All On/Off
8	A08	Phantom 8	72	E08	Lighting Z8 (S2)	136	I08	Shade Z24 (S1)	200	M08	MC5 Btn 1
9	A09	Phantom 9	73	E09	Lighting Z9 (S2)	137	I09	Shade Z25 (S1)	201	M09	MC5 Btn 2
10	A10	Phantom 10	74	E10	Lighting Z10 (S2)	138	I10	Shade Z26 (S1)	202	M10	MC5 Btn 3
11	A11	Phantom 11	75	E11	Lighting Z11 (S2)	139	I11	Shade Z27 (S1)	203	M11	MC5 Btn 4
12	A12	Phantom 12	76	E12	Lighting Z12 (S2)	140	I12	Shade Z28 (S1)	204	M12	MC5 Btn 5
13	A13	Phantom 13	77	E13	Lighting Z13 (S2)	141	I13	Shade Z29 (S1)	205	M13	MC5 All On/Off
14	A14	Phantom 14	78	E14	Lighting Z14 (S2)	142	I14	Shade Z30 (S1)	206	M14	MC6 Btn 1
15	A15	Phantom 15	79	E15	Lighting Z15 (S2)	143	I15	Shade Z31 (S1)	207	M15	MC6 Btn 2
16	A16	B16/17 All On/Off	80	E16	Lighting Z16 (S2)	144	I16	Shade Z32 (S1)	208	M16	MC6 Btn 3
		<b>Security</b>	81	F01	Lighting Z17 (S2)			<b>Zones 2nd Sys as Shades (S2)</b>	209	N01	MC6 Btn 4
		<b>Flash Mode</b>	82	F02	Lighting Z18 (S2)				210	N02	MC6 Btn 5
17	B01	Phantom 1	83	F03	Lighting Z19 (S2)	145	J01	Shade Z1 (S2)	211	N03	MC6 All On/Off
18	B02	Phantom 2	84	F04	Lighting Z20 (S2)	146	J02	Shade Z2 (S2)	212	N04	MC7 Btn 1
19	B03	Phantom 3	85	F05	Lighting Z21 (S2)	147	J03	Shade Z3 (S2)	213	N05	MC7 Btn 2
20	B04	Phantom 4	86	F06	Lighting Z22 (S2)	148	J04	Shade Z4 (S2)	214	N06	MC7 Btn 3
21	B05	Phantom 5	87	F07	Lighting Z23 (S2)	149	J05	Shade Z5 (S2)	215	N07	MC7 Btn 4
22	B06	Phantom 6	88	F08	Lighting Z24 (S2)	150	J06	Shade Z6 (S2)	216	N08	MC7 Btn 5
23	B07	Phantom 7	89	F09	Lighting Z25 (S2)	151	J07	Shade Z7 (S2)	217	N09	MC7 All On/Off
24	B08	Phantom 8	90	F10	Lighting Z26 (S2)	152	J08	Shade Z8 (S2)	218	N10	MC8 Btn 1
25	B09	Phantom 9	91	F11	Lighting Z27 (S2)	153	J09	Shade Z9 (S2)	219	N11	MC8 Btn 2
26	B10	Phantom 10	92	F12	Lighting Z28 (S2)	154	J10	Shade Z10 (S2)	220	N12	MC8 Btn 3
27	B11	Phantom 11	93	F13	Lighting Z29 (S2)	155	J11	Shade Z11 (S2)	221	N13	MC8 Btn 4
28	B12	Phantom 12	94	F14	Lighting Z30 (S2)	156	J12	Shade Z12 (S2)	222	N14	MC8 Btn 5
29	B13	Phantom 13	95	F15	Lighting Z31 (S2)	157	J13	Shade Z13 (S2)	223	N15	MC8 All On/Off
30	B14	Phantom 14	96	F16	Lighting Z32 (S2)	158	J14	Shade Z14 (S2)	224	N16	MC9 Btn 1
31	B15	Phantom 15			<b>Security</b>	159	J15	Shade Z15 (S2)	225	O01	MC9 Btn 2
32	B16	B16 All On/Off			<b>Solid Mode</b>	160	J16	Shade Z16 (S2)	226	O02	MC9 Btn 3
		<b>Zones 1st Sys as Lights (S1)</b>	97	G01	Phantom 1	161	K01	Shade Z17 (S2)	227	O03	MC9 Btn 4
			98	G02	Phantom 2	162	K02	Shade Z18 (S2)	228	O04	MC9 Btn 5
33	C01	Lighting Zn1 (S1)	99	G03	Phantom 3	163	K03	Shade Z19 (S2)	229	O05	MC9 All On/Off
34	C02	Lighting Zn2 (S1)	100	G04	Phantom 4	164	K04	Shade Z20 (S2)	230	O06	MC10 Btn 1
35	C03	Lighting Zn3 (S1)	101	G05	Phantom 5	165	K05	Shade Z21 (S2)	231	O07	MC10 Btn 2
36	C04	Lighting Zn4 (S1)	102	G06	Phantom 6	166	K06	Shade Z22 (S2)	232	O08	MC10 Btn 3
37	C05	Lighting Zn5 (S1)	103	G07	Phantom 7	167	K07	Shade Z23 (S2)	233	O09	MC10 Btn 4
38	C06	Lighting Zn6 (S1)	104	G08	Phantom 8	168	K08	Shade Z24 (S2)	234	O10	MC10 Btn 5
39	C07	Lighting Zn7 (S1)	105	G09	Phantom 9	169	K09	Shade Z25 (S2)	235	O11	MC10 All On/Off
40	C08	Lighting Zn8 (S1)	106	G10	Phantom 10	170	K10	Shade Z26 (S2)	236	O12	MC11 Btn 1
41	C09	Lighting Zn9 (S1)	107	G11	Phantom 11	171	K11	Shade Z27 (S2)	237	O13	MC11 Btn 2
42	C10	Lighting Zn10 (S1)	108	G12	Phantom 12	172	K12	Shade Z28 (S2)	238	O14	MC11 Btn 3
43	C11	Lighting Zn11 (S1)	109	G13	Phantom 13	173	K13	Shade Z29 (S2)	239	O15	MC11 Btn 4
44	C12	Lighting Zn12 (S1)	110	G14	Phantom 14	174	K14	Shade Z30 (S2)	240	O16	MC11 Btn 5
45	C13	Lighting Zn13 (S1)	111	G15	Phantom 15	175	K15	Shade Z31 (S2)	241	P01	MC11 All On/Off
46	C14	Lighting Zn14 (S1)	112	G16	B16 All On/Off	176	K16	Shade Z32 (S2)	242	P02	MC12 Btn 1
47	C15	Lighting Zn15 (S1)			<b>Zones 1st Sys as Shades (S1)</b>			<b>Master Control Buttons</b>	243	P03	MC12 Btn 2
48	C16	Lighting Zn16 (S1)							244	P04	MC12 Btn 3
49	D01	Lighting Zn17 (S1)	113	H01	Shade Z1 (S1)	177	L01	MC1 Btn 1	245	P05	MC12 Btn 4
50	D02	Lighting Zn18 (S1)	114	H02	Shade Z2 (S1)	178	L02	MC1 Btn 2	246	P06	MC12 Btn 5
51	D03	Lighting Zn19 (S1)	115	H03	Shade Z3 (S1)	179	L03	MC1 Btn 3	247	P07	MC12 All On/Off
52	D04	Lighting Zn20 (S1)	116	H04	Shade Z4 (S1)	180	L04	MC1 Btn 4	248	P08	
53	D05	Lighting Zn21 (S1)	117	H05	Shade Z5 (S1)	181	L05	MC1 Btn 5	249	P09	
54	D06	Lighting Zn22 (S1)	118	H06	Shade Z6 (S1)	182	L06	MC1 All On/Off	250	P10	
55	D07	Lighting Zn23 (S1)	119	H07	Shade Z7 (S1)	183	L07	MC2 Btn 1	251	P11	
56	D08	Lighting Zn24 (S1)	120	H08	Shade Z8 (S1)	184	L08	MC2 Btn 2	252	P12	
57	D09	Lighting Zn25 (S1)	121	H09	Shade Z9 (S1)	185	L09	MC2 Btn 3	253	P13	
58	D10	Lighting Zn26 (S1)	122	H10	Shade Z10 (S1)	186	L10	MC2 Btn 4	254	P14	
59	D11	Lighting Zn27 (S1)	123	H11	Shade Z11 (S1)	187	L11	MC2 Btn 5	255	P15	
60	D12	Lighting Zn28 (S1)	124	H12	Shade Z12 (S1)	188	L12	MC2 All On/Off	256	P16	
61	D13	Lighting Zn29 (S1)	125	H13	Shade Z13 (S1)	189	L13	MC3 Btn 1			
62	D14	Lighting Zn30 (S1)	126	H14	Shade Z14 (S1)	190	L14	MC3 Btn 2			
63	D15	Lighting Zn31 (S1)	127	H15	Shade Z15 (S1)	191	L15	MC3 Btn 3			
64	D16	Lighting Zn32 (S1)	128	H16	Shade Z16 (S1)	192	L16	MC3 Btn 4			

## Operation with Lutron RadioRA

Operation with Lutron RadioRA is based on "mapped" assignments to M1 Lighting Devices 1 to 256. Commands to Lutron include: Phantom Button Presses, Direct Zone Control, and Security Mode activation. An M1 rule OR the Keypad "Automation-Lighting" menu can be used to: A) Turn On or Off any of the phantom buttons 1-15 via M1 Lights 1-15. All Phantoms may be turned On or Off at once via M1 Light 16. B) Turn On or Off any individual Lutron zone 1 to 32 (+32 additional zones with a Lutron "bridged" system). C) Set dimmers to specific levels (via rules only). D) Activate the 5 minute timed Security Flash or Security Solid modes assigned to the 15 phantoms. As for received "status" messages from Lutron zones, they can be used to trigger M1 rules. Received state changes from unused Lutron Master Control unit buttons (limited to 7 button models) can be used to trigger M1 rules, provided they are not assigned to any other function. The chart on the previous page and the following paragraphs explain how the M1 Light Devices correspond to various Lutron capabilities.

**M1 Light Devices 1 to 15** correspond to Lutron RA **Phantom Buttons 1 to 15** (Rooms / Scenes) respectively. Whenever one of these 15 M1 Lighting Devices is turned On or Off its corresponding Lutron phantom button is turned On or Off. For each of these devices program the Format to "Serial Expander", the Type to "On/Off Switch", and the Name to describe each phantom button. Each Lutron phantom button (maximum of 15) can control multiple lights.

**M1 Light Device 16** corresponds to Lutron RA **Phantom Buttons 16 and 17** (All On / All Off) respectively. Program the name for light device 16 as "All On/Off". Set the Format to "Serial Expander" and Type to "On/Off Switch". Activating M1 lighting 16 'On' it will send Phantom 16. Activating M1 Lighting 16 'Off' will send Phantom 17.

**M1 Light Devices 17 to 31** correspond to Lutron RA **Security Flash Mode for Phantom Button 1 to 15** respectively. M1 Light 17 can be used to Flash (for 5 minutes) any light(s) assigned to phantom button 1. Phantom 1 will continue flashing for 5 minutes. Program the Format to "Serial Expander", the Type to "On/Off Switch", and the Name describing each phantom.

**M1 Light Device 32** corresponds to Lutron RA **Security Flash Mode All On / All Off** (Phantom Buttons 16 and 17). Activating M1 Light 32 'On' will Flash (for 5 minutes) ALL LIGHTS that are assigned to phantom buttons. Activating M1 Light 32 'Off' will turn off Flash mode and return ALL LIGHTS assigned to phantom buttons to their previous levels. Program the Format to "Serial Expander", the Type to "On/Off Switch", and the Name as "Flash On/Off"..

**M1 Light Devices 33 to 64** correspond to the first 32 Lutron RA **Lighting Dimmer/switch Zones (1 to 32)** in a single "unbridged" system (S1). It is possible to expand Lutron RA with a second system (S2) using a term call "bridging". Consult Lutron for more information. In a "**bridged**" environment, **M1 Light Devices 65 to 96** correspond to the second 32 Lutron RA **Lighting Dimmer/Switch Zones (1 to 32)**. For each zone to be utilized, program the Format to "Serial Expander", the Type to "Dimmer", and the Name to represent the zone being controlled. NOTE: While Lutron does not specifically recommend or require zone number assignment, the advantage of zoning is that it provides direct individual control including On, Off, and Dim, as well as status respond/feedback which can be also be used by M1 to trigger rules.

**M1 Light Devices 97 to 111** correspond to Lutron RA **Security Solid Mode for Phantom Buttons 1 to 15** respectively. M1 Light 97 can be used to turn On Solid (for 5 minutes) any light(s) assigned to phantom button 1. They remain On for 5 minutes. Program the Format to "Serial Expander", the Type to "On/Off Switch", and the Name describing each phantom.

**M1 Light Device 112** corresponds to Lutron RA **Security Solid Mode All On / All Off** (Phantom Buttons 16 and 17). Activating M1 Light 112 'On' turns On Solid (for 5 minutes) ALL LIGHTS that are assigned to phantom buttons. Activating M1 Light 112 'Off' turns Off Solid mode and returns ALL LIGHTS assigned to phantom buttons to their previous levels. Program the Format to "Serial Expander", the Type to "On/Off Switch", and the name as "Solid On/Off".

**M1 Light Devices 113 thru 144** correspond to the first 32 Lutron RA **Window Treatment Zones (1 to 32)** in a single "unbridged" system (S1). In a "**bridged**" environment, **M1 Light Devices 145 to 176** correspond to the second 32 Lutron RA **Window Treatment Zones (1 to 32)**. For each zone to be utilized, program the Format to "Serial Expander", the Type to "Dimmer", and the Name to represent the zone being controlled.

**M1 Light Devices 177 thru 248** correspond to Lutron RA **buttons on Master Control units 1 thru 12**. Unused (unassigned) buttons can be used, with restrictions, to initiate rule triggers in the M1. Buttons that are already assigned to activate or display phantoms or zones SHOULD NOT BE USED as rule triggers simply because the state of the button can be out-of-sync with the M1, preventing a transition change from occurring. NOTE: Master Control units buttons are Receive ONLY. The M1 cannot directly activate or control any of the Master Control unit buttons.

# Clipsal C-Bus Interface

It is possible to interface to Clipsal C-Bus either via Port 0 on the M1G/EZ8 or via the M1XSP.

**Do Not connect to both the M1XSP and Port 0 at the same time.**

This page will describe the installation of the Ness C-Bus interface when connecting to the M1XSP module.

1. install the M1XSP per the instructions on page 3.
2. Set the M1XSP jumper JP3 to the "232" position. Set MODE jumpers S5=1, S6=1, S7=1, & S8=0 for the Ness C-Bus interface. Set jumper S4=1 if available (not all boards have this jumper). The BAUD jumpers S1,S2, & S3 do not matter as the M1XSP internally presets the baud rate for communicating with the C-Bus interface module.
3. Mount the Ness C-Bus module in a suitable location as recommended by Ness. The M1XSP, operating from the RS-485 data bus, can easily be located away from the control.
4. The Ness C-Bus module is fitted with two RS232 connectors. One DB9 male connector for when connecting to Port 0 on the M1 main serial port and a DB9F female connector for when connecting to the M1 via one of its 7 M1XSP serial modules.

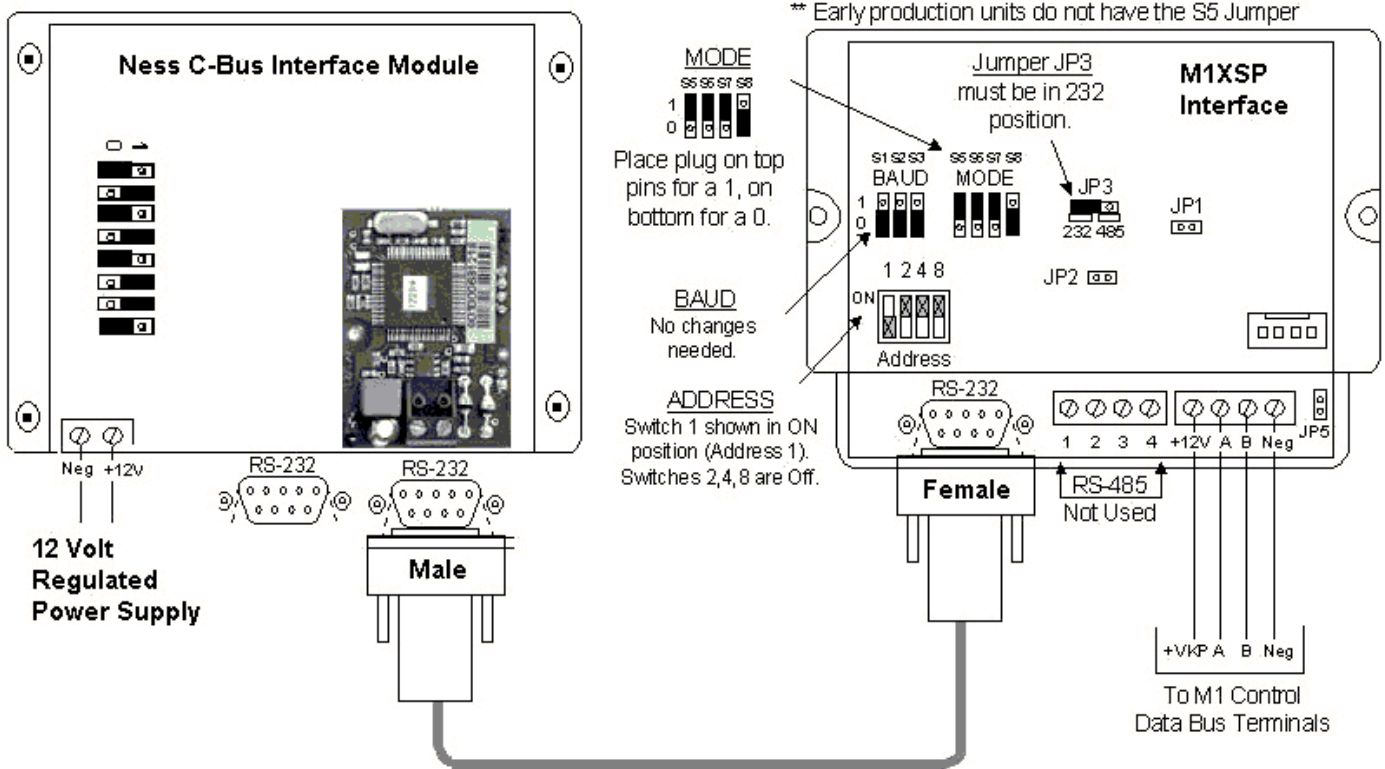

5. Connect a 9-pin serial cable from the Ness M1 C-Bus Interface serial port to the 9 pin connector on the M1XSP.
6. Apply power to the C-Bus Interface and the M1XSP. **DON'T FORGET TO ENROLL THE M1XSP INTO THE M1.**
7. Program and test at least one light device using the NESS-RP Software and the following steps:
8. Click on the Automation icon, then on the Lighting icon.
- 8b. Click on Lighting Device 1 and program the Name (1 to 16 characters), Format = Serial Expander, and Type (switch, dimmer, appliance). The "Show" box may be left blank or checked ("X"). If this box is checked, the light will be included in the scroll list of the Keypad (and Telephone remote) View/Control Automation menus. If not selected for "Show" the light will be available **ONLY** by manually entering the 3 digit light number. Click on the Voice Description (not available in EZ8) to program a 1 to 6 word voice description for this light. Right click on Light 1 and select "Send Lighting 1" to send this programming to the M1.
- 8c. Click on the Rules icon and create the following 2 test rules.

*Test Rule 1: WHENEVER 'Name' (Area 1) IS ARMED AWAY  
THEN TURN 'Name' [1 [A1]] ON*

*Test Rule 2: WHENEVER 'Name' (Area 1) IS DISARMED  
THEN TURN 'Name' [1 [A1]] OFF*

- 8d. Click "Send" to transmit these rules to the M1.
- 8e. Test the manual activation of this light by pressing the "Menu" key on the M1 Keypad followed by the Right arrow key to select "Menu 1-View/Control Automation Fncts". Press 2 for the Lighting submenu, followed by the Right arrow key. The keypad will display the first Light name and number along with its On or Off status. Note: The status will not be correct if the M1 had been powered off. To change the light from On to Off or from Off to On, press the # key.
- 8f. Test the two automation rules by arming the control to the Away mode. The light should come On. Disarming the M1 should cause the light to turn Off.

***[THIS PAGE INTENTIONALLY LEFT BLANK]***

# DYNALITE Interface

Connection to the Dynalite system is achieved via the M1XSP using RS485 format.

This page will describe the installation of the Dynalite system when connecting to the M1XSP module.

1. install the M1XSP per the instructions on page 3.
2. Set the M1XSP jumper JP3 to the "485" position. Set MODE jumpers S5=0, S6=1, S7=0, & S8=1 for Dynalite interface. Set jumper S4=1 if available (not all boards have this jumper). The BAUD jumpers S1,S2, & S3 do not matter as the M1XSP internally presets the baud rate for communicating with the C-Bus interface module.
3. Connection between the M1XSP and the Dynalite network is achieved using a Dynet Power Connection cable as supplied by Dynalite.

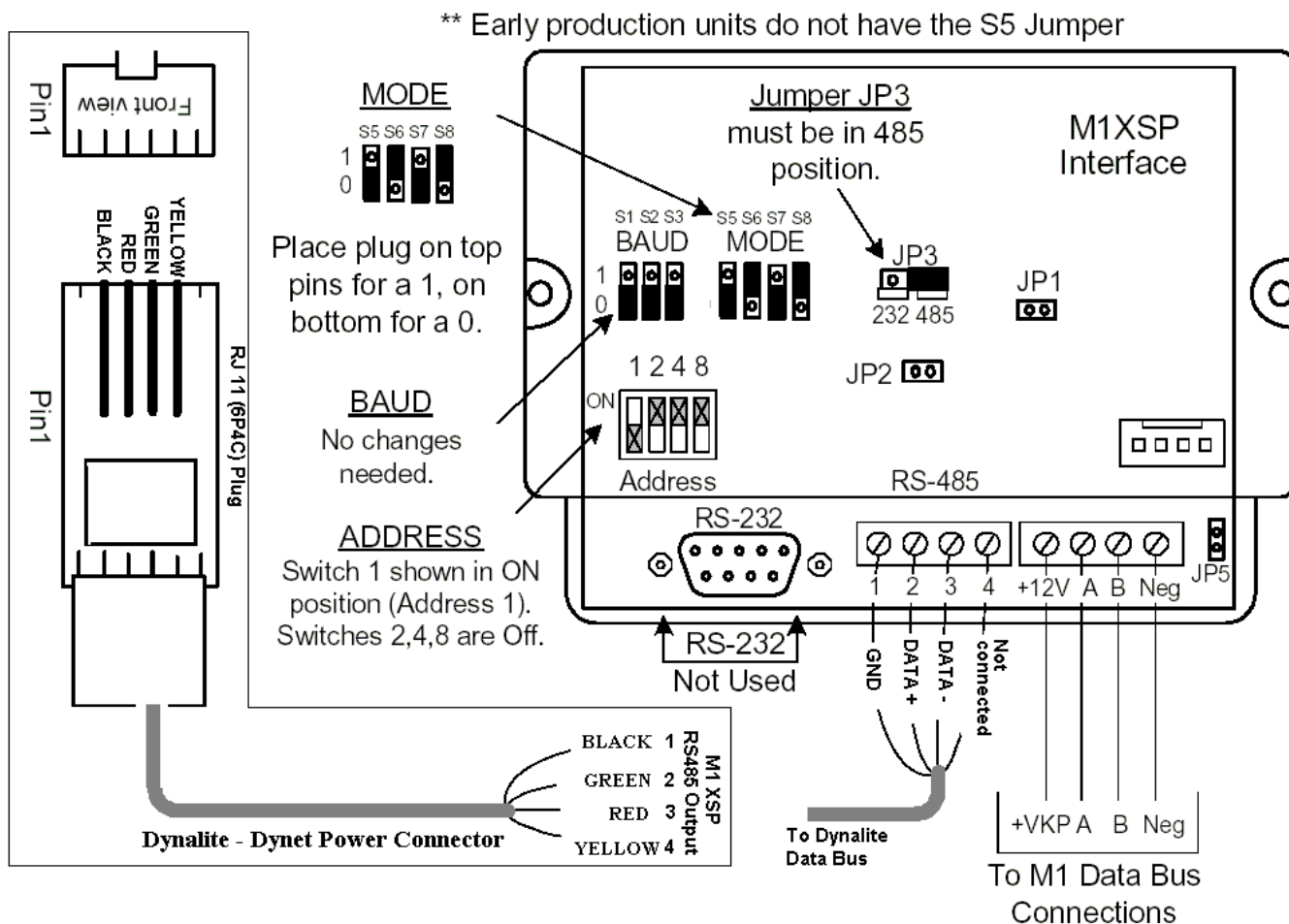

4. Apply power to the M1XSP. DON'T FORGET TO ENROLL THE M1XSP INTO THE M1.
7. Program and test at least one light device using the NESS-RP Software and the following steps:
8. Click on the Automation icon, then on the Lighting icon.
- 8b. Click on Lighting Device 1 and program the Name (1 to 16 characters), Format = Serial Expander, and Type (switch, dimmer, appliance). The "Show" box may be left blank or checked ("X"). If this box is checked, the light will be included in the scroll list of the Keypad (and Telephone remote) View/Control Automation menus. If not selected for "Show" the light will be available ONLY by manually entering the 3 digit light number. Click on the Voice Description (not available in EZ8) to program a 1 to 6 word voice description for this light. Right click on Light 1 and select "Send Lighting 1" to send this programming to the M1.

Ramp Rate on channel control.	
0	=0.1 Sec
1	=0.8 sec
2	= 1.6 sec
3	= 3.3 sec
4	= 5 sec
5	= 6.6 sec
6	= 10 sec
7	= 20 sec

Fade Rate on channel control.	
0	= 2 sec.
1	= 5 sec.
2	= 10 sec.
3	= 30 sec.
4	= 1 min.
5	= 2.30 min.
6	= 5 min.
7	= 10 min.

## DYNALITE Interface Con't

The M1 will support up to 256 Lighting devices. The Dynalite system uses "Areas", "Channels" & "Presets"  
 Within the M1XSP contains pre configured mapping of the 256 lights the M1 supports to Dynalite.

M 1 No.	Dynalite Area	Dynalite Channel	M 1 No.	Dynalite Area	Dynalite Channel	M 1 No.	Dynalite Area	Dynalite Channel	M 1 No.	Dynalite Area	Dynalite Channel
1	Area 1	Channel 1	65	Area 9	Channel 1	129	Area 1	Preset 1	193	Area 13	Preset 5
2	Area 1	Channel 2	66	Area 9	Channel 2	130	Area 1	Preset 2	194	Area 14	Preset 1
3	Area 1	Channel 3	67	Area 9	Channel 3	131	Area 1	Preset 3	195	Area 14	Preset 2
4	Area 1	Channel 4	68	Area 9	Channel 4	132	Area 1	Preset 4	196	Area 14	Preset 3
5	Area 1	Channel 5	69	Area 9	Channel 5	133	Area 1	Preset 5	197	Area 14	Preset 4
6	Area 1	Channel 6	70	Area 9	Channel 6	134	Area 2	Preset 1	198	Area 14	Preset 5
7	Area 1	Channel 7	71	Area 9	Channel 7	135	Area 2	Preset 2	199	Area 15	Preset 1
8	Area 1	Channel 8	72	Area 9	Channel 8	136	Area 2	Preset 3	200	Area 15	Preset 2
9	Area 2	Channel 1	73	Area 10	Channel 1	137	Area 2	Preset 4	201	Area 15	Preset 3
10	Area 2	Channel 2	74	Area 10	Channel 2	138	Area 2	Preset 5	202	Area 15	Preset 4
11	Area 2	Channel 3	75	Area 10	Channel 3	139	Area 3	Preset 1	203	Area 15	Preset 5
12	Area 2	Channel 4	76	Area 10	Channel 4	140	Area 3	Preset 2	204	Area 16	Preset 1
13	Area 2	Channel 5	77	Area 10	Channel 5	141	Area 3	Preset 3	205	Area 16	Preset 2
14	Area 2	Channel 6	78	Area 10	Channel 6	142	Area 3	Preset 4	206	Area 16	Preset 3
15	Area 2	Channel 7	79	Area 10	Channel 7	143	Area 3	Preset 5	207	Area 16	Preset 4
16	Area 2	Channel 8	80	Area 10	Channel 8	144	Area 4	Preset 1	208	Area 16	Preset 5
17	Area 3	Channel 1	81	Area 11	Channel 1	145	Area 4	Preset 2	209	Area 255	Preset 1
18	Area 3	Channel 2	82	Area 11	Channel 2	146	Area 4	Preset 3	210	Area 255	Preset 2
19	Area 3	Channel 3	83	Area 11	Channel 3	147	Area 4	Preset 4	211	Area 255	Preset 3
20	Area 3	Channel 4	84	Area 11	Channel 4	148	Area 4	Preset 5	212	Area 255	Preset 4
21	Area 3	Channel 5	85	Area 11	Channel 5	149	Area 5	Preset 1	213	Area 255	Preset 5
22	Area 3	Channel 6	86	Area 11	Channel 6	150	Area 5	Preset 2	214	Area 255	Preset 6
23	Area 3	Channel 7	87	Area 11	Channel 7	151	Area 5	Preset 3	215	Area 255	Preset 7
24	Area 3	Channel 8	88	Area 11	Channel 8	152	Area 5	Preset 4	216	Area 255	Preset 8
25	Area 4	Channel 1	89	Area 12	Channel 1	153	Area 5	Preset 5	217	Area 255	Preset 9
26	Area 4	Channel 2	90	Area 12	Channel 2	154	Area 6	Preset 1	218	Area 255	Preset 10
27	Area 4	Channel 3	91	Area 12	Channel 3	155	Area 6	Preset 2	219	Area 255	Preset 11
28	Area 4	Channel 4	92	Area 12	Channel 4	156	Area 6	Preset 3	220	Area 255	Preset 12
29	Area 4	Channel 5	93	Area 12	Channel 5	157	Area 6	Preset 4	221	Area 255	Preset 13
30	Area 4	Channel 6	94	Area 12	Channel 6	158	Area 6	Preset 5	222	Area 255	Preset 14
31	Area 4	Channel 7	95	Area 12	Channel 7	159	Area 7	Preset 1	223	Area 255	Preset 15
32	Area 4	Channel 8	96	Area 12	Channel 8	160	Area 7	Preset 2	224	Area 255	Preset 16
33	Area 5	Channel 1	97	Area 13	Channel 1	161	Area 7	Preset 3	225	Area 255	Preset 17
34	Area 5	Channel 2	98	Area 13	Channel 2	162	Area 7	Preset 4	226	Area 255	Preset 18
35	Area 5	Channel 3	99	Area 13	Channel 3	163	Area 7	Preset 5	227	Area 255	Preset 19
36	Area 5	Channel 4	100	Area 13	Channel 4	164	Area 8	Preset 1	228	Area 255	Preset 20
37	Area 5	Channel 5	101	Area 13	Channel 5	165	Area 8	Preset 2	229	Area 255	Preset 21
38	Area 5	Channel 6	102	Area 13	Channel 6	166	Area 8	Preset 3	230	Area 255	Preset 22
39	Area 5	Channel 7	103	Area 13	Channel 7	167	Area 8	Preset 4	231	Area 255	Preset 23
40	Area 5	Channel 8	104	Area 13	Channel 8	168	Area 8	Preset 5	232	Area 255	Preset 24
41	Area 6	Channel 1	105	Area 14	Channel 1	169	Area 9	Preset 1	233	Area 255	Preset 25
42	Area 6	Channel 2	106	Area 14	Channel 2	170	Area 9	Preset 2	234	Area 255	Preset 26
43	Area 6	Channel 3	107	Area 14	Channel 3	171	Area 9	Preset 3	235	Area 255	Preset 27
44	Area 6	Channel 4	108	Area 14	Channel 4	172	Area 9	Preset 4	236	Area 255	Preset 28
45	Area 6	Channel 5	109	Area 14	Channel 5	173	Area 9	Preset 5	237	Area 255	Preset 29
46	Area 6	Channel 6	110	Area 14	Channel 6	174	Area 10	Preset 1	238	Area 255	Preset 30
47	Area 6	Channel 7	111	Area 14	Channel 7	175	Area 10	Preset 2	239	Area 255	Preset 31
48	Area 6	Channel 8	112	Area 14	Channel 8	176	Area 10	Preset 3	240	Area 255	Preset 32
49	Area 7	Channel 1	113	Area 15	Channel 1	177	Area 10	Preset 4	241	Area 255	Preset 33
50	Area 7	Channel 2	114	Area 15	Channel 2	178	Area 10	Preset 5	242	Area 255	Preset 34
51	Area 7	Channel 3	115	Area 15	Channel 3	179	Area 11	Preset 1	243	Area 255	Preset 35
52	Area 7	Channel 4	116	Area 15	Channel 4	180	Area 11	Preset 2	244	Area 255	Preset 36
53	Area 7	Channel 5	117	Area 15	Channel 5	181	Area 11	Preset 3	245	Area 255	Preset 37
54	Area 7	Channel 6	118	Area 15	Channel 6	182	Area 11	Preset 4	246	Area 255	Preset 38
55	Area 7	Channel 7	119	Area 15	Channel 7	183	Area 11	Preset 5	247	Area 255	Preset 39
56	Area 7	Channel 8	120	Area 15	Channel 8	184	Area 12	Preset 1	248	Area 255	Preset 40
57	Area 8	Channel 1	121	Area 16	Channel 1	185	Area 12	Preset 2	249	Area 255	Preset 41
58	Area 8	Channel 2	122	Area 16	Channel 2	186	Area 12	Preset 3	250	Area 255	Preset 42
59	Area 8	Channel 3	123	Area 16	Channel 3	187	Area 12	Preset 4	251	Area 255	Preset 43
60	Area 8	Channel 4	124	Area 16	Channel 4	188	Area 12	Preset 5	252	Area 255	Preset 44
61	Area 8	Channel 5	125	Area 16	Channel 5	189	Area 13	Preset 1	253	Area 255	Preset 45
62	Area 8	Channel 6	126	Area 16	Channel 6	190	Area 13	Preset 2	254	Area 255	Preset 46
63	Area 8	Channel 7	127	Area 16	Channel 7	191	Area 13	Preset 3	255	Area 255	Preset 47
64	Area 8	Channel 8	128	Area 16	Channel 8	192	Area 13	Preset 4	256	Area 256	Preset 48

# Data Bus E.O.L. Termination - VERY IMPORTANT!

The M1 family features a true RS-485 “differential” data bus operating at 38,400 bits per second. This is relatively high speed by industry standards and ensures fast, accurate communications. EOL data bus terminating resistors are required to eliminate the possibility of reflection errors caused by varying cable lengths. Every data bus device; serial port expander, keypad, etc. and the control board has a built-in bus terminating resistor (120 Ohm) which is installed (activated) via a 2 pin header/jumper (2 Gold Pins). The controls hardware pack includes two black shorting caps. When one of the shorting caps is placed on the two gold pins, it installs (activates) the 120 Ohm terminating resistor across Data Lines A & B. Terminating resistors are marked JP2 on the keypads and JP1 on the expanders. From the factory, no terminating resistors are installed (activated).

**WARNING! The RS-485 Data Bus must NEVER have more than 2 terminating resistors header/jumpers installed.**

Ideally, there should be no more than 2 home run cables (4 wire) with daisy chained devices along each. The last device on each cable MUST have a terminating resistor installed (activated) via the gold 2 pin header/jumpers marked JP2 on keypads, JP1 on expanders. Place a black shorting cap (see hardware pack) onto the 2 gold pins to install a 120 Ohm resistor across data lines A & B. If there is only 1 data bus cable place a shorting cap on JP3 of Main Board. See alternate hookups below.

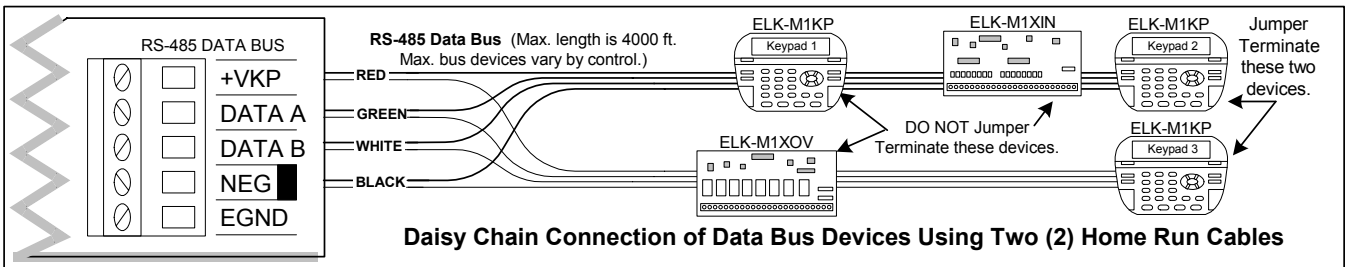

For those that prefer to home run wires, use 6 or 8 conductor (CAT5 is ideal) cable. At each device, make a three way splice of the data A, the device A wire (terminal), and a return data A1 wire (using one of the extra wires). At the control, make a two way splice of the data A1 return wire (series connection) to the outgoing data A wire of the next cable. Repeat for the data B wire. Remember to install a terminating jumper on the last wired device and the control JP3 ONLY! Electrically the data wires are now in series. Connect the POS (+) and Neg (-) power wires of each device directly to the M1's +VKP and Neg terminals. **DO NOT SERIES THE POWER WIRES** as this will cause unnecessary voltage loss.

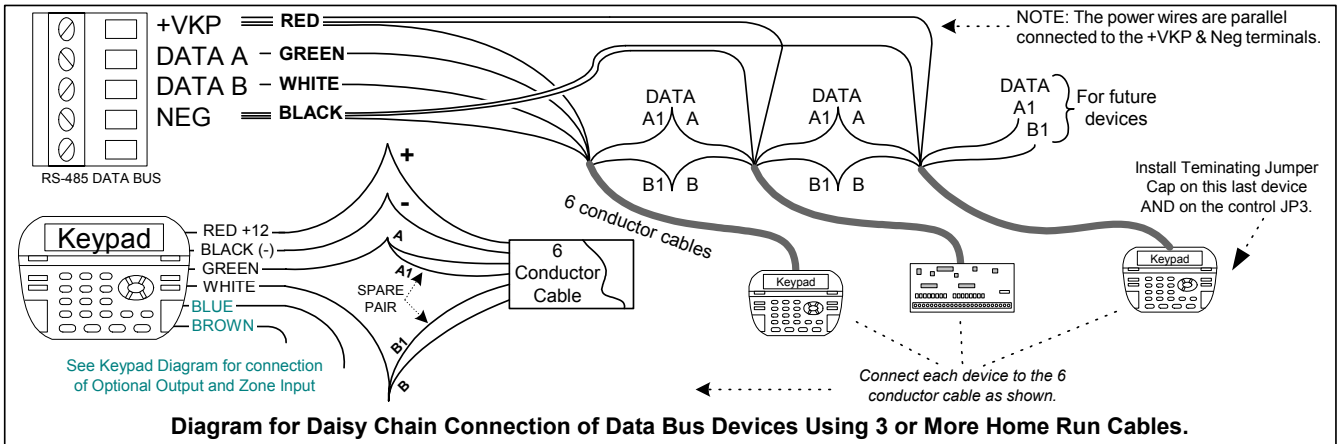

The ELK-M1DBH † Data Bus Hub accepts CAT5 or CAT6 cable with RJ45 plugs on the ends and does all the work of series connecting the DATA lines A & B. Terminate at the hub using the included RJ45 Terminating Plug in the first unused jack.

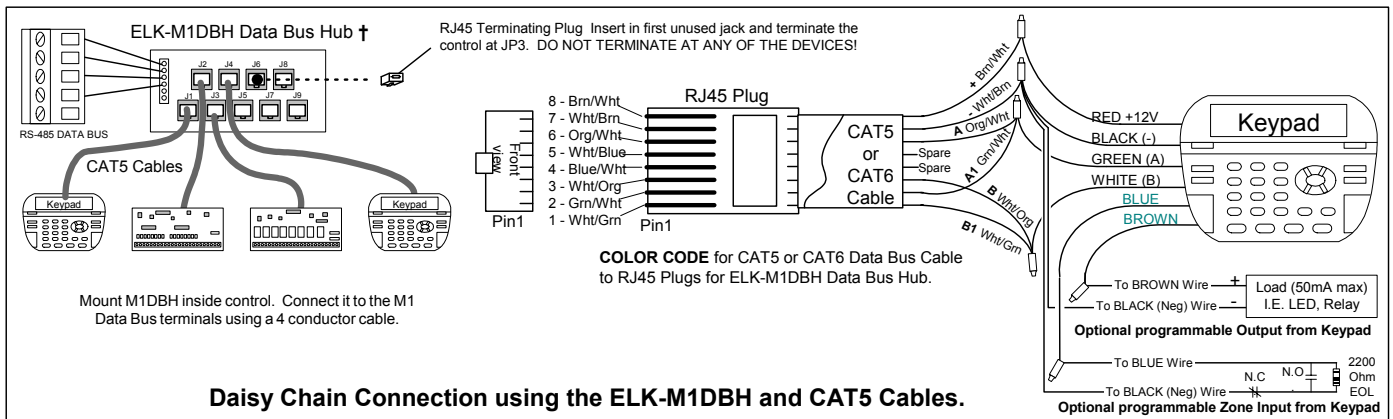

The ELK-M1DBHR † "Active" Data Bus Hub Retrofit splits the Controls' main RS-485 Data Bus into 4 managed RS-485 branches. Each branch can have 2 parallel home run cables for a total of 8 home runs. The last (end of line) device on each home run should be jumper terminated to insure proper operation and supervision.

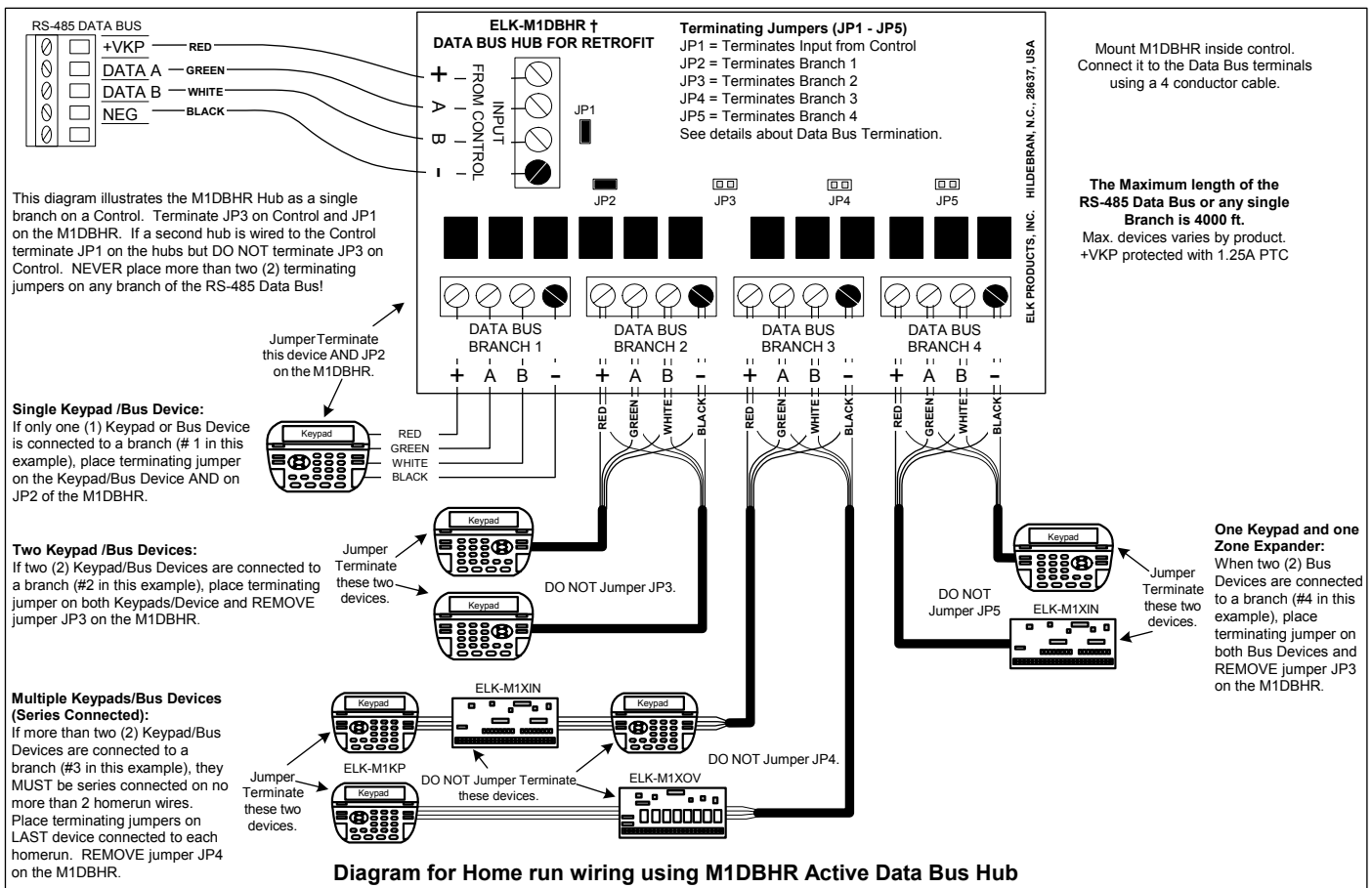

## Setting the Data Bus Address and Enrolling Device(s) into the System

Keypads and expander devices communicate over the RS-485 4-wire data bus. Each device must have a unique address setting (from 1 to 16) within its device type. Keypads are TYPE 1, input (zone) expanders TYPE 2, output expanders TYPE 3, serial expanders TYPE 4, etc. The purpose of device types is so that the address numbers can be re-used in each different device type. It's OK to have a Keypad, Zone Expander, and Output Expander all set to address 2 and on the same data bus since each device is a different device type. **It is NOT OK to have duplications of addresses within the same device type. I.E. Multiple keypads on the same control cannot be set to 'like' addresses.**

**ADDRESS:** From the factory all keypads are set to address 1. Valid addresses are 1 to 16. The first keypad on the system (Keypad 1) is automatically enrolled upon power up. Each additional keypad must be assigned a unique address and then manually enrolled from "Menu 1 - Bus Module Enrollment". (See Menu 01, for complete instructions on Bus Module Enrollment)

1. Press and hold the " \* " key, followed by the F5 key . HOLD BOTH keys pressed for 5-10 seconds or until the LCD displays:

**Exit when done. F1 Set Addr.** (This is Keypad setup mode)

NOTE: An alternate method is to remove power from the keypad and then power up while holding any key pressed.

2. Press the F1 key to display the current address setting.
3. Set the desired address (from 1 to 16) by using the Up or Down arrow keys.
4. Press the Exit key twice when done.

### ENROLLING:

1. Press the ELK key, then 9 (or scroll up) to display 9 - Installation Programming. Press the RIGHT arrow key to select this menu. The Installer Program Code must be entered to access this menu.
2. Enter the Installer Program Code. (The default code is 172839)
3. The first Installer Programming menu displayed will be "Bus Module Enrollment"
4. Press the RIGHT arrow key to select this menu. "Enrolling Bus Modules" will display
5. After a few seconds the display will show the total Bus Modules that are enrolled. To view the enrolled devices and/or remove a device press the RIGHT arrow key next to the word Edit.
6. Press the \* or Exit keys to exit Installer Programming.

**Auth. Required  
Enter Valid Pin**

**01-Bus Module  
Enrollment**

**XX Bus Modules  
Enrolled, Edit ▶**

# M1XSP Compatibility, Jumper Settings and Misc.

The M1XSP options are selected by the placement of black shorting plugs onto gold plated jumper pins. Some jumpers have 3 pins with a selection of "0" or "1". Some Jumpers have only 2 pins with a selection of Off or On. Options vary by manufacturer. See detailed installation and hookup diagrams and the tables below to select options.

MODE Jumpers	Jumper Settings ** (S4 for future use)					Special setup, notes, and comments	BAUD Rate (Preset Speed)
	S4	S5	S6	S7	S8		
Serial Port Exp.	-	1	0	0	0	BAUD Jumpers must be set to desired speed.	Select from Chart
RCS Thermostat	-	1	0	0	1	Set JP3 to 232 or 485 depending on RCS model	(9,600)
HAI Thermostat	-	1	0	1	0	JP5 must be "ON" for this mode.	(300)
Aprilaire Thermostat	-	1	0	1	1		(9,600)
OnQ-ALC	-	1	1	0	0		(9,600)
PCS-UPB	-	1	1	0	1	JP5 must to "ON" for this Mode	(4,800)
Centralite	-	1	1	1	0		(19,200)
EDT- iLine	-	1	1	1	1		(9,600)
Uplink Radio	-	0	0	0	0		(9,600)
[future]	-	0	0	0	1		
[future]	-	0	0	1	0		
Clipsal C-Bus	-	1	1	1	0		(19,200)
Dynalite	-	0	1	0	1		(9,600)
[future]	-	0	1	0	1		
Lutron Radio RA	-	0	1	1	0		
[future]	-	0	1	1	1		

\*\* Jumper S4 is for future expansion use and is shown for reference purposes only. Current production M1XSPs do not provide this jumper. Jumper J5 was not provided on very early production units. The equivalent value of position J5 with no jumper is a 1.

**THE ABOVE CHART REPRESENTS COMPATIBILITY AS OF FIRMWARE VER. 1.1.11**

**NOTE: BAUD Rate Jumpers are only required to be set when the M1XSP is configured as a "Serial Port Expander". Each of the Mfg. specific settings have the BAUD Rate Speed internally preset. Refer to MODE Jumpers above.**

BAUD Rate	Jumper Settings		
	S1	S2	S3
110	0	0	0
300	1	0	0
1200	0	1	0
2400	1	1	0
4800	0	0	1
9600	1	0	1
19,200	0	1	1
38,400	1	1	1

### Other Jumper Settings

- JP1 Used to engage a 120 Ohm resistor for terminating the M1 RS-485 Data Bus. See M1 Data bus wiring instructions before use.
- JP2 Used to engage a 120 Ohm resistor for terminating the 'Outbound' (External) RS-485 Data Bus if required by other manufacturer.
- JP3 Selects either RS-232 or RS-485 format communications on the 'Outbound' connections. Jumper Left = RS-232, Jumper Right = RS-485
- JP4 Not used
- JP5 Used to supply +12V to pin 4 (DTR) of the DB9 Female connector for certain modes. This jumper can be left on always.

## THERMOSTAT COMPATIBILITY CHART

Brand & Model	Format	Baud Rate	Maximum Thermostats		Required Number of M1XSP and Other Equipment
			M1G / M1EZ8	M1 (Std)	
RCS TR-16	RS-485	Auto 9600	16	2	1 M1XSP handles all thermostats
RCS TR-40	RS-485	Auto 9600	16	2	1 M1XSP handles all thermostats
RCS TR-16	RS-232	Auto 9600	7	1	RCS 232 format requires 1 M1XSP per Thermostat
Aprilaire 8870	RS-485	Auto 9600	16	2	1 M1XSP + 8811 Adapter & 8818 Dist. Panel required
HAI RC Series	RS-232	Auto 300	16	2	1 M1XSP for every 4 thermostats **

**\*\* IMPORTANT: When interfacing with HAI Thermostats, address switches on the M1XSP may ONLY be set to 1, 2, 3, or 4. Address 1 talks with HAI Thermostats addressed as 1 thru 4. Address 2 talks with HAI Thermostats addressed as 5 to 8. Address 3 talks with HAI Thermostats addressed as 9 to 12. Address 4 talks with HAI Thermostats addressed as 13 to 16.**

### WO37A Cable Pin-out and Wire Color Coding

DB9F female Connector Wire Color  
 Pin 2 connects to ..... RED  
 Pin 3 connects to ..... GREEN  
 Pin 4 connects to ..... WHITE (YELLOW)  
 Pin 5 connects to ..... BLACK  
 Pins 1, 4, and 6 (DCD, DTR, and DSR) jump together.  
 Pins 7 & 8 (RTS and CTS) jump together.

### 9 Pin Serial (DB9M male to DB9F female) Cable The M1 requires only 3 wires to be connected:

Connector	Wire Color	Connector
DB9M male		DB9F female
Pin 2 connects to .....	N/A	Pin 2
Pin 3 connects to .....	N/A	Pin 3
Pin 5 connects to .....	N/A	Pin 5