

# INSTALLATION NOTES



## NESS SCR SINGLE CHANNEL RECEIVER

---

**PART NUMBER:** 100-187

**MODEL:** SCR Single Channel Receiver

---



NESS SECURITY PRODUCTS  
Australian Communications Authority  
RADIO COMMUNICATIONS COMPLIANCE



## INTRODUCTION

The Ness Standalone Wireless Receiver is a unique high performance 303.875Mhz radio receiver designed to operate in conjunction with any Ness proprietary Radio Transmitting device including Ness 3 Button Radio Pendants, Wrist watch panic buttons, Radio Reed switches and Radio PIR.

The Standalone Receiver is ideal for connecting to Alarm panels which do not provide a wireless facility and can be used for connecting, Wireless devices for zone alarms, Panic buttons or Radio Keys for Arming and Disarming the Panel. The Control input on the Standalone Receiver gives it the unique ability to identify the Armed/Disarmed status of an Alarm panel and when used with a 3 button Pendant it allows the Receiver to always correctly Arm or Disarm the Panel, unlike similar receivers with a single button and toggling output which can place the Panel in the wrong state without the user realising the error.

The Standalone Receiver is also ideally suited for applications which require a Remotely switched Relay output for power switching applications e.g. Garage door opening.

The Standalone Receiver comes complete with separate Arm/Disarmed or Alarm Dry contact Relay output, Panic output and Low battery output . The Relay output can be selected to be Pulsing or Latched to suit your application. The Standalone Receiver will accept up to four individual Radio Keys and Panic Buttons or up to four alarm transmitting devices (Reed switches or PIRs).

## PROGRAMMING

The Ness Standalone Receiver can be programmed with up to four similar Ness transmitting devices i.e. either Radio Key devices (Panic buttons, On/Off keys) or Alarm transmitting devices i.e. Reed Switches or Radio PIR's.

Note - You cannot mix Alarm devices with Key type devices, the receiver will only accept one type.

The Standalone Receiver will learn the Radio code of the device to be programmed and the code will be stored in non-volatile memory. The Standalone Receiver will also allow the code to be overwritten if required or erased totally, this is fully described later in this manual.

## PROGRAMMING STEPS

1. Select a Radio device to be programmed into the Standalone Receiver and place a link on the Code number you wish it to be allocated to (Code 1 to Code 4 Links M1 to M2) .

The LED will change from a slow flash to either;

- a) A faster flash indicating that the Code slot is not yet programmed with any device. or,
- b) Turn on steady indicating that there is already a device programmed into that slot.

2. Make the device to be programmed into the Standalone Receiver transmit 3 times, to achieve this do the following;

- For a Radio Key Press the "OFF" Button 3 times.

- For a RK1 Radio Pendant press the Panic button 3 times ( be aware of the 1.5 second delay on the button press).

- For a PIR you will need to place the PIR in Test Mode and trigger an alarm 3 times.

- For a Reed Switch you will need to trigger an Alarm by moving the magnet away from the Reed Switch then a Restore Alarm by moving the Magnet back and finally another Alarm by moving the magnet away.

3. You should notice that the LED will do the following;

- Turn off on the first code received.
- Blink once quickly on the second code received.
- Turn on steady on the third code received indicating the code has been accepted and programmed into memory.

4. To program more devices repeat steps 1 to 3 otherwise remove the program link and park it on a single Pin for future use.

5. Once the Program Link is removed the LED should flash slowly indicating normal operation.

*NOTE - Code 1 will always come factory programmed with a Radio Key for test purposes only.*

## TO ERASE A CODE

If you wish to clear an already programmed Device carry out the following steps, otherwise if you simply wish to over-write a device with a new one then carry out the steps described in Programming Steps above.

1. Place the Program Link onto the number of the Device you wish to clear (Code 1 to code 4)
2. The LED should be on steady indicating that the slot has a device programmed into it.
3. Using any standard Ness Radio Key press the "ON" Button once.
4. The LED should change from being on steady to a fast flash indicating that the device has been erased and that the slot is now clear.
5. Remove the Program link and park it on a single pin for future use.

## OPTIONS

INPUT - The input serves as an inhibit for the Relay output depending on the state of the input. Applying less than 1 Volt to this input makes it "LOW" and applying greater than 4 Volts or leaving this input open makes this input "HIGH". The inhibit feature is only functional when Momentary action is selected, this is more fully described below.

For a summary of the action of this feature see the table on the next page.

LATCH/MOMENTARY LINK LK1- The Relay can be selected to either Toggle on Key button presses or Pulse for 2 seconds when a valid code is received.

Link On = Latching operation

Link Off = Momentary operation

## OPTIONS - LATCHING

Link set to LATCH. (Only use with Radio Keys and reed switches ). *Inhibit Input has no effect.*

**Application 1. Relay Turns On and Off using a Radio Key.**

Pressing the "ON" button on a Ness Radio Key will turn the Relay on. Further presses of the "ON" button when the relay is on will have no affect.

Pressing the "OFF" button on Ness Radio Key will turn the Relay off. Further presses of the "OFF" button when the Relay is off will have no affect.

**Application 2. Relay follows the state of the Reed Switch.**

When a single Reed switch alarms the Relay will turn ON. When the Reed Switch restores the Relay will turn OFF.

If more than one Reed switch is programmed then the Relay will turn ON when any Reed Switch alarms but will only turn OFF when all Reed Switches have restored

## OPTIONS - MOMENTARY

Link set to Momentary ( Can be used with Radio Keys or Alarm Devices)

### **Application 1. PIRs and Reed Switch used in normal alarm operation.**

Use this application if you simply wish to add alarm device to your control panel.

For Alarm Devices with the Inhibit input "High" or left open.

The Relay will pulse on for 2 seconds every time a valid code is received from any of the programmed devices (PIR or Reed Switch) when they Alarm.

### **Application 2. PIRs and Reed Switches Alarm operation with Inhibit.**

Use this special application if you need to inhibit the alarm relay at certain times

For Alarm Devices with the Inhibit input switching between "High" and "Low" (less than 1 Volt)

Whilst the Input is "High" the Relay will pulse on for 2 seconds every time a valid code is received from any of the programmed devices (PIR or Reed Switches) when they alarm.

When the Input is changed to "Low" then all Alarms will be ignored from the programmed devices.

Only use this feature if you specifically wish to ignore alarms from devices.

### **Application 3. Radio Key Simple Pulsing Relay output.**

Use this application if you want a simple pulsing output with a Radio Key. Only the "ON" button on the Radio Key will pulse the Relay.

For Radio Keys with the Inhibit input "High" or left open.

Every time the "ON" button is pressed on the Radio Key the Relay will pulse, pressing the "OFF" button whilst the Inhibit is "High" will not pulse the relay.

### **Application 4. Control Panel Arming using an Armed/Disarmed output from the Panel.**

Use this application for correctly Arming and Disarming a Control Panel using the ON and OFF buttons on a Radio Key as long as there is an Armed/Disarmed Output from the Control panel which can be wired into the Inhibit Input on the Standalone Receiver.

When the Panel is Armed the Inhibit Input will require a "LOW" or less than 1 Volt and when the Panel is Disarmed the Inhibit Input will require a "HIGH" or greater than 4 Volts. When wired correctly the Relay output will do the following;

With the Panel Disarmed (Inhibit Input "High") pressing the "OFF" button will have no effect, pressing the "ON" button will pulse the Relay output which can be used to Arm the Control Panel.

With the Control Panel Armed ( Inhibit Input "Low") pressing the "ON" button will have no effect, pressing the "OFF" button will pulse the Relay which can be used to Disarm the Control Panel.

## TABLE - OUTPUT OPERATION

ACTION	LINK	INPUT	RELAY
3 button Key or Reed Switch	Latching	Input Ignored	Toggle
Device Alarm, PIR or Reed	Momentary	Low < 1V	No Change
Device Alarm, PIR or Reed	Momentary	High > 4V	Pulse
Key "ON"	Momentary	Low < 1V	No Change
Key "ON"	Momentary	High > 4V	Pulse
Key "OFF"	Momentary	Low < 1V	Pulse
Key " OFF"	Momentary	High > 4V	No Change

### OUTPUTS

**RELAY** - The relay output is a single pole changeover dry contact rated at 1amp @ 28 Volts. The Relay output is used to provide either Alarm output or Arm/Disarm output. The function is more fully described above.

**PANIC/TAMPER** - The Panic/Tamper output is an open collector (switched low) output rated at 20 mA. The Panic/Tamper output will pulse for 2 seconds every time that either;

- a) A panic Button is pressed on a 3 Button Radio Key or a Wrist watch button is activated or,
- b) A Tamper Alarm is generated on a Radio PIR or a Reed Switch.

*Note - The Momentary/Latch Link has no affect on the operation of the Panic/Tamper output.*

**LOW BATTERY** - The Low Battery output is an open collector (switched low) output rated at 20mA. The Low Battery output will pulse for 2 seconds every time that it receives a Low battery signal from either a Radio Key or an Alarm Device and should only be used as a warning that batteries require changing.

*Note - The Standalone receiver provides no means of identifying which Key or Device has caused the Low Battery alarm however all Ness Keys and Alarm Devices display Low Battery by flashing their LED instead of turning it on steady when they are transmitting.*

### NORMAL OPERATION

The Standalone receiver requires a DC regulated supply from 10 - 14 Volts to operate correctly.

When operating normally the LED on the Standalone Receiver will flash slowly. Whenever a valid Radio transmission is received the LED will Turn on for 2 seconds. Always ensure that the Receiver is kept well away from potential interference devices i.e. Televisions, Video's, Computers, if you are experiencing problems move the Receiver well away from other devices then connect with a battery only and re-test to attempt to isolate the cause of the problem.

Always keep the antenna J1 well away from your control panel and wiring and potential Radio Interference devices. The antennae should be kept straight and not coiled up tightly or tied into a knot. NEVER SHORTEN OR LENGTHEN THE ANTENNA AS IT IS A CRITICALLY TUNED LENGTH.

For details on the connection of external antenna contact your nearest Ness Security Sales Branch.

# WIRING SCR TO L8 PANEL

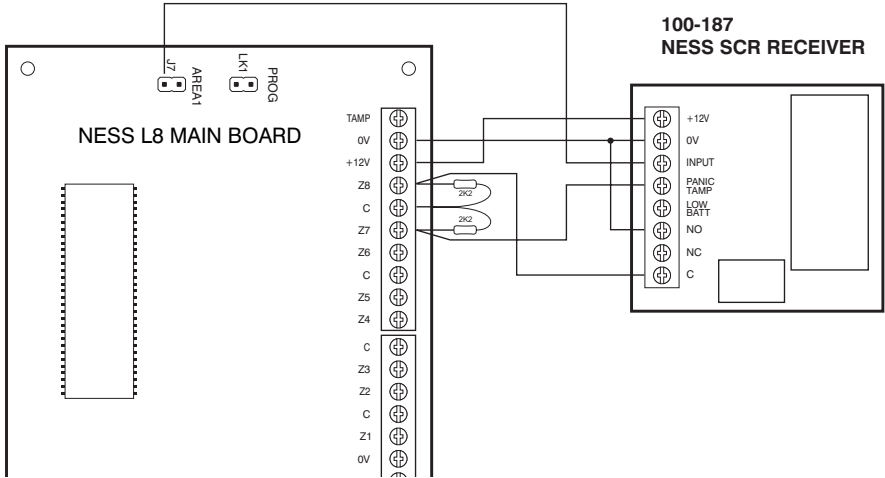

# WIRING SCR TO PRO-LD PANEL

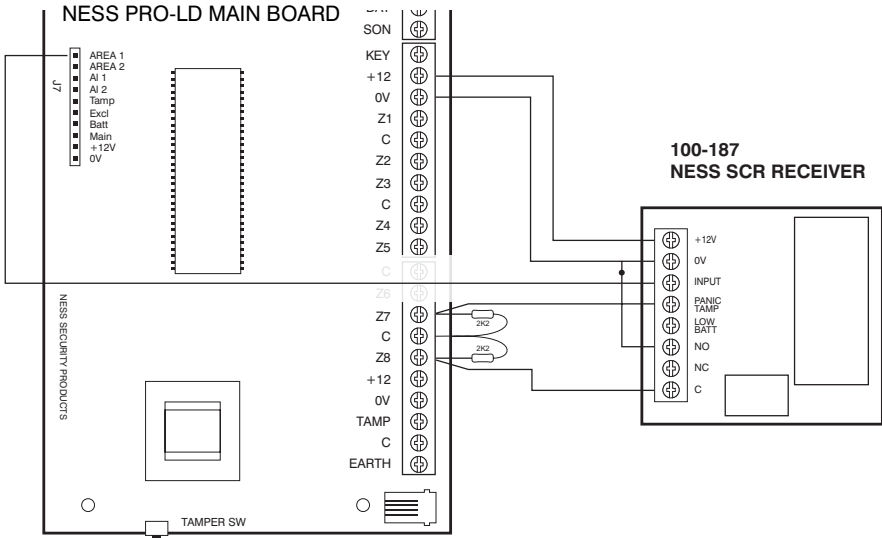

# WIRING SCR TO PRO-LX PANEL

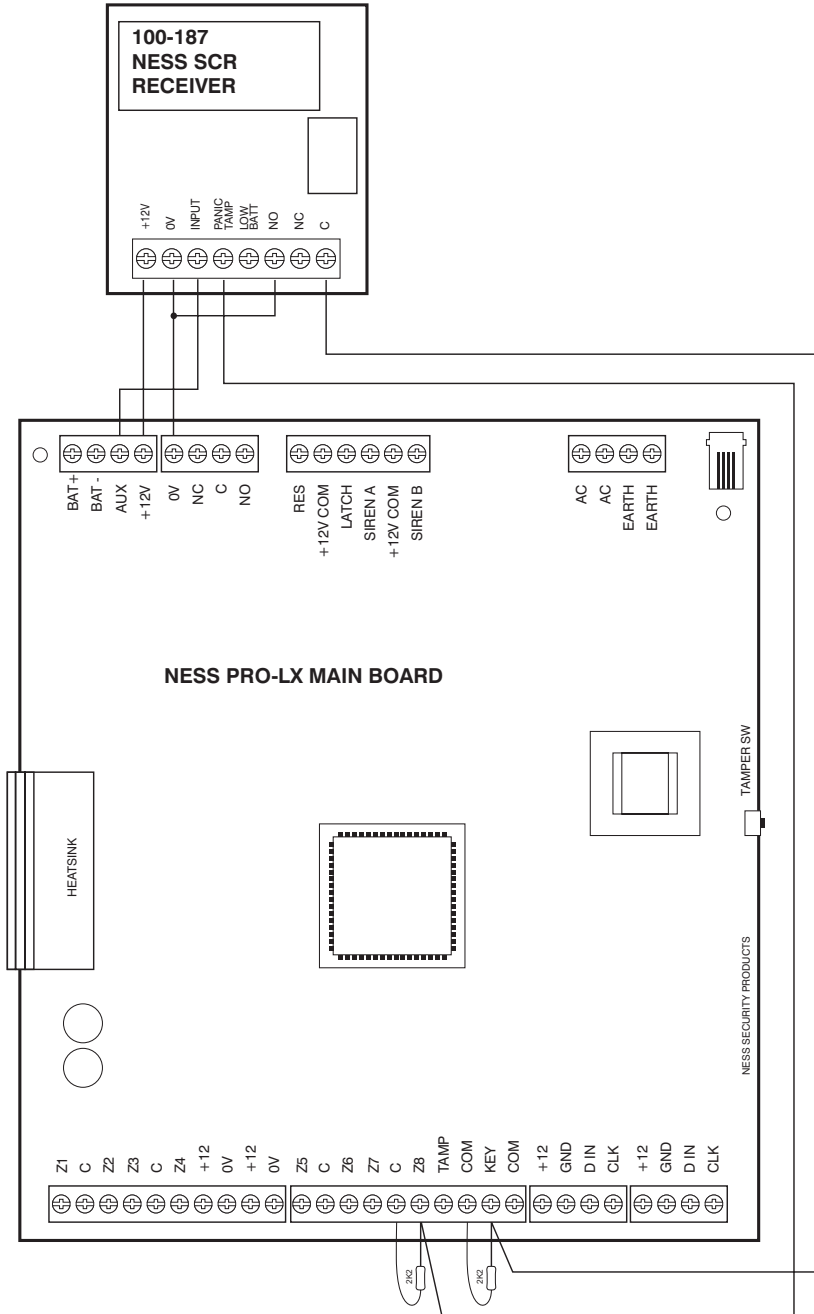

## SPECIFICATIONS

Dimensions..... 78(h) x 73(w) x 27(d) mm.  
Operating voltage ..... 10–15V DC  
Standby current draw .... 15mA  
Radio frequency ..... 303.85MHz  
Low Voltage Output..... 20mA @ 12V  
Panic/Tamper Output..... 20mA @ 12V  
Relay Output ..... Dry contact rated 1A @ 28V  
Max. radio devices ..... 4



NESS SECURITY PRODUCTS  
Australian Communications Authority  
RADIO COMMUNICATIONS COMPLIANCE



*Security Products*



NESS SCR RECEIVER  
INSTALLATION NOTES

Document part number: 890-129  
For products: 100-187 Ness SCR Receiver

© 2003 Ness Security Products Pty Ltd ABN 28 069 984 372

Specifications may change without notice.