

Installation Notes



NESS RADIO DIALLER

Part No. 100-284

Hybrid Wireless/Landline dialler for Ness SecurityGuard systems

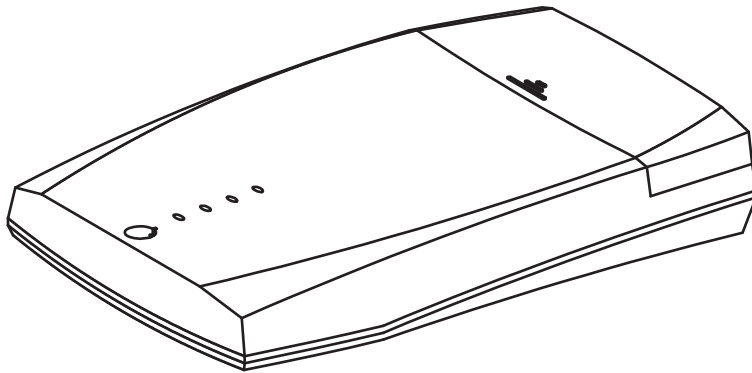

FEATURES

- Supervised radio link to SecurityGuard
- Onboard backup battery
- Mains Fail supervision and warning
- Low Battery / Battery Missing / Battery Capacity tests and warning
- Telephone Line supervision
- Fast & easy installation
- No special tools required
- Compatible with SecurityGuard II & III

Introduction

The Ness Radio Dialler is a unique hybrid wireless/landline dialler which provides back-to-base monitoring capability for Ness SecurityGuard products without the need for additional telephone cabling.

The Ness Radio Dialler establishes a wireless link with a SecurityGuard and then sends the alarm data via a telephone landline. The Ness SecurityGuard III (SGIII) has the required radio interface built-in, whilst the SecurityGuard II (SGII) can easily be retrofitted with the optional radio interface.

The Ness Radio Dialler is designed to easily plug into an existing telephone wall socket and does not need to be installed by a licensed telecommunications cabler.

The result is full back-to-base monitoring capability for the Ness SecurityGuard with minimal installation and no extra cabling.

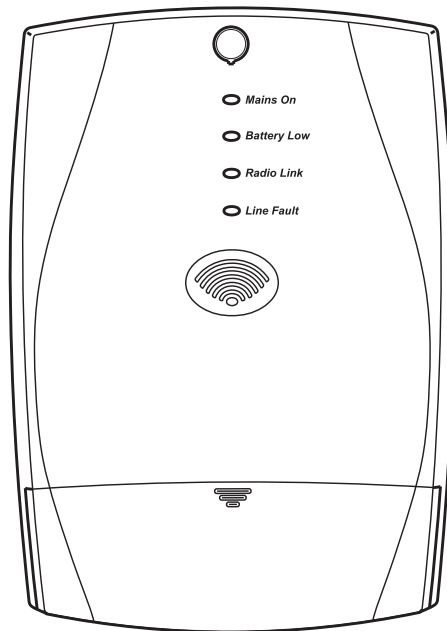

Telephone connection

The Ness Radio Dialler should be connects to an existing telephone wall socket, preferably the first incoming telephone socket.

The existing telephone's lead connects to the Radio Dialler's LINE socket and the supplied telephone cable is used to connect the Radio Dialler to the existing telephone.

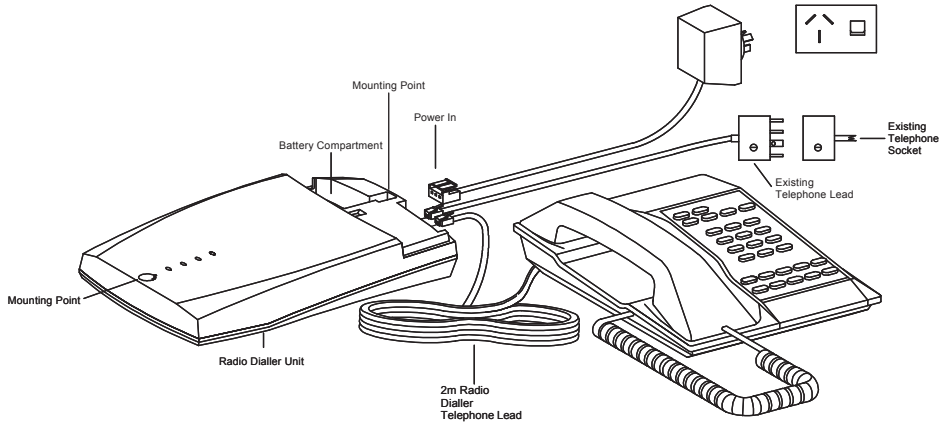

FIG1. Connection Diagram Australia.

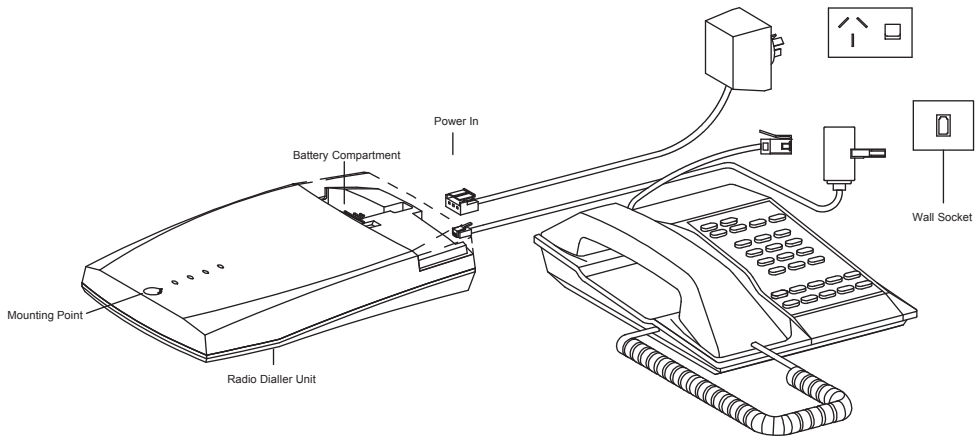

FIG2. Connection Diagram New Zealand.

Programming & Setup (SGIII)

“OneShot” Programming downloads programming data from the SGIII to the Radio Dialler and ensures security by “locking in” the telephone numbers 30 days after initial programming.

The installer is able to change the telephone numbers as required only during the 30 day timer period. All other programming options can be changed at any time.

When the One-Shot timer has expired, the Radio Dialler can only be re-programmed using the Radio Dialler Upload/Download software, (See, Remote Programming).

SGIII programming

The central station telephone numbers and client account numbers are programming into the SGIII. These numbers will be downloaded to the Radio Interface at step 8 of the setup process.

1. Program the following extra options into the SecurityGuard.
 - Telephone Number (phone1)
 - Telephone Number (phone2 optional)
 - Client Account Number (client)
2. Once programming is completed leave the SecurityGuard III in program mode.

Radio Dialler setup & connections

3. Mount the Radio Dialler securely to a wall with screws or surface within reach of a mains outlet and telephone socket.

NOTE: the preferred location for the Radio Dialler is at the first incoming telephone socket from the street. This will ensure that the dialler has priority when it needs to send a message to the central station.

4. Unplug the incoming line cable from the existing telephone and plug it into the Radio Dialler’s LINE socket. (See FIG1).
5. Connect the supplied telephone cable to the Radio Dialler’s TELEPHONE socket and the existing telephone’s LINE socket.
- 6a. Connect the AC adaptor lead into the power socket on the rear of the Radio Dialler. Plug the AC adaptor into a mains outlet and turn mains power on.
- 6b. Connect the backup battery to the battery socket inside the battery well.

7. On power-up, the indicator lights will briefly flash out the software version number.

The MAINS ON light will be on and the RADIO LINK light will double-flash. The Radio Dialler is now in program mode and will remain so for 2 minutes or until it receives the ‘Learn’ signal from the SecurityGuard.

Sending the SGIII ‘Learn’ signal

8. Before the Radio Dialler exits (4min) out of program mode, press the ON button of one of the SGIII radio keys.

The SGIII will exit program mode and automatically upload the ‘Learn’ signal to the Radio Dialler. (The Learn signal includes the central station telephone numbers and account number which were programmed at Step 1).

Verifying Radio Dialler programming

9. The RADIO LINK light will turn on for about five seconds to indicate that the Radio Dialler has successfully downloaded the ‘Learn’ signal from the SecurityGuard.

Once the download is completed, the Radio Dialler will beep the signal strength (1-9) of the ‘Learn’ signal and the four front panel lights will display the radio signal strength. The four lights form a bar graph as follows:

	SIGNAL STRENGTH			
	1-2	3-4	5-6	7-9
Mains On				ON
Battery Low			ON	ON
Radio Link		ON	ON	ON
Line Fault	ON	ON	ON	ON

The more LEDs on, the greater the signal strength.

Front Panel Indicators

The front panel indicators (LEDs) are used to indicate the status of various Radio Dialler conditions.

Mains On

ON: Mains is ok

FLASHING: Mains has been off for at least one hour.

If mains failure persists for more than one hour, a MAINS FAIL alarm is reported to the central station. When the mains power is restored, a MAINS FAIL restore is reported to the central station (only if MAINS FAIL has been reported). The dialler will beep five times every hour only if there is a line or a dialler fault that will restrict the alarm from being reported.

Battery Low

ON: If a backup battery is not connected the dialler will continuously beep until a battery is fitted. A LOW BATTERY alarm will be reported to the central station only if the battery has been missing for more than 60 seconds. This time delay allows battery replacement without sending a low battery report.

FLASHING, Single Flash: The backup battery has discharged to below 25% capacity. The battery should be replaced.

A LOW BATTERY alarm will be reported to the central station. A LOW BATTERY RESTORE will be reported when the battery has recharged to approx.. 75% capacity.

FLASHING, Double Flash: The backup battery cannot be charged or cannot hold a charge.

The battery should be replaced.

Radio Link

ON: Receiving a valid programming message such as the Learn message from an SGIII.

FLASHING, Slowly: Dialler is not programmed.

FLASHING, Fast: In Program Mode indicates that the dialler is already programmed.

Line Fault

OFF: Normal condition.

ON: Dialler is currently sending a message.

FLASHING, Single Flash: Telephone line failure. The telephone has been disconnected. The Radio Dialler tests the line every 30 seconds.

If during this time a Low Battery fault or Mains fault occurs, the Radio Dialler will beep five times every hour. This condition will clear with a successful subsequent dialout.

FLASHING, Double Flash: Comms Failure. A report to the central station has failed. If during this time a Low Battery fault or Mains fault occurs, the Radio Dialler will beep five times every hour. This condition will clear with a successful subsequent dialout.

Listen-in Mode

INSTALLER'S DIAGNOSTICS.

Apply a shorting link to J6 to enable Listen-in mode.

All dialler activity will be heard via the onboard piezo sounder.



Place a shorting link on J6 to enable Listen-in Mode.

Dialling Method

The Radio Dialler auto-detects the dial tone and dials in DTMF or Rotary as determined by the dial tone.

In cases where the dial tone is undetectable or non-standard (such a stutter-tone) the Radio Dialler can be forced to dial in DTMF always.

Place a shorting link across pins 2 & 3 of the J7 header on the main board to force DTMF dialling.



Place a shorting link on pins 2 & 3 of J7 to force DTMF dialling.

Test Calls

SecurityGuard II: Test calls are sent weekly to the central station. The time interval is fixed. The first test call is sent 14 hours after leaving program mode or after powering up the Radio Dialler.

SecurityGuard III: Test calls can be programmed in intervals 1 day, 7days, 14 days, 30 days or OFF.

Radio PIR Supervision

Supervised Detector (380) sensor trouble message including the device number is sent the SGIII fails to see 24 consecutive polls from the device. The restore will be sent when the device a poll message or is next triggered.

SecurityGuard Supervision

The integrity of the radio link between the SecurityGuard and the Radio Dialler is tested by a supervision poll sent by the SecurityGuard every 90 minutes.

If the radio dialler fails to receive eight consecutive poll messages it will send a Radio Jamming alarm to the central station (Contact ID 355-105).

A Restore message is sent when the Radio dialler receives the next valid poll.

Remote Programming

The Radio Dialler can be programmed remotely via PC and Ness Upload/Download software.

Remote programming can used either to:

a/ Reset the One Shot programming option allowing the technician to reprogram the Radio Dialler via the SecurityGuard.

b/ Or the phone1, phone2 and client numbers can be remotely downloaded to the Radio Dialler. Note, in this case, the numbers programmed in the SecurityGuard may be different to the Radio Dialler.

REMOTE PROGRAMMING

1. Ensure Radio Dialler is powered up.
2. Power up SGIII and press OFF to enter PROGRAM mode. Radio Dialler will now be ready to answer incoming calls for the next 5 minutes. If the Dialler answers a call but does not verify within 30 seconds it will hang-up. Once a connection is established, the Dialler will unconditionally hang-up after 5 minutes if a hang-up is not requested sooner by the remote end.
3. Once a connection is established, program the SGIII/Radio Dialler system as required.

SGIII will exit PROGRAM mode when the Up/down connection is terminated, or when the SGIII PROGRAM mode timer expires, whichever occurs first. If PHONE1 has been programmed, then if data transfer to Radio Dialler has not been successful within a short period, SGIII will raise a system alarm indicating radio link failure with the Dialler.

Contact ID Reporting Codes

MESSAGE FORM

The Contact ID message is reported in the following format:

SSSS 18 Q XYZ GG CCC E

SSSS 4 digit Client Account number

18 Uniquely identifies this format as Contact ID

Q Event qualifier (1 = New alarm or Open; 3 = Restore or Close)

XYZ Event code (hexadecimal)

GG Group code. (always 00)

CCC Sensor/key ID + offset, or Type number (decimal)

E Error check

Report Name	SGII		SGIII	
	XYZ	CCC	XYZ	CCC
Burglary by device	130	001-050	130	001-050
24hr by device	133	051-100	133	051-100
Siren box tamper	137	106	137	106
Sensor tamper by device	383	352-400	383	352-400
Panic by user	120	301-350	120	301-350
Duress by user	121	401-450	121	401-450
Medical Pendant	100	651-700	101	651-700
Radio Jamming	355	105	355	105
Radio Device Supervision Poll Fail (Detectors)	355	202-250	355	202-250
Radio Device Supervision Poll Fail (Fixed Panic Button)	355	501-600	355	501-600
Dialler Radio Supervision Poll Fail	355	103	355	103
Dialler Mains Fail	301	102	301	102
SGIII Battery Test Fail	-	-	309	108
SGIII Low Battery	-	-	302	107
Radio Dialler Low Battery	302	101	302	101
Radio Device Low Battery	384	002-050	384	002-050
Open\Close with user ID	401	001-050	401	001-050
Test call	602	104	602	104
Cancel of Alarm message	406	108	406	001-050

Specifications

RX TYPE	SAWR stabilised
BANDWIDTH (3dB)	800kHz
OPERATING VOLTAGE	17V AC plug pack supplied
QUIESCENT CURRENT DRAW (SLEEP MODE)	1mA
RADIO FREQUENCY	303.85MHz
WEIGHT	450g
BACKUP BATTERY	8.4V 160mA NiMH
DIMENSIONS	210 x 140 x 35mm

NESS RADIO DIALLER
INSTALLATION NOTES
This revision April 2008

Document Part Number 890-217
For Ness Radio Dialler 100-284



NESS SECURITY PRODUCTS
Australian Communications Authority
RADIO COMMUNICATIONS COMPLIANCE

COPYRIGHT NOTICE

All rights reserved. No part of this publication may be reproduced, transmitted or stored in a retrieval system in any form or by any means, electronic, mechanical, photocopying, recording, or otherwise, without the prior written permission of Ness.

Ness reserves the right to make changes to features and specifications at any time without prior notification in the interest of ongoing product development and improvement.

© 2008 Ness Security Products Pty Ltd ABN 28 069 984 372