

# **NEW GUARDPOST**

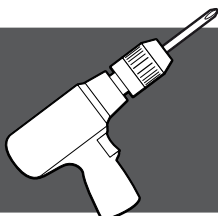

WIRELESS SECURITY SYSTEM  
WITH 3G GSM MONITORING  
& TWO WAY VOICE

THE WORLD'S SMARTEST WIRELESS  
INTRUDER ALARM SYSTEM



## Installation & Programming Manual

Guardpost 3G Installer Rev 1.1



www.nesscorporation.com

National Customer Service Centre  
Ph: 1300 551 991  
customerservice@ness.com.au



## Guardpost 3G Installation & Programming Manual Rev1.1

Document Part No: 890-430  
Revised Apr 2017

For the products:  
Ness Guardpost 3G + Two Way Voice



### WARNINGS & NOTICES

Ness Corporation manufacturing processes are accredited to ISO9001 quality standards and all possible care and diligence has been applied during manufacture to ensure the reliable operation of this product. However there are various external factors that may impede or restrict the operation of this product in accordance with the product's specification.

These factors include, but are not limited to:

1. Erratic or reduced radio range (if radio accessories are installed). Ness radio products are sophisticated low power devices, however the presence of in-band radio signals, high power transmissions or interference caused by electrical appliances such as Mains Inverters, Wireless Routers, Cordless Phones, Computers, TVs and other electronic devices may reduce radio range performance. While such occurrences are unusual, they are possible. In this case it may be necessary to either increase the physical separation between the Ness receiver and other devices or if possible change the radio frequency or channel of the other devices.
2. Unauthorised tampering, physical damage, electrical interruptions such as mains failure, electrical spikes or lightning.
3. Solar power inverters are a known source of electrical interference. Please ensure that this product and all associated cabling is installed at least 3 metres away from a solar power inverter and its cabling.

**WARNING:** Installation and maintenance to be performed only by qualified service personnel.

**CAUTION:** Risk of explosion if battery is replaced by an incorrect type. Dispose of used batteries in accordance with local regulations.

All rights reserved. No part of this publication may be reproduced, transmitted or stored in a retrieval system in any form or by any means, electronic, mechanical, photocopying, recording, or otherwise, without the prior written permission of Ness.

Ness reserves the right to make changes to features and specifications at any time without prior notification in the interest of ongoing product development and improvement.

© 2017 Ness Corporation Pty Ltd ABN 28 069 984 372

# CONTENTS

Guardpost Features	4
Compatibility	4
Introduction	4
Product Overview	5
Installation	6
SIM Card Installation	7
Wiring	7
Startup	8
Radio Keys	8
User Operation	9
Arm/Disarm By SMS	10
Device Allocation	11
Front Panel Control Buttons	11
Main Motion Detector	11
Alarm Displays	12
System Displays	13
Event Log	13
Power Management	14
Solar Charging	14
Programming	15-17
Programming Options	18-25
Programming Options Summary	26
Programming by SMS	27-29
Central Station Reporting operation	30
SMS Reporting operation	31
Audible Reporting operation	32
TWO-WAY-VOICE MONITORING	33
Radio Siren option	34
Dialler Listen-IN Function	34
Dialler Swinger Shutdown	34
Troubleshooting	35
Specifications	36

---

## GUARDPOST FEATURES

- 3G dialler with SMS/Audio/Contact ID reporting
- Two-Way-Voice monitoring and remote arm/disarm
- SMS remote arm/disarm
- SMS remote programming
- Onboard PIR for 15m x 15m coverage plus optional external devices
- Supports up to 24 supervised and encrypted radio devices
- Supports Ness radio PIRs, radio reed switches, radio doorbell transmitter, radio smoke detector, radio keys, radio siren
- Doorbell chime function (requires optional doorbell transmitter)
- Onboard support for Ness Radio Sirens
- Scrolling LED display for easy to read visual display
- Voice annunciation for status, events & user instructions
- Dual Home modes for zoned arming
- Strobe light differentiation for arm/disarm
- Onboard 124dBm siren for an extra loud audible deterrent
- Extensive event memory accessed via the scrolling LED display
- Front panel push-button adjustment for voice & internal beeps volume control
- Sophisticated power management for long battery life
- Up to 4 months operation on internal power
- Solar cell charging support
- Proprietary encryption algorithm for secure comms between radio devices and Guardpost
- Radio Jamming / Radio Substitution detection
- Auxiliary outputs for optional external sirens and strobe

## INTRODUCTION

Guardpost is a fully self contained security system including an on-board motion sensor, loud siren, and wireless receiver for remote sensors and Arm/Disarm radio keys.

Guardpost's sophisticated power management options allow it to run off internal power for up to four months or even run on solar cells allowing it to be installed in almost any type of fixed or portable application.

Guardpost's onboard GSM dialler gives it complete independence from landlines and allows reporting in Contact ID format back to base, audible voice reporting to any telephone, SMS reporting to mobile phones, SMS arming/arming/programming and even Two Way Voice communications for alarm verification and user safety.

Guardpost not only visually reports all events to the user via its large, bright alphanumeric display, it actually speaks to the user to report events and advises on the action to take.

Guardpost uses the latest microprocessor technology ensuring the highest level of security and dependability. The wireless radio keys utilise proprietary encryption algorithms for highest security.

Detection devices such as wireless passive infrared detectors and wireless reed switches also offer a high level of security through the use of programmable supervision techniques and constant monitoring of their battery condition.

Guardpost also helps resolve the growing issue of manpower when it comes to installation. Minimal programming is required allowing a comprehensive system to be installed in under one hour and a basic system in minutes.

Guardpost is made in Australia by Ness Corporation to world class standards using the latest surface mount technology and state of the art in-circuit probe testers, together with strict process controls and adherence to an ISO9001 Quality Assurance Program, ensuring a quality product and a long service life.

---

## COMPATIBILITY

Guardpost is compatible with all Ness radio transmitters.



## PRODUCT OVERVIEW

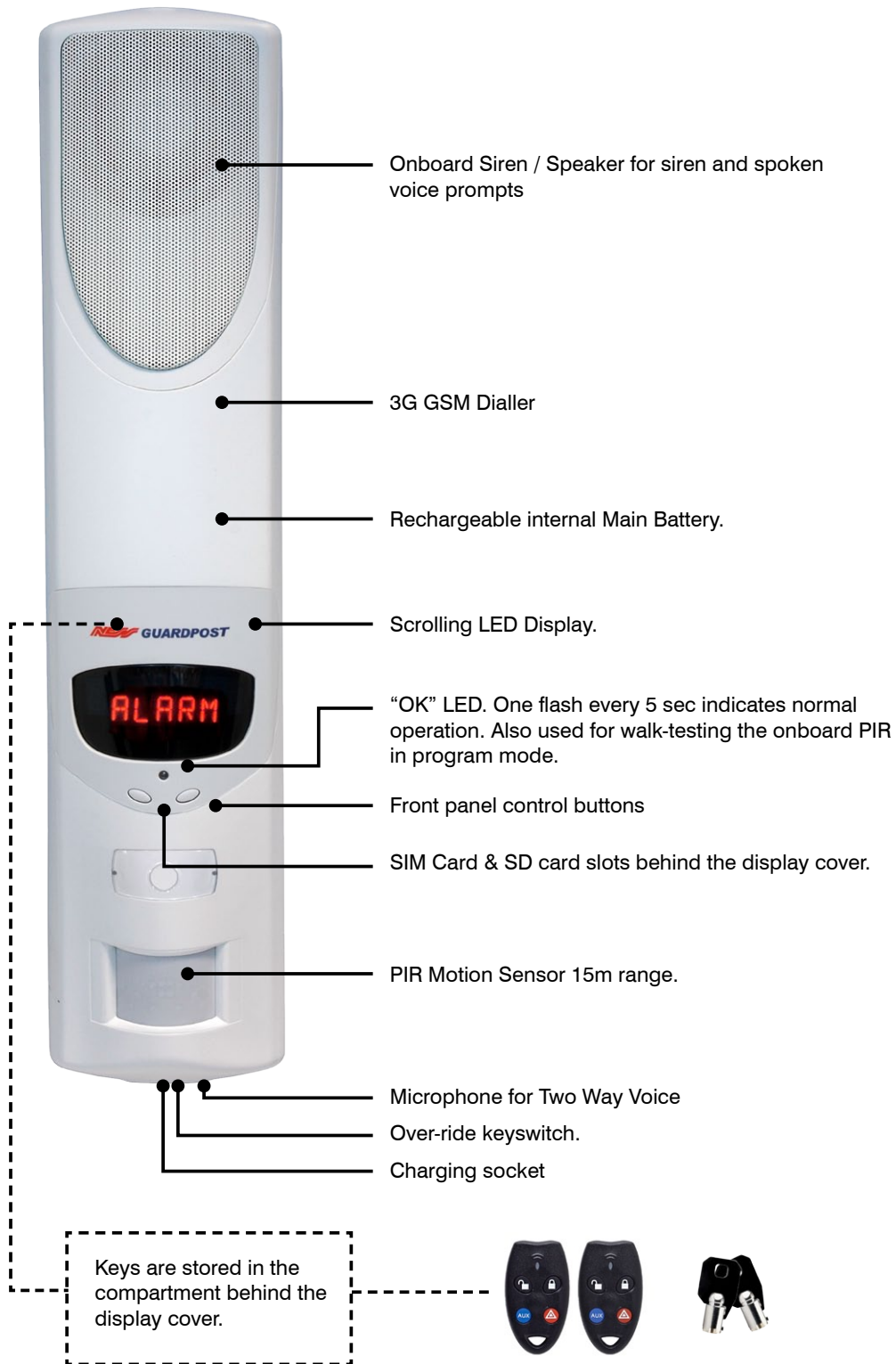

Guardpost is supplied with:

- 2 x Radio keys (Some models are supplied with 3 button radio keys)
- 2 x Over-ride keys
- 1 x 17VAC Plug Pack
- 2 x 3k3 resistors
- 1 x Wire loom & installation kit
- 1 x Ness SIM Card (some models)

## INSTALLATION

The front cover forms a secure clamshell when Guardpost is installed. The unit must be removed from the wall before attempting to remove the front cover.

Screw mounting holes are provided for either flat wall mounting or corner mounting.

Guardpost should be mounted in a position which provides a clear field of view for the onboard PIR.



## GSM ANTENNA

The GSM antenna is internally mounted but can also be moved to the external position which may be more effective depending on the strength of the GSM signal on site.

## SIM CARD INSTALLATION

Your Guardpost may be supplied with a factory-fitted Ness SIM card or install your own 3G SIM card as shown below.

Ness SIM cards are ready for use immediately. If using a third party SIM card ensure that it's not PIN locked.



1  
Remove the display cover.



2  
Insert the SIM card as shown.  
Push to lock. Push to eject.

Note. The SIM card slot should not be confused with the SD card slot adjacent.

## WIRING

Wiring diagram for connecting optional external sirens and strobe.



Wire loom exits at rear of the Guardpost housing

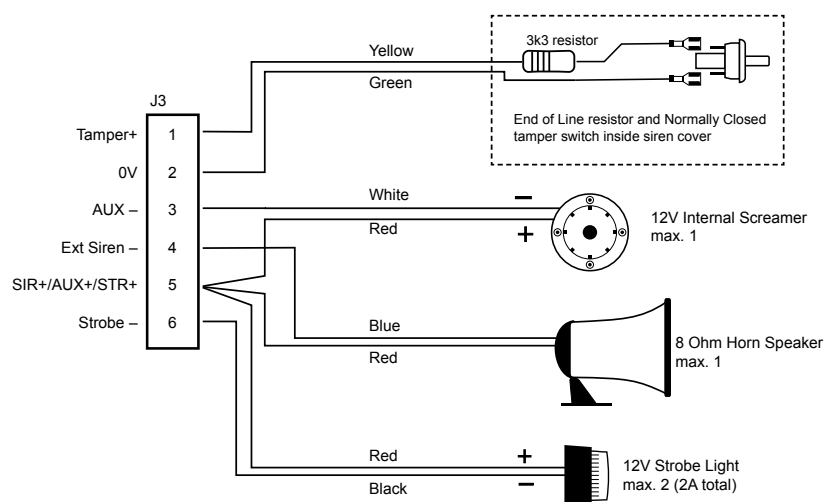

### FLYING LEADS

Red	AC	Optional External 17VAC power input and solar power input
Red	AC	

## STARTUP



After mounting the Guardpost, plug in the AC plug pack for 24hours to fully charge the onboard battery.

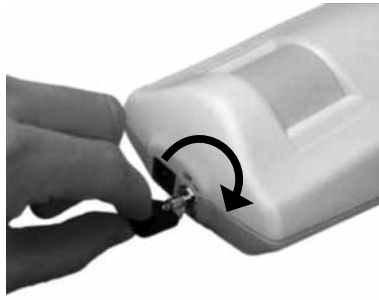

To power-up the unit, turn the main keyswitch clockwise to the ON position.



The display will show the firmware revision number.



When the unit is powered-up it briefly allows entry into PROGRAM mode. See page 15.



Guardpost then enters the previous operational mode.

If the unit was in ARMED, HOME, or HOME 2 mode, it will show the mode on the display for 30 seconds. During this period triggers from the main PIR are ignored, allowing it time to settle.

Then the unit resumes normal operation in the mode displayed. This process will occur silently, without the usual arming sounds.

## RADIO KEYS



Your Guardpost may be supplied with one or more 4 button radio keys, depending on the model.

The 4 button radio key has an additional AUX button which is designed for use with the optional 100-099 AUX Receiver for home automation functions such as lighting control or operating motorised garage doors.

### OPTIONAL AUX RECEIVER









Relay output to:

- Garage door controller
- Lighting
- Sprinkler systems
- Almost any electrical device

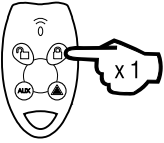
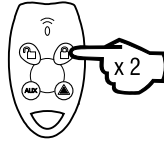
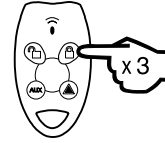
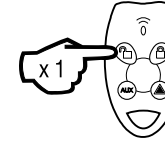
## USER OPERATION

The system can be in one of four user modes, DISARMED, HOME, HOME 2 and ARMED.

From the DISARMED mode, an ON press enters ARMED mode, a second ON press enters HOME mode, and a third ON press enters HOME 2 mode (provided devices are programmed for these modes), as detailed in the following sections.

USER OPERATION MODES	ARMED	HOME	HOME2	DISARMED
HOW TO OPERATE USER MODES				
<b>DISPLAYS AND AUDIBLE FEEDBACK</b>				
 SCROLLING DISPLAY	<b>ARMED</b> Displayed for the duration of exit delay.	<b>HOME</b> Displayed for the duration of exit delay.	<b>HOME 2</b> Displayed for the duration of exit delay.	<b>OFF</b> Displayed for 5 seconds.
 OK LED	OFF	1 Flash every 2 seconds	Double Flash every 2 seconds	1 Flash every 5 seconds
 VOICE	"ARMED" *	"HOME" *	"HOME TWO" *	"DISARMED" *
 SIREN	INTERNAL SIREN# 1 chirp at start of exit delay* and 1 chirp at end of exit delay. EXTERNAL SIREN: 1 chirp at start of exit delay (if enabled).	INTERNAL SIREN# Home arming tone.	INTERNAL SIREN# Home2 arming tone.	INTERNAL SIREN# 3 chirps. EXTERNAL SIREN: 3 chirps (if enabled).
 STROBE LIGHT (If installed)	Flash for 2 seconds.	Flash for 5 seconds.	Flash for 5 seconds.	Flash for 4 seconds.

\* If the V-ARM option is enabled.

# If the V-ARM option is disabled.

Note: At least one device must be programmed as HOME or HOME 2 for the system to allow arming in those modes.

## ARM/DISARM BY SMS



Guardpost supports remote programming by SMS (see page 26-28) and remote arming/disarming by SMS.

To arm/disarm Guardpost by SMS you must know the mobile phone number of the Guardpost's SIM card and the client account number.

### SMS COMMANDS

TO ARM	CCCC,arm
TO DISARM	CCCC,disarm

CCCC is the 4 digit client account number. (see page 21)

#### NOTES

- SMS commands must not include spaces.
- Arm/Disarm commands are not case sensitive.
- The dialler must be enabled to allow operation by SMS.
- SMS reply messages are sent to the mobile phone which sent the SMS commands - which can be any mobile phone.

**IMPORTANT NOTE.**  
Guardpost may not respond to SMS commands immediately if the GSM module is sleep mode.  
The state of the GSM module is dependent on the power management mode.  
See page 24.

### EXAMPLES

To ARM a Guardpost which has the client account number 1234:

Send this SMS to the Guardpost `1234,arm`

Guardpost will reply with `Unit 1234: Armed`

To DISARM the Guardpost:

Send this SMS to the Guardpost `1234,disarm`

Guardpost will reply with `Unit 1234: Disarmed`

### HINTS & TIPS

The Arming and Disarming commands can be abbreviated "a" and "d" meaning you can simply send `1234,a` to Arm and `1234,d` to Disarm.

If you send an SMS in the wrong format, Guardpost will respond with:

`Unit CCCC: Command error.`

The SMS format requires a comma between each command and no spaces.

## DEVICE ALLOCATION



Guardpost supports up to 24 Ness radio devices including the main detector onboard.

This provides up to 23 radio allocations for any combinations of remote devices including radio keys, radio PIRs, radio reed switches, radio smoke detectors, radio doorbell, radio keypad.

At least one radio key must be programmed.

## FRONT PANEL CONTROL BUTTONS



The front panel buttons allow the user to program the options shown below. Press the Left Button to step through each option; press the Right Button to step through the various values for the selected option (the last value selected becomes the new programmed value).

Selected options and values are announced as well as displayed. The display extinguishes after a short period of inactivity.

LEFT BUTTON	RIGHT BUTTON
Adjust MAIN VOLUME - Press x 1	Main Volume 1 – 4
Adjust BELL TYPE - Press x 2	Bell Type 1 – 3
Adjust BELL VOLUME - Press x 3	Bell Volume 1 – 4 – OFF

In Program mode, pressing the Left Button allows stepping backwards through the various options and devices.

## MAIN MOTION DETECTOR



- The onboard PIR (SENSOR 1) conserves power using a lock-out timer after each detection.
- When disarmed, the lockout time is 4 minutes. When armed, the lockout time is 5 seconds between activations.
- The detection coverage of the onboard PIR can be walk-tested when the PULSE or RANGE options are selected in program mode. The main unit OK LED serves as the onboard PIR's alarm indicator when walk testing.

GUARDPOST MODE	MAIN PIR LOCKOUT TIME
DISARMED*	4 minutes
ARMED, HOME, HOME2	5 seconds
PULSE or RANGE is selected in Program mode	0 seconds to allow walk test

\* Unless the onboard PIR is configured as CHIME

## ALARM DISPLAYS



Intruder Alarms will sound the internal and external (if fitted) sirens and strobe flashes. The siren will turn off after the programmed siren time and the strobe will flash for 1 hour or 12 hours if the system is running on mains power.

Press the OFF button on a programmed Radio Key to cancel the alarm and disarm the GUARDPOST.

When disarming after an alarm, Guardpost will indicate an alarm has occurred by voice and by display. This warning may indicate that an intruder is still present. The source of the alarm is then displayed for 5 minutes, and logged to the event memory.

Intruder alarms are not indicated when the system is in ARMED, HOME or HOME 2 modes.

A time stamp is appended to each of the following alarm messages displayed when displayed. For example, if the alarm occurred within 24 hours, the time stamp is appended as: ... < 2 HRS < 15 MIN < AGO; for events older than 24 hours: ... < 1 DAY < 13 HRS < AGO.

DISPLAY	DESCRIPTION
ALARM < SENSOR < 1	ALARM from the onboard detector
ALARM < SENSOR < 2-23	ALARMS from radio devices such as radio PIRs, radio reed switches.
TAMPER < SIREN < BOX	SIREN TAMPER In ARMED mode, sound a full alarm & report to the central monitoring station when applicable. In HOME, HOME 2 or DISARMED modes, sound a low-volume warning sound & report. The warning will sound again for further Tamper deactivation/reactivations. Arming and Disarming will clear the display.
TAMPER < SENSOR < 2-23	A Sensor has reported a tamper alarm. In ARMED mode, sound a full alarm & report to the central monitoring station when applicable. In HOME, HOME 2 or DISARMED modes, sound a low-volume warning sound & report. The warning will sound again for further Tamper deactivation/reactivations. Arming and Disarming will clear the display.
PANIC < KEY < 1-23	PANIC ALARM from a radio key or fixed radio panic button or radio medical key. On silencing a PANIC alarm (OFF button), the status display indicates which key caused the alarm.
MEDIC < KEY < 1-23	PANIC ALARM from a medical key. During the alarm the display will show "PRESS < OFF < TO < CANCEL < MEDIC < ALARM". On disarming, the status display indicates which key caused the alarm.
RADIO < JAMMED	Radio jamming signal detected. If a radio signal is detected in the operating bandwidth of the Guardpost the unit will go into ALARM mode if enabled.
RADIO < TAMPER	TAMPER Radio message that is not an original message has been received. (If RADSUB = ON). 1. A code that is a retransmitted code of an original message has been received to try to defeat the system. 2. 20 multiple messages have been received by the system to crack the encryption. Arming/Disarming the system will reset the count.

## SYSTEM DISPLAYS



System troubles are indicated in the DISARMED mode. When DISARMING after a trouble alarm the GuardPost will display the type of trouble alarm with a time stamp.

The message will be displayed for 5 minutes.

DISPLAY	DESCRIPTION
BATTERY < KEY BATTERY < PANIC BATTERY < BELL	A radio key, radio panic button or radio doorbell transmitter has a low battery. The battery should be replaced. Some transmitters are sealed units designed to last for many years. These units should be replaced for new.
BATTERY < SENSOR < 2-23	A radio PIR or radio reed switch has a low. The battery should be replaced.
FAIL < SENSOR < 2-23	A supervision signal has not been received within the programmed supervision interval. (See the program option SUPVIS). Check that the sensor is present and working correctly. This only applies to supervised sensors.
OPEN < SENSOR < 2-23	A REED SWITCH is open on ARMING A reed switch detector programmed for Check mode operation was unsealed when entering ARMED, HOME or HOME 2 modes. The detector should be checked to ensure that it has sealed. A warning tone will sound at the end of EXIT DELAY when ARMED.
LOW < MAIN < BATTERY	MAIN BATTERY LOW The main unit battery is periodically load tested. A low battery condition is cleared immediately when mains power goes from off to on, or when battery passes load test.
FAULT < MAIN < BATTERY	MAIN BATTERY FAULT The main unit battery failed load-test immediately following recharge cycle. The alarm can be cleared by switching the over-ride switch off then on.
DIALER < RADIO < FAIL	DIALLER RADIO FAIL Guardpost was not able to communicate with the optional radio dialler. (If installed).

## EVENT LOG



System alarm events are logged in memory and displayed with the time elapsed since the alarm occurred. Multiple alarms from the same device are logged only once, with the time stamp updated for each new repeat alarm.

In DISARMED mode, press OFF to step through the log. Once all logged alarms have been displayed, pressing OFF will clear the display. Pressing OFF again will redisplay the first event in the log, etc.

Entries in the log will be cleared only when the cause of the alarm has been rectified, or when power is turned off using the key switch.

The alarm event log will store up to 5 events. If the log is full, logging a new event causes the oldest event to be discarded. Events older than 100 days will be discarded.

A time stamp is appended to each event when displayed. For example, if the alarm occurred within 24 hours, the time stamp is appended as: ... < 2 HRS < 15 MIN < AGO; for events older than 24 hours: ... < 1 DAY < 13 HRS < AGO.

---

## POWER MANAGEMENT

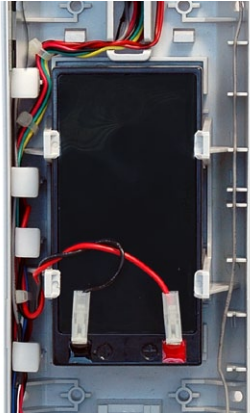

Guardpost employs sophisticated power management software to maximise main battery life and increase the time between charging. Guardpost can be operated in FULL TIME MAINS mode, BATTERY ONLY mode or SOLAR CELL charge mode.

In Full Time Mains Mode, Guardpost constantly trickle charges the main battery.

Battery Only mode and Solar Cell modes are low current modes designed to consume the minimal power by shutting down non-essential circuits and by the use of sleep/wake cycles. See the programming option POWER for more information.

In power conservation modes Guardpost can be operated for up to 4 months without recharging. In this case, Guardpost will initiate fast-charging mode for 24 hours once the mains charger is connected.

The OK light will remain on during fast charging only.

### LOAD TEST

A battery test is performed by briefly applying a simulated load on power-up, every 24 hours, on disarming and 3 hours after the completion of a recharge cycle (only if mains was on at the end of recharge cycle, and no siren activity occurred after recharge period).

### ALARMS

If a low battery is detected when mains is on, no alarm is displayed or reported, but the battery is recharged for 24 hours.

If a low battery is detected and mains is off, a LOW < MAIN < BATTERY alarm is displayed and reported if enabled, and the battery is recharged for 24 hours when mains comes on. When mains comes on, the alarm condition is immediately cleared and restored.

If a low battery is detected after the completion of a recharge cycle, a FAULT < MAIN < BATTERY alarm is displayed and unconditionally reported. If the battery passes a subsequent load test, this condition is restored.

## SOLAR CHARGING



Guardpost has onboard support for power supply and charging by solar cells.

- Solar cell power input connects to the AC red wires for the solar connections.
- Select SLR-30, SLR-1H or SLR-2H power management mode.
- A 12V 10W-20W solar panel is recommended with max power output of 17.6V.

Guardpost makes efficient use of available solar power by switching between fast charge and float charge while monitoring the battery capacity at all times.

See Power Management Mode, page 24.

## PROGRAMMING

### TO ENTER PROGRAM MODE

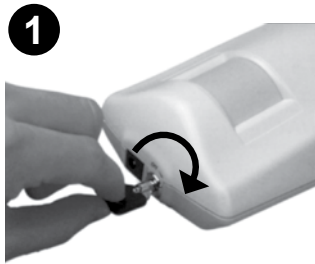

1

To enter program mode, turn on the main keyswitch.



The software revision number is briefly displayed.

### TO LEARN THE FIRST RADIO KEY



2

If unit has no radio keys learned, the display will show LEARN KEY 1 until a radio key is learned.

**Guardpost requires at least one radio key to be active before you can proceed with further programming.**



Press PANIC for 8 seconds to learn a new radio key.

Once the radio key is successfully programmed, Guardpost will give a BEEP, BEEP, BEEP-BEEP. The unit will add the new device to the next available slot, display the new slot number, and allow the user to configure the new device.

### TO LEARN OTHER RADIO DEVICES



3

If the Guardpost already has a radio key programmed it flashes LEARN and waits 10 seconds to receive a radio key message.



4

Press the ON button on a valid radio key to enter Ready to Learn mode.



5

The display flashes READY and is waiting for a LEARN message from a new device (key or detector).



6

Send the Learn Signal from the new radio device.  
See next page. How to send a LEARN signal.



7

The display will show the new Key or Sensor number.  
New devices are added to the next available vacant slot.



8

Press the ON button on a valid radio key to view the sub-menu options for the device. See page 18 for sub-menu options for radio keys and radio devices.

Press OFF to return to LEARN.

Press ON to flash READY and learn another device, or press OFF to step through devices and program options.

3

**At step 3 the system will wait 10 seconds for a keypress otherwise it will exit program mode.**

## PROGRAMMING

### HOW TO SEND A LEARN SIGNAL FROM RADIO DEVICES

RADIO KEYS	Press PANIC for 8 seconds.	
DOORBELL / FIXED PANIC	Press the button 3 times.	
RADIO PIRS RADIO SMOKE DETECTORS RADIO KEYPAD	Insert the battery.	
RADIO REED SWITCHES	UNENCRYPTED DEVICES Check Mode: Close the reed switch. (Move the magnet towards). Non-Check Mode: Open the reed switch. (Move the magnet away).	ENCRYPTED DEVICES Check Mode: Insert the battery with the reed switch closed. (Magnet on the reed switch). Non-Check Mode: Insert the battery with the reed switch open. (Magnet away from the reed switch).
	Reed Switch devices (door/window sensors) may be learned as a Checked device. This means the door or window needs to be closed before the system can be armed. If the sensor is not closed on arming the system will announce and display the sensor number. When learning devices, the OK LED turns on when Check mode operation is successfully programmed.	

### ERROR TONE

When learning device an ERROR TONE could mean:

POSSIBLE CAUSE	REMEDY
1. The device is already programmed	Remove the battery from this device to prevent it sending signals while you program other devices.
2. The device is not compatible with the Guardpost (possibly a different radio protocol).	Check with your Ness branch.
3. The device might be too close to the Guardpost.	When enrolling/learning radio devices maintain at least 2m separation from the Guardpost to prevent errors caused by excessive signal strength.

### DELETING A RADIO KEY OR SENSOR

The sub-menu for each enrolled radio key and sensor includes the option to ERASE. To delete the device select ERASE and press PANIC to store the selection. The display will then show LEARN, giving the user the option of reprogramming a new device into this particular slot. This allows a faulty device to be replaced while keeping the same slot number.

### PROGRAMMING NOTES

- All programming is performed using an enrolled radio key.
- To prevent learning the wrong device, start programming with the batteries removed from all devices on site. Once a device is learned remove its battery until all devices are learned.
- Each time a programming change is made, the new value is stored immediately in non-volatile memory.
- Guardpost will flash FULL if an attempt is made to program a device when no slot is available. It will allow programmed devices to be viewed in sequence and erased if desired.
- A key cannot be used to erase itself. A device cannot be programmed more than once. Guardpost will give a long warning beep if either are attempted.
- Guardpost will automatically exit PROGRAM mode after 10 minutes of inactivity.

---

## PROGRAMMING

### NAVIGATION IN PROGRAM MODE

---

#### 1. STEPPING THROUGH THE PROGRAMMING MENU

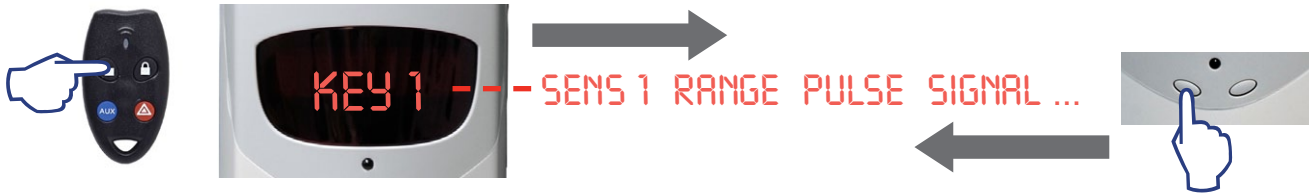

Press the OFF button on a valid radio key to step forward through the programming menu.

The LEFT front panel button cycles BACKWARD through the programming menu.

#### 2. CHOOSE A SUB-MENU OPTION



Press the ON button to cycle through the sub-menu options for a programming option.

#### 3. SAVE THE VALUE



Press the PANIC button to store the currently displayed value. The new value will then flash to indicate it is programmed.

### TO EXIT PROGRAM MODE

---





Select P-EXIT from the programming menu.

Then press the ON button to exit program mode.

Otherwise Guardpost will automatically exit PROGRAM mode after 10 minutes of inactivity.

## PROGRAMMING OPTIONS

<p><b>KEY 1-23</b></p> 	<p><b>RADIO KEYS</b></p> <p><b>Sub-menu</b></p> <p><b>KEY</b> Enables the radio key for use as a user key with Arm, Disarm, Panic, Aux (<b>DEFAULT</b>)</p> <p><b>DURESS</b> User key with PANIC button programmed for "DURESS" operation</p> <p><b>MEDIC</b> Medical help key (behaves like Duress alarm)</p> <p><b>BELL</b> Doorbell</p> <p><b>NO PAN</b> PANIC button disabled (except in Program mode); used for control of independent radio switch, e.g. garage door control</p> <p><b>ERASE</b> Deletes the programmed radio key</p>
<p><b>SENS 1</b></p> 	<p><b>ONBOARD PIR</b></p> <p><b>Sub-menu</b></p> <p><b>ALARM</b> Active when ARMED, inactive when DISARMED (<b>DEFAULT</b>)</p> <p><b>HOME</b> Active when ARMED mode or HOME mode</p> <p><b>HOME 2</b> Active when ARMED, HOME or HOME 2 modes</p> <p><b>FIRE</b> 24 hour alarm, always active</p> <p><b>CHIME</b> Chime* when DISARMED, inactive when ARMED, HOME or HOME 2 modes</p> <p><b>ACHIME</b> ALARM/CHIME Alarm when ARMED, chime** when DISARMED, inactive when in HOME or HOME 2 modes</p> <p><b>HCHIME</b> HOME/CHIME Alarm when ARMED mode, chime** when in HOME mode, inactive when in HOME 2 or DISARMED modes</p> <p><b>H2CHIM</b> HOME 2/CHIME Alarm when ARMED mode, chime** when in HOME or HOME 2 modes, inactive when in DISARMED mode</p> <p><b>SILENT</b> Active when ARMED, only does dialler reporting when triggered, no siren</p> <p><b>EXCLUD</b> Disables the onboard PIR</p>
<p><b>SENS 2-23</b></p> <p>Optional sensors can be any combination of up to 22 radio PIRs, radio reed switches, radio smoke detectors, radio doorbell, radio keypad.</p> 	<p><b>RADIO DEVICES 2-23</b></p> <p><b>Sub-menu</b></p> <p><b>ALARM</b> Active when ARMED, inactive when DISARMED (<b>DEFAULT</b>)</p> <p><b>HOME</b> Active when ARMED mode or HOME mode</p> <p><b>HOME 2</b> Active when ARMED, HOME or HOME 2 modes</p> <p><b>FIRE</b> 24 hour alarm, always active.</p> <p><b>CHIME*</b> Chime when DISARMED, inactive when ARMED, HOME or HOME 2 modes</p> <p><b>ACHIME**</b> Alarm when ARMED, chime when DISARMED, inactive when in HOME or HOME 2 modes</p> <p><b>HCHIME**</b> Alarm when ARMED mode, chime when in HOME mode, inactive when in HOME 2 or DISARMED modes</p> <p><b>H2CHIM**</b> Alarm when ARMED mode, chime when in HOME or HOME 2 modes, inactive when in DISARMED mode</p> <p><b>SILENT</b> Active when ARMED, only does dialler reporting when triggered, no siren.</p> <p><b>ERASE</b> Erase this device</p> <p>* Chime tone (no Dialler report or event logging)</p> <p>** Warning tone (no Dialler report or event logging)</p>

## PROGRAMMING OPTIONS

<b>RANGE</b>	<b>ONBOARD PIR RANGE</b>
	<p><b>Sub-menu</b>            LOW      Low range 8m <b>(DEFAULT)</b>            HIGH      High range 14m</p> <p>The onboard PIR can be walk-tested while this menu item is displayed.</p>
<b>PULSE</b>	<b>ONBOARD PIR PULSE COUNT</b>
	<p><b>Sub-menu</b>            1 PULS      1 pulse count <b>(DEFAULT)</b>            2 PULS      2 pulse count            3 PULS      3 pulse count            4 PULS      4 pulse count</p> <p>The onboard PIR can be walk-tested while this menu item is displayed.</p>
<b>SIGNAL</b>	<b>RADIO SIGNAL STRENGTH CHECK</b>
<p>Check the signal strength of your radio keys and radio devices.</p> <p>Note: OK light indicates onboard PIR trigger.</p>	<p><b>Sub-menu</b>            SEND DEVICE      Waiting for device message            SENS 2-23 / LEVEL 1-9      Detector received at signal strength level shown            KEY 1-23 / LEVEL 1-9      Key received at signal strength level shown</p> <p>Guardpost registers the first device received and displays the signal strength (1-9), and beeps a corresponding number of times.</p> <ul style="list-style-type: none"> <li>• Press ON to activate Signal Check</li> <li>• For a key, press PANIC; for a detector, activate the detector</li> <li>• Listen to beeps, view display</li> <li>• Press OFF to exit Signal Check</li> <li>• Press ON to re-activate Signal Check</li> </ul>
<b>RADJAM</b>	<b>RADIO JAMMING ALARM</b>
	<p><b>Sub-menu</b>            ON      Enabled            OFF      Disabled <b>(DEFAULT)</b>            SILENT      Dialler report only (no local siren, display or logging). Limit of 10 reports; limit cleared on arming. Use for transparent monitoring of radio interference.</p> <p>When RADJAM is enabled Guardpost will generate a chime in modes DISARMED, HOME, HOME 2 if it receives a continuous source of Radio Frequency Interference (RFI). In ARMED mode the system will go into a full alarm mode.</p>
<b>RADSUB</b>	<b>RADIO MESSAGE SUBSTITUTION ALARM</b>
	<p><b>Sub-menu</b>            ON      Enabled            OFF      Disabled <b>(DEFAULT)</b></p> <p>When RADSUB is enabled Guardpost will generate a CHIME alarm in DISARMED or HOME or HOME 2 modes, and a full alarm in ARMED modes if it senses an intentional radio message substitution.</p>
<b>SUPVIS</b>	<b>RADIO SUPERVISION INTERVAL</b>
	<p><b>Sub-menu</b>            OFF      Disabled <b>(DEFAULT)</b>            1 HR            4 HRS            8 HRS            16 HRS            24 HRS</p> <p>If enabled, a system alarm will occur if a valid supervisory message has not been received from supervised radio within the programmed interval.</p>

## PROGRAMMING OPTIONS

<b>LOKOUT</b>	<b>ALARM LOCKOUT</b>
	<p><b>Sub-menu</b>  ON Enabled  OFF Disabled (<b>DEFAULT</b>)</p> <p>Alarm lockout prevents multiple sirens sounding due to an alarm from the same device. The external siren will not sound again until the system is disarmed with the Disarm/Unlock button. The internal siren will always sound unless the lockout option is on and then the internal siren will behave like an external siren.</p>
<b>ENTRY</b>	<b>ENTRY DELAY TIME</b>
Entry delay time applies to all enrolled devices.	<p><b>Sub-menu</b>  5 SEC (<b>DEFAULT</b>)  10 SEC  15 SEC  20 SEC  25 SEC  30 SEC</p> <p>Entry Delay Time allows time to disarm the system once a detector is activated. Guardpost is normally armed/disarmed by radio keys from outside the protected area but in some situations you may want to disarm from inside the premises.</p>
<b>EXIT</b>	<b>EXIT DELAY TIME</b>
Exit delay time applies to all enrolled devices.	<p><b>Sub-menu</b>  5 SEC (<b>DEFAULT</b>)  to 60 SEC in 5 second steps</p> <p>Exit Delay Time allows time to exit the premises once the system is armed. All radio devices are inactive during Exit Delay.</p>
<b>SIREN</b>	<b>SIREN RUN TIME</b>
	<p><b>Sub-menu</b>  1 MIN  2 MIN  3 MIN  4 MIN  5 MIN (<b>DEFAULT</b>)</p> <p>Sets the run time in minutes for the internal and optional external siren (if fitted).</p>
<b>CHIRPS</b>	<b>EXTERNAL SIREN CHIRPS</b>
<p><b>External Siren</b>  ARMING: 1 Chirp  DISARMING: 3 Chirps</p>	<p><b>Sub-menu</b>  ON Enabled (<b>DEFAULT</b>)  OFF Disabled</p> <p>This option enables arm/disarm chirps for the external siren. External Siren Chirp applies only to Arming/Disarming. HOME or HOME 2 modes never chirp.</p>
<b>V-ARM</b>	<b>VOICE ANNUNCIATION FOR ARMING/DISARMING</b>
<p>When V-ARM is disabled the internal speaker will chirp on arming and disarming.</p> <p><b>Internal Siren</b>  ARMING: 1 Chirp  DISARMING: 3 Chirps</p>	<p><b>Sub-menu</b>  ON Enabled (<b>DEFAULT</b>)  OFF Disabled</p> <p>This option enables voice annunciation of Arming and Disarming.</p>

## PROGRAMMING OPTIONS

<b>V-ALRM</b>	<b>VOICE ANNUNCIATION FOR ALARMS</b>
	<p><b>Sub-menu</b>  ON Enabled (<b>DEFAULT</b>)  OFF Disabled</p> <p>This option enables voice annunciation of Alarm events.</p>
<b>V-BATT</b>	<b>VOICE ANNUNCIATION FOR BATTERY ALARMS</b>
	<p><b>Sub-menu</b>  ON Enabled (<b>DEFAULT</b>)  OFF Disabled</p> <p>This option enables voice annunciation of low battery events.</p>
<b>V-FALT</b>	<b>VOICE ANNUNCIATION FOR SYSTEM FAULTS</b>
	<p><b>Sub-menu</b>  ON Enabled (<b>DEFAULT</b>)  OFF Disabled</p> <p>This option enables voice annunciation of system faults.</p>
<b>OPEN</b>	<b>OPEN/CLOSE REPORTS</b>
Applicable when using central station monitoring.	<p><b>Sub-menu</b>  OFF All disabled (<b>DEFAULT</b>)  ON Open/Close Reports enabled (sent at end of exit delay)  RESTOR* Alarm Restores enabled  RES+OC* Alarm Restores and Open/Close Reports enabled</p> <p>Open and Close reporting options.</p> <p>* Note. Restorals are reported only by 3G and are <b>not</b> sent via SMS.</p>
<b>LOWBAT</b>	<b>LOW BATTERY REPORTING</b>
Applicable when using central station monitoring.	<p><b>Sub-menu</b>  NONE No low battery reporting (<b>DEFAULT</b>)  MAIN Report low main battery  SENSOR Report low detector batteries (including Fixed Panic Buttons)  ALL Report low main unit and detector batteries</p> <p>Low Battery reporting options.</p>
<b>CLIENT</b>	<b>CLIENT ACCOUNT NUMBER</b>
<p>Applicable when using central station monitoring.</p> <p>Four digit client account number.</p> <p>Allowable range.  0000-FFFF  Digits can be hexadecimal, but 'A' is not allowed for protocol compatibility.</p>	<ul style="list-style-type: none"> <li>• Press ON to view the programmed client account number. The first digit will flash.</li> <li>• Press ON to step through values for the first digit.</li> <li>• Press PANIC to store the digit. The second digit will now flash.</li> <li>• Repeat for the remaining digits.</li> <li>• Press PANIC to store the last digit, and first digit will flash.</li> <li>• Repeat programming procedure to make corrections, or press OFF to return to top level</li> </ul>

## PROGRAMMING OPTIONS

<b>PHONE 1</b>	<b>TELEPHONE NUMBER 1</b>										
<p>Applicable when using central station, audible or SMS monitoring.</p> <p>The dialler is disabled if PHONE 1 or PHONE 2 are blank.</p> <p>When the dialler is disabled the Guardpost will also not accept SMS operation or programming commands.</p> <p>20 digits maximum.</p>	<p>Telephone number 1 is used for reporting alarms to a central monitoring station, audible voice reporting or SMS reporting to a mobile phone.</p> <ul style="list-style-type: none"> <li>• Press ON to view programmed phone number, which be displayed in successive 6-digit segments, after which the first segment will be displayed with the first digit will be flashing.</li> <li>• Press OFF to leave the number unchanged and step to the next option.</li> <li>• Press ON to step through values for the first digit:</li> <li>• Press PANIC to store the first digit. The second digit will flash.</li> <li>• Repeat for each digit (the display will scroll left after the fourth digit is entered).</li> <li>• Press ON to store the last digit, then press OFF, which returns to PHONE 1</li> <li>• Press OFF to step to next option, or repeat procedure to make corrections.</li> <li>• The phone number can be deleted by reprogramming each digit with a PAUSE.</li> </ul> <p>Allowable digits</p> <table border="1"> <tr> <td>-</td> <td>PAUSE</td> </tr> <tr> <td>0-9</td> <td>digits 0-9</td> </tr> <tr> <td>*</td> <td>STAR</td> </tr> <tr> <td>H</td> <td>HASH</td> </tr> <tr> <td>+</td> <td>Dials the international access prefix</td> </tr> </table>	-	PAUSE	0-9	digits 0-9	*	STAR	H	HASH	+	Dials the international access prefix
-	PAUSE										
0-9	digits 0-9										
*	STAR										
H	HASH										
+	Dials the international access prefix										
<b>PHONE 2</b>	<b>TELEPHONE NUMBER 2</b>										
<p>Applicable when using central station, audible or SMS monitoring.</p> <p>The dialler is disabled if PHONE 1 or PHONE 2 are blank.</p> <p>When the dialler is disabled the Guardpost will also not accept SMS operation or programming commands.</p> <p>20 digits maximum.</p>	<p>Telephone number 2 is used as a secondary phone number for reporting alarms to a central monitoring station, audible voice reporting or SMS reporting to a mobile phone.</p> <ul style="list-style-type: none"> <li>• Press ON to view programmed phone number, which be displayed in successive 6-digit segments, after which the first segment will be displayed with the first digit will be flashing.</li> <li>• Press OFF to leave the number unchanged and step to the next option.</li> <li>• Press ON to step through values for the first digit:</li> <li>• Press PANIC to store the first digit. The second digit will flash.</li> <li>• Repeat for each digit (the display will scroll left after the fourth digit is entered).</li> <li>• Press ON to store the last digit, then press OFF, which returns to PHONE 1</li> <li>• Press OFF to step to next option, or repeat procedure to make corrections.</li> <li>• The phone number can be deleted by reprogramming each digit with a PAUSE.</li> </ul> <p>Allowable digits</p> <table border="1"> <tr> <td>-</td> <td>PAUSE</td> </tr> <tr> <td>0-9</td> <td>digits 0-9</td> </tr> <tr> <td>*</td> <td>STAR</td> </tr> <tr> <td>H</td> <td>HASH</td> </tr> <tr> <td>+</td> <td>Dials the international access prefix</td> </tr> </table>	-	PAUSE	0-9	digits 0-9	*	STAR	H	HASH	+	Dials the international access prefix
-	PAUSE										
0-9	digits 0-9										
*	STAR										
H	HASH										
+	Dials the international access prefix										
<b>GSM SG</b>	<b>GSM SIGNAL STRENGTH</b>										
<p>Range 0-9</p> <p>0, low signal</p> <p>9, best signal</p>	<p>Indicates 3G network signal strength.</p>										
<b>ABORT</b>	<b>DIALLER ABORT DELAY</b>										
<p>Applicable when using central station, Audible or SMS monitoring.</p>	<p><b>Sub-menu</b></p> <p>0 SEC</p> <p>10 SEC (<b>DEFAULT</b>)</p> <p>...</p> <p>to 60 SEC</p> <p>in 5 second steps</p> <p>Dialler abort delay gives the opportunity to abort sending an alarm message to the central monitoring station within the programmed time (i.e. to cancel a false alarm).</p>										

## PROGRAMMING OPTIONS

<p><b>MEDIC</b></p> <p>Applicable when using central station, Audible or SMS monitoring.</p>	<p><b>MEDICAL KEY ABORT DELAY</b></p> <p><b>Sub-menu</b>            0 SEC            5 SEC            10 SEC            15 SEC            20 SEC (<b>DEFAULT</b>)            ...            to 60 SEC            in 5 second steps</p> <p>Medical key abort delay gives the opportunity to abort sending an alarm message to the central monitoring station within the programmed time (i.e. to cancel a false alarm).</p>
<p><b>T-CALL</b></p> <p>Applicable when using central station monitoring.</p> <p>Test calls are automatically disabled when SMS or Audible reporting is set.</p>	<p><b>DIALLER TEST CALLS</b></p> <p><b>Sub-menu</b>            OFF      Test calls disabled (<b>DEFAULT</b> when DIALER = SMS or AUDIBLE)            1 DAY            7 DAY    (<b>DEFAULT</b> when DIALER = Contact ID)            14 DAY            30 DAY</p> <p>This option enables periodic test reports.</p> <p>Test reports are sent to the central station via 3G in Contact ID format.            Test reports are NOT sent by SMS or Audible format.</p>
<p><b>DIALER</b></p>	<p><b>DIALLER REPORTING FORMAT</b></p> <p>This option sets the onboard dialler's alarm reporting method.</p> <p><b>Sub-menu</b>            MMSPIC    GSM/3G module, MMS reporting <b>OPTION IS NOT APPLICABLE TO THIS MODEL</b>            GSMCID    GSM/3G module, contact ID reporting            GSMSMS    GSM/3G module, SMS reporting            GSMAUD    GSM/3G module, audible reporting            OFF        DIALLER is disabled</p>

## PROGRAMMING OPTIONS

POWER	POWER MANAGEMENT MODE
<p>Guardpost power management options ensure long battery life under various power supply scenarios.</p>	<p><b>Sub-menu</b></p> <p>BATT Battery mode, GSM module 24 hours wake-up when mains is off <b>(DEFAULT)</b></p> <p>BAT-30 Battery mode, GSM module 30 min wake-up when mains is off</p> <p>BAT-1H Battery mode, GSM module 1 hour wake-up when mains is off</p> <p>BAT-2H Battery mode, GSM module 2 hour wake-up when mains is off</p> <p>AC-ON AC mode, GSM module is on all the time</p> <p>SLR-30 Solar Cell charge mode, GSM module 30 min wake-up</p> <p>SLR-1H Solar Cell charge mode, GSM module 1 hour wake-up</p> <p>SLR-2H Solar Cell charge mode, GSM module 2 hours wake-up</p> <p><b>BATT</b> GSM module will be turned off if no activity. GSM module will be turned on once every 24 hours for 2 minutes to check SMS remote Arm/Disarm command if there is no event report within the whole 24 hours period. AC should be plugged in for charging for 24 hours when battery is low. Typical battery life in this mode is 100 days.</p> <p><b>BAT-30</b> GSM module will be turned on every 30 minutes for 2 minutes to check SMS remote Arm/Disarm command. AC should be plugged in for charging for 24 hours when battery is low. Typical battery life in this mode is 20 days.</p> <p><b>BAT-1H</b> GSM module will be turned on every 1 hour for 2 minutes to check SMS remote Arm/Disarm command. AC should be plugged in for charging for 24 hours when battery is low. Typical battery life in this mode is 25 days.</p> <p><b>BAT-2H</b> GSM module will be turned on every 2 hours for 2 minutes to check SMS remote Arm/Disarm command. AC should be plugged in for charging for 24 hours when battery is low. Typical battery life in this mode is 55 days.</p> <p><b>Note 1:</b> For the above battery modes, if AC is connected, the GSM module will be turned on automatically so that GUARDPOST can receive remote SMS Arm/Disarm instantly.</p> <p><b>AC-ON</b> In this mode Guardpost should be permanently powered by mains plug pack. The backup battery will guarantee at least two days normal run in case of AC failure. GSM module will be ON all the time in this mode and GUARDPOST will receive SMS messages instantly.</p> <p><b>SLR-30/ SLR-1H/ SLR-2H</b> Solar Cell charge mode. In this mode, the backup battery is charged by solar cells. To keep system current low, the GSM module will be turned off when there is no activity, and will be turned on every 30 minutes/ 1 hour/ 2 hours for 2 minutes to check SMS remote Arm/Disarm command.</p>

## PROGRAMMING OPTIONS

<b>CAMERA</b>	<b>NUMBER OF CAMERAS</b>
<p><b>NOTE</b> The factory default is NONE however the DEFAULT option will set the number of cameras to 1. Please return to this option after performing a default and set the number of cameras back to NONE.</p>	<p><b>OPTION IS NOT APPLICABLE TO THIS MODEL</b></p> <p><b>Sub-menu</b>                  2 CAM      Two cameras                  1 CAM      One camera                  None        No camera (DEFAULT)</p>
<b>PICS</b>	<b>NUMBER OF PICTURES</b>
	<p><b>OPTION IS NOT APPLICABLE TO THIS MODEL</b></p> <p><b>Sub-menu</b>                  3 PICS                  4 PICS                  5 PICS (DEFAULT)                  ...                    10 PICS</p>
<b>DEFALT</b>	<b>RESET FACTORY DEFAULTS</b>
	<p><b>Sub-menu</b>                  ALL        Erases all programmed devices and defaults all options                  OPTION    Defaults all option values except radio keys and radio devices                  KEY        Erases all radio keys                  SENSOR    Erases all radio detectors and defaults SENSOR 1 (main PIR)</p> <p>Erase devices and/or default options as required.                  If ALL or KEY is selected, GUARDPOST will jump to the start of PROGRAM mode, displaying LEARN / KEY 1.</p>
<b>P-EXIT</b>	<b>EXIT PROGRAM MODE</b>
	<p>When P-EXIT is displayed on the programming menu, press the ON button on a valid radio key to exit program mode.</p>

## PROGRAMMING OPTIONS SUMMARY (ALL)

Program Option Name	SMS Program Option No. (XX)	Value (YY)	Description	Default	Page No.
KEY 1-23	N/A	KEY, DURESS, MEDIC, BELL, NO PAN, ERASE	Options for learning radio keys	None	18
SENS 1	N/A	ALARM, HOME, HOME 2, FIRE, CHIME, ACHIME, HCHIME, H2CHIM, SILENT, EXCLUD	Options for the onboard sensor	ALARM	
SENS 2-23	N/A	ALARM, HOME, HOME 2, FIRE, CHIME, ACHIME, HCHIME, H2CHIM, SILENT, EXCLUD	Options for the optional radio devices 2-23	ALARM	
RANGE	01	00, 01	Onboard PIR range. 00 = Low, 01 = High	LOW	19
PULSE	02	01, 02, 03, 04	Onboard PIR pulse count.	1 PULS	
SIGNAL	N/A	–	Radio devices signal strength check	–	
RADJAM	N/A	ON, OFF, SILENT	Radio jamming alarm	OFF	
RADSUB	N/A	ON, OFF	Radio message substitution alarm	OFF	
SUPVIS	03	00, 01, 04, 08, 16, 24	Supervision time in hours. 00 = Supervision disabled	OFF	
LOKOUT	04	00	Alarm Lockout. 00 = Disabled, 01 = Enabled	OFF	20
ENTRY	05	05, 10, 15, 20, 25, 30	Entry delay in seconds	5 sec	
EXIT	06	05, 10, 15, 20, 25, 30, 35, 40, 45, 50, 55, 60	Exit delay in seconds	5 sec	
SIREN	07	01, 02, 03, 04, 05	Siren time in minutes	5 min	
CHIRPS	08	00, 01	External Siren Chirps. 00 = Disabled, 01 = Enabled	ON	
V-ARM	N/A	ON, OFF	Voice annunciation for arming/disarming	ON	
V-ALRM	N/A	ON, OFF	Voice annunciation for alarms	ON	
V-BATT	N/A	ON, OFF	Voice annunciation for battery alarms	ON	
V-FALT	N/A	ON, OFF	Voice annunciation for system faults	ON	
OPEN	09	00, 01, 02, 03*	Open Close Reports. 00 = Disabled, 01 = ON, 02 = RESTOR*, 03 = RES+OC*	OFF	
LOWBAT*	10	00, 01, 02, 03	Low Battery Reporting. 00 = NONE, 01 = MAIN, 02 = SENSOR, 03 = ALL	NONE	21
CLIENT	CL1	Up to 4 digits	Client account number	0000	
PHONE 1	PH1	Up to 20 digits	Telephone No. 1 for reporting alarms by CID, SMS or AUD	none	
PHONE 2	PH2	Up to 20 digits	Telephone No. 2 for reporting alarms by CID, SMS or AUD	none	
GSM SG	N/A	–	Indicates GSM signal strength 0=no signal, 9=best signal		
ABORT	11	00, 05, 10, 15, 20, 25, 30, 35, 40, 45, 50, 55, 60	Dialler Abort delay in seconds.	5 sec	
MEDIC	12	00, 05, 10, 15, 20, 25, 30, 35, 40, 45, 50, 55, 60	Medical Key Abort delay in seconds.	20 sec	
T-CALL*	13	00, 01, 07, 14, 30	Test Call interval in days. 00=Test Calls disabled	OFF (7 DAY when dialler = CID)	23
DIALER	14	00, 01, 02	Dialler reporting format 00 = Contact ID (CID), 01 = SMS, 02 = Audible	CID	
POWER	15	01, 02, 03, 04, 05, 06, 07, 08	01 = BATT, 02 = BAT-30, 03 = BAT-1H, 04 = BAT-2H, 05 = AC-ON, 06 = SLR-30, 07 = SLR-1H, 08 = SLR-2H	BATT	
CAMERA		OPTION IS NOT APPLICABLE TO THIS MODEL			
PICS		OPTION IS NOT APPLICABLE TO THIS MODEL			25
DEFAULT	N/A	ALL, OPTION, KEY, SENSOR	Reset factory defaults	N/A	
P-EXIT	N/A	–	Press the ON button on your radio key to exit program mode.	N/A	
Only available by SMS	V		Request current programmed options. Guardpost replies with the current values of all programmed options	N/A	–

\* Note. Test Calls, Low Bat & Restorals are reported only by Contact ID and are **not** sent via SMS or Audible format.

Options numbers marked "N/A" are not available for programming by SMS.

See page 28 for a version of this options summary showing only SMS programming options.

## PROGRAMMING BY SMS



GSM  
SMS  
Programming



Many Guardpost programming options can be programmed remotely by SMS message. Some programming can only be performed locally by radio key.

To program a Guardpost by SMS you must know the mobile phone number of the Guardpost's SIM card and the client account number.

### NOTES

- SMS programming commands must not include spaces.
- Some commands must be sent in uppercase.
- The dialler must be enabled to allow programming by SMS.
- SMS reply messages are sent to the mobile phone which sent the SMS commands - which can be any mobile phone.

**IMPORTANT NOTE.**  
Guardpost may not respond to SMS commands immediately if the GSM module is sleep mode. The state of the GSM module is dependent on the power management mode. See page 24.

## SMS PROGRAMMING COMMANDS

SMS programming commands are sent to the Guardpost in this format:

**CCCC,PXX=YY,E**

CCCC	Client account number	4 digits
P	Precedes each program option 01 to 15 Not required for PH1, PH2 & CL1	Must be UPPERCASE
XX	Program option number	01 - 15, PH1, PH2, CL1
YY	Value	
E	End of message	Must be UPPERCASE

The Guardpost will reply with a confirmation SMS:

Unit CCCC: PXX=YY, Programmed

If you send an SMS in the wrong format, Guardpost will respond with:

Unit CCCC: Command error.

The SMS format requires a comma between each command and no spaces.

## PROGRAMMING BY SMS



GSM  
SMS  
Programming



### EXAMPLES

**To program ENTRY delay to be 10 seconds.** In these examples the Guardpost's client account number is 1234:

Send this SMS to the Guardpost `1234,P05=10,E`

Guardpost will reply with `Unit 1234: P05=10, programmed`

**Up to 7 general programming options can be programmed in one SMS message.** (PH1, PH2 and CL1 must be sent separately.)

For example:

To program multiple options in one message `1234,P05=10,P06=20,P08=01,E`

Guardpost will reply with `Unit 1234: P05=10,P06=20,P08=01, programmed`

**To program example PHONE1 to be 9123 1234.**

Send this SMS to the Guardpost `1234,PH1=91231234,E`

Guardpost will reply with `Unit 1234: PH1=91231234, programmed`

**To program example PHONE1 to be 9123 1234 and PHONE2 to be 92220011.**

Send this SMS to the Guardpost `1234,PH1=91231234,PH2=92220011,E`

Guardpost will reply with `Unit 1234: PH1=91231234,PH2=92220011, programmed`

**To program example CLIENT account number to be 2468.**

Send this SMS to the Guardpost `1234,CL1=2468,E`

Guardpost will reply with `Unit 1234: CL1=2468, programmed`

**To delete PHONE1.**

Send this SMS to the Guardpost `1234,PH1=-,E`

Guardpost will reply with `Unit 1234: PH1=, programmed`

**To request a summary of all current program options.**

Send this SMS to the Guardpost `1234,V,E`

Guardpost will reply with `Unit 1234: P01=00,P02=03,  
P03=24,P04=00,P05=05,P06=05,  
P07=05,P08=01,P09=00,P10=00,  
P11=00,P12=20,P13=07,P14=01,  
P15=01,PH1=91231234,PH2=.....`

#### NOTES

- SMS programming messages must not include spaces.
- Some commands must be sent in uppercase.
- Up to 7 options can be sent in one SMS message.
- To delete a phone number, send a hyphen '-' in place of a phone number.
- SMS acknowledgement messages are sent to the mobile phone which sent the SMS commands - which can be any mobile number. However if PHONE 1 or PHONE 2 are blank the dialler will not send messages of any type.

## PROGRAMMING BY SMS

### SMS PROGRAM OPTIONS SUMMARY

These options are available for programming by SMS. See page 26 for the full programming options table.

Program Option Name	SMS Program Option No. (XX)	Value (YY)	Description	Default	Page No.
RANGE	01	00, 01	Onboard PIR range. 00 = Low, 01 = High	LOW	19
PULSE	02	01, 02, 03, 04	Onboard PIR pulse count.	1 PULS	
SUPVIS	03	00, 01, 04, 08, 16, 24	Supervision time in hours. 00 = Supervision disabled	OFF	
LOKOUT	04	00	Alarm Lockout. 00 = Disabled, 01 = Enabled	OFF	20
ENTRY	05	05, 10, 15, 20, 25, 30	Entry delay in seconds	5 sec	
EXIT	06	05, 10, 15, 20, 25, 30, 35, 40, 45, 50, 55, 60	Exit delay in seconds	5 sec	
SIREN	07	01, 02, 03, 04, 05	Siren time in minutes	5 min	
CHIRPS	08	00, 01	External Siren Chirps. 00 = Disabled, 01 = Enabled	ON	
OPEN	09	00, 01, 02, 03*	Open Close Reports. 00 = Disabled, 01 = ON, 02 = RESTOR*, 03 = RES+OC*	OFF	21
LOWBAT*	10	00, 01, 02, 03	Low Battery Reporting. 00 = NONE, 01 = MAIN, 02 = SENSOR, 03 = ALL	NONE	
ABORT	11	00, 05, 10, 15, 20, 25, 30, 35, 40, 45, 50, 55, 60	Dialler Abort delay in seconds.	5 sec	22
MEDIC	12	00, 05, 10, 15, 20, 25, 30, 35, 40, 45, 50, 55, 60	Medical Key Abort delay in seconds.	20 sec	23
T-CALL*	13	00, 01, 07, 14, 30	Test Call interval in days. 00=Test Calls disabled	OFF (7 DAY when dialler = CID)	
DIALER	14	00, 01, 02	Dialler reporting format 00 = Contact ID (CID), 01 = SMS, 02 = Audible	CID	
POWER	15	01, 02, 03, 04, 05, 06, 07, 08	01 = BATT, 02 = BAT-30, 03 = BAT-1H, 04 = BAT-2H, 05 = AC-ON, 06 = SLR-30, 07 = SLR-1H, 08 = SLR-2H	BATT	24
CLIENT	CL1	Up to 4 digits	Client account number	0000	21
PHONE 1	PH1	Up to 20 digits	Telephone No. 1 for reporting alarms by CID, SMS or AUD	none	22
PHONE 2	PH2	Up to 20 digits	Telephone No. 2 for reporting alarms by CID, SMS or AUD	none	
Only available by SMS	V		Request current programmed options. Guardpost replies with the current values of all programmed options	N/A	-

\* Note. Test Calls, Low Bat & Restorals are reported only by Contact ID and are **not** sent via SMS or Audible format.

## CENTRAL STATION REPORTING OPERATION



If enabled, Guardpost reports alarms to a central monitoring station via the GSM network in Contact ID format.

There are 2 phone numbers, a primary number PHONE1 and a secondary number PHONE2. Reports are usually sent on the primary number but if the dialler is unsuccessful in connecting, it will dial the secondary number.

A client account number is allocated by the monitoring company to identify the customer. The client account number must be programmed into the system.

GUARDPOST transmits the next message on the queue, and if no acknowledge is received from the monitoring station, GUARDPOST re-transmits the message for a total of 10 attempts before displaying a dialler fault. Then, it will try again in 5 minutes, then, another 4 times every 1 hour. If still unsuccessful, GUARDPOST ceases transmitting until a new event occurs and raises a system alarm.

## CONTACT ID REPORTING FORMAT

Contact ID reporting format takes the form:

**SSSS 18 Q XYZ GG CCC E**

SSSS	4 digit Client Account number
18	Uniquely identifies this format as Contact ID
Q	Event qualifier (1 = New alarm or Open; 3 = Restore or Close)
XYZ	Event code (hexadecimal)
GG	Group code. (always 00)
CCC	Sensor/key ID + offset, or Type number (decimal)
E	Error check

## CONTACT ID REPORTING TABLE

Program Option	Event Code (XYZ)	Offset + device ID, or Type number (CCC)
SENS 1-23 = ALARM SENS 1-23 = HOME SENS 1-23 = HOME 2 SENS 1-23 = ACHIME SENS 1-23 = HCHIME	130 Burglary	0 + ID
SENS 1-23 = FIRE	133 24 hour	50 + ID
Always enabled (unless auto-excluded at power-up)	137 Siren box tamper (Main unit)	106
Always enabled	383 Tamper (Sensor)	350 + ID
KEY 1-23 = KEY	120 Panic by user	300 + ID
KEY 1-23 = DURESS	121 Duress by user	400 + ID
KEY 1-23 = MEDICAL	101 Medical pendant	650 + ID
RADJAM = ON or		
RADSUB = ON	355 Radio jamming	105
SUPVIS not = OFF	355 Radio supervision poll fail (Device)	200 + ID Detector
500 + ID Fixed Panic Button		
LOWBAT = MAIN LOWBAT = ALL	302 Main unit low battery	107
LOWBAT = SENSOR LOWBAT = ALL	384 Radio device low battery	0 + ID
Always enabled	309 Main unit battery test fail	108
OPEN = ON	401 Open/Close with user ID	0 + ID
Always enabled	406 Cancel of alarm message	0 + ID

---

## SMS REPORTING OPERATION



GSM  
SMS Message



If enabled, Guardpost reports alarms by SMS to up to two mobile phones via the GSM network.

There are 2 phone numbers, a primary number PHONE1 and a secondary number PHONE2.

Guardpost will send an SMS to PHONE1 and PHONE2 if the phone number is programmed.

---

## SMS REPORTING FORMAT

Unit [Client number]: [Alarm event]

Example

Unit 1234: Alarm sensor 1

This means Guardpost with the client account number 1234 an alarm from sensor 1.

---

## SMS REPORTING TABLE

Client Number (yyyy)	Event Message	Device ID (xx)	Description
0000 – FFFF	Alarm sensor	1 – 23	Alarm triggered by sensor xx from unit yyyy
0000 – FFFF	Siren tamper	N.A.	Alarm triggered by Siren box tamper from unit yyyy
0000 – FFFF	Tamper sensor	1 – 23	Alarm triggered by sensor xx tamper from unit yyyy
0000 – FFFF	Panic key	1 – 23	Panic alarm triggered by key xx from unit yyyy
0000 – FFFF	Duress key	1 – 23	Duress alarm triggered by key xx from unit yyyy
0000 – FFFF	Medical key	1 – 23	Medical alarm triggered by key xx from unit yyyy

---

## AUDIBLE REPORTING OPERATION



If enabled, Guardpost reports alarms by audible message to up to two telephones via the GSM network.

### Audible Report

Guardpost is able to report alarms to one or two telephone/mobile phones via the GSM network with audible messages, such as “ALARM FROM SENSOR ONE”, “MEDICAL ALARM KEY TWO”, “PANIC ALARM KEY THREE” etc. Multiple voice messages will be played if more than one event occurs while reporting.

There are 2 phone numbers, a primary number PHONE1 and a secondary number PHONE2. Reports are usually sent on the primary number but if the dialler report is not acknowledged, it will dial the secondary number. Telephone numbers must be programmed into the system.

If no acknowledge is received from the number called, GUARDPOST re-try for a total of 10 attempts before displaying a dialler fault. Then, it will try again in 5 minutes, then, another 4 times every 1 hour. If still unsuccessful, GUARDPOST ceases transmitting until a new event occurs and raises a system alarm.

### ACKNOWLEDGE

Press key '9' on the receiving telephone to acknowledge the audible report. Guardpost will then hang up the call.

Or press “\*” to acknowledge the audible report and start Two-Way-Voice monitoring. See page 32, Two Way Voice Monitoring.

## TWO-WAY-VOICE MONITORING



### TWO-WAY-VOICE TIMING

- 3 minutes time out for call back after dialler report has finished
- 90 seconds time out for phone key commands after a call has been connected.
- A Two Way Voice communications session will time out after 3 minutes.
- Multiple call back is allowed within 90 seconds after a call has been terminated using "99".

Guardpost Two-Way-Voice (TWV) monitoring via GSM allows an operator or customer to listen and talk to Guardpost when alarm events happen.

Communications at the Guardpost is via the built-in microphone and speaker.

When an alarm event occurs and dialler report ends, or, when Two-Way-Voice is enabled via SMS, the operator/customer can start two-way-voice monitoring to listen to the area in which Guardpost is installed.

The operator can conduct a two way voice conversation with the premises. No user intervention is required at the Guardpost and all communications is "hands-free".

Two-Way-Voice monitoring can be initiated by one of three methods.

### DIRECT START AFTER EVENT

Direct start of Two-Way-Voice monitoring can only be used if GSM audible reporting is enabled (GSMAUD).

While the Guardpost voice message is annunciating, press **[\*]** (star) on your phone to acknowledge the audible report. This will start Two-Way-Voice monitoring in listen mode.

### CALL BACK AFTER EVENT

You can always phone the Guardpost to start Two-Way-Voice monitoring after a dialler report has ended in any GSM dialler mode (GSMCID, GSMSMS and GSMAUD).

- 1 Call back the Guardpost after a dialler report has finished. Continuous beeps will be heard indicating that Two-Way-Voice is ready to start.
- 2 Press **[\*][\*]** on your phone to start Two-Way-Voice in listen mode.

### CALL BACK ENABLED BY SMS

This method of initiating Two Way Voice requires an SMS request to be sent to the Guardpost. In this example the Guardpost's client account number is 1234.

- 1 Send this SMS to the Guardpost **1234,TWV Request** T must be uppercase. (Shortcut. You can omit "WV Request" and send only 1234,T)  
Guardpost will reply with **Unit 1234: TWV Enabled**
- 2 Once you receive the SMS reply you have 3 minutes to phone the Guardpost and start two-way-voice communications.. Continuous beeps will be heard indicating that Two-Way-Voice is ready to start.
- 3 Press **[\*][\*]** on your phone to start Two-Way-Voice in listen mode.

### TELEPHONE COMMANDS

Press **[\*][\*]** to start TWV.

Press **[\*]** to acknowledge an Audible alarm report.

### TELEPHONE COMMANDS DURING A TWO-WAY-VOICE SESSION.

Press **[1]** to talk

Press **[2]** to listen

Press **[7]** to reset/extend time. (Two Way Voice times out after 3 minutes.)

Press **[3]** to increase Guardpost microphone gain

Press **[6]** to decrease Guardpost microphone gain

Press **[9][9]** to hang up

### REMOTE ARM/DISARM DURING TWO-WAY-VOICE

The Guardpost can be remotely armed/disarmed during a two way voice session.

Press **[8][#]** to arm

Press **[0][#]** to disarm

"Armed" or "Disarmed" will be heard then two-way-voice will continue in LISTEN mode.

An attempt to arm/disarm the panel when it is already armed or disarmed will result in 2 seconds silence then two-way-voice will continue in LISTEN mode.

## RADIO SIREN OPTION

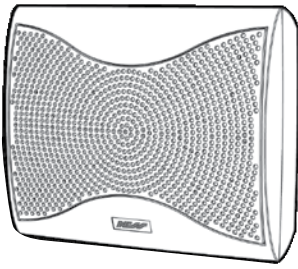

Guardpost has onboard support for the optional Ness Radio Siren.

### RADIO SIREN PROGRAMMING

Guardpost will send a radio siren learn message when you manually exit Guardpost program mode.

To Program Guardpost to a radio siren.

- 1** Power up the Guardpost and press your radio key OFF button until the Guardpost display shows P-EXIT. Press no other keys at this stage.
- 2** Power up the radio siren with tamper unsealed. The radio siren is now in Learn mode.  
*Proceed to the next step immediately as the radio siren will only remain in Learn mode for 30 seconds.*
- 3** Press your radio key ON button. This will exit Guardpost program mode and automatically send a Learn signal to the radio siren.  
*The radio siren will chirp chirp + double chirp if the Guardpost has successfully been enrolled.*

### NOTES

- When it is in Learn mode the radio siren will enrol any valid Ness transmitter.  
It is recommended that during this programming procedure the batteries should be removed from all Ness devices which might send an unwanted radio signal.

### OPERATION

When an alarm event starts the Guardpost siren, Guardpost also sends an “ON” message to the Radio Siren.

When the Guardpost’s siren times out, Guardpost sends an “OFF” message to the Radio Siren.

## DIALLER LISTEN-IN FUNCTION



The “Dialler Listen-in ” feature is a useful installer’s tool for diagnosing dialler operation in Contact ID reporting mode.

To enable dialler listen-in press the left front panel control button for 2 seconds.

Listen-in will be enabled for 3 minutes.

Dialler communications will be heard from the internal speaker.

Note: Ignore the display/voice of VOLUME while holding left button.

## DIALLER SWINGER SHUTDOWN

To prevent excessive calls charges in the event of repeated alarms, dialler alarm reports are limited to a maximum of 20 reports between Arm/Disarm, or a 24 hour period.

In addition, the runaway shutdown feature limits the number of times an alarm from a particular device will be sent to the monitoring station. After 3 alarms have been sent, no further alarms for that device will be sent until the system is Disarmed and Armed.

This applies to all reporting formats - Contact ID, SMS and Audible.

## TROUBLESHOOTING

ERROR CODE OR SYMPTOMS	POSSIBLE CAUSE(S)	SOLUTION
DIALER SIM FAULT	SIM related faults such as: <ul style="list-style-type: none"> <li>• SIM not inserted or inserted properly.</li> <li>• SIM is locked with a pin.</li> <li>• SIM is not registered.</li> <li>• SIM has no credit to make/receive calls.</li> </ul>	<ul style="list-style-type: none"> <li>• Insert SIM</li> <li>• Check the SIM operation by testing it in a mobile phone handset.</li> </ul>
DIALER MODULE FAULT	GSM module related issues such as <ul style="list-style-type: none"> <li>• GSM signal is too low.</li> <li>• Network related failure.</li> <li>• Communication issues between GSM module and the panel.</li> </ul>	<ul style="list-style-type: none"> <li>• Check GSM signal strength - make sure it is greater than level 2.</li> <li>• Check the network coverage by testing the SIM in a mobile handset.</li> </ul>
DIALER FAIL	<ul style="list-style-type: none"> <li>• Dialler report was not delivered</li> <li>• Dialler report did not get acknowledged, Example:</li> <li>• An audible message was not acknowledged after reporting 10 times.</li> </ul>	<ul style="list-style-type: none"> <li>• Reset the unit using the override key or trigger and acknowledge a new alarm.</li> </ul>
ARM/DISARM OR PROGRAM BY SMS NOT WORKING	<ul style="list-style-type: none"> <li>• SIM unable to receive SMS.</li> <li>• SIM is full or with many messages.</li> <li>• All dialler functions including operation by SMS is disabled if PHONE 1 and PHONE 2 are blank.</li> </ul>	<ul style="list-style-type: none"> <li>• Check that the SIM card can receive SMS by testing it in a handset.</li> <li>• Make sure all messages on the SIM card are deleted.</li> <li>• Make sure PHONE 1 or PHONE 2 are programmed.</li> </ul>
SMS NOT REPORTING	<ul style="list-style-type: none"> <li>• SIM unable to send SMS.</li> <li>• All dialler functions are disabled if PHONE 1 and PHONE 2 are blank.</li> <li>• Only main alarm events are reported by SMS. Alarms reported are: Sensor Alarm/Tamper, Siren Tamper Key Panic/Duress/Medical.</li> </ul>	<ul style="list-style-type: none"> <li>• Check that the SIM card can send SMS by testing it in a handset.</li> <li>• Make sure PHONE 1 or PHONE 2 are programmed.</li> </ul>
AUDIBLE NOT REPORTING	<ul style="list-style-type: none"> <li>• SIM unable to call a number.</li> <li>• Only main alarm events are reported by Audible. Alarms reported are: Sensor Alarm/Tamper, Siren Tamper Key Panic/Duress/Medical.</li> </ul>	<ul style="list-style-type: none"> <li>• Check that the SIM card can make calls by testing it in a handset.</li> </ul>
RADIO SIREN NOT WORKING	<ul style="list-style-type: none"> <li>• Guardpost not enrolled with Radio Siren.</li> </ul>	<ul style="list-style-type: none"> <li>• Make sure Guardpost is programmed into radio siren.</li> </ul>
RADIO SIREN BEHAVIOUR IS NOT NORMAL	<ul style="list-style-type: none"> <li>• Guardpost not enrolled with Radio Siren, but other radio devices have been enrolled.</li> </ul>	<ul style="list-style-type: none"> <li>• Make sure Guardpost is programmed into radio siren.</li> <li>• Make sure no other device other than Guardpost is programmed into radio siren</li> <li>• Erase all other devices and reprogram Guardpost into radio siren.</li> </ul>
TEST ALARM NOT WORKING	<ul style="list-style-type: none"> <li>• The test alarm created is too short.</li> </ul>	<ul style="list-style-type: none"> <li>• Give abort time to expire before disarming</li> <li>• Connect mains power or set power mode to mains.</li> </ul>
SENSOR FAIL	<ul style="list-style-type: none"> <li>• Radio sensor faulty.</li> <li>• Radio sensor battery abnormally low or faulty.</li> <li>• Supervision time too short.</li> </ul>	<ul style="list-style-type: none"> <li>• Test sensor operation.</li> <li>• Adjust supervision time.</li> </ul>

## SPECIFICATIONS

SYSTEM	
ONBOARD PIR	15m PIR motion sensor
ONBOARD SIREN	124dBm
GSM/3G DIALLER SUPPORTED BANDS	GSM: 850, 900, 1800, 1900MHz 3G: 850, 2100MHz
BATTERY	12 Volt 3.2Ah SLA provides internal power in low-current modes / provides backup power in Mains mode
USER INTERFACE	
DISPLAY	6 Character scrolling LED
VOICE FEEDBACK	Onboard voice + language options
OPERATION	Arm / Disarm / Panic / Programming by radio keys Arm / Disarm by SMS messaging
EVENT LOG	Last 5 events with voice announcement
SETUP	
SYSTEM PROGRAMMING	Local programming by radio keys Self learning of radio devices by local programming Off site programming by SMS messaging
RADIO DEVICES	
DEVICES SUPPORTED	Up to 24 Ness Radio Keys or Radio Devices including the onboard PIR
RADIO SECURITY	Proprietary encryption and supervision Radio jamming detection Radio substitution detection
RADIO RX/TX	Ness integrated receiver for radio device signals Ness Radio Siren transmitter onboard
RADIO FREQUENCY	304Mhz / 868MHz depending on local requirements
INPUTS / OUTPUTS	
EXTERNAL WIRE LOOM	RED/BLACK. Strobe output: 12V strobe light, max. 2 RED/BLUE. Siren output: 8 Ohm horn speaker, max. 1 RED/WHITE. Internal siren output: 12V screamer, max. 1 YELLOW/GREEN. Tamper input: 3k3 end of line (resistor supplied)  RED/RED FLYING LEADS. External input for hardwired 17VAC supply or solar panel supply
EXTERNAL POWER	17VAC Plug Pack supplied for periodic battery charging or for full-time power External input for hardwired 17VAC supply, (see External Wire Loom) External input for solar panel power supply, (see External Wire Loom)
PHYSICAL	
DIMENSIONS, MAIN UNIT	515(h) x 112(w) x 80mm(d)
COMPLIANCE	
APPROVALS	C-TICK, CE