



Ness Smartbell IP Intercom

Turn your iPhone/Smart phone/Tablet into
Video & Audio Intercom



Installation and Users Manual

Index

Introduction	3
GENERAL PRECAUTIONS	5
System Configuration and Connections	5
Usability	7
Maximum Number of Devices	7
Home Screen of the Ness SmartBell INTERCOM on a Smart Device	8
Calling an Intercom Extension	9
Calling a iDevice or Android Device Extension	10
VISITOR LOG (Photo snap shot)	12
Smart Home	13
Monitoring the Camera on a Door Phone	14
SETUP	15
RINGTONE Settings	16
Background Settings.....	19
Modify Registration Message	20
Access Card Settings.....	21
Volume Settings.....	21
Version & Terminal equipment.....	22
Slideshow settings (only for Indoor Phone 101-132 (10" tablet)	22
Notes on CAT5e Cable	23
Installation Steps – Network & Wifi setting	24
Network connection Architecture.....	24
WiFi Router Setting.....	25
Setting up the eGateway for the first time	26
Installation steps – Device Installation	29
Installing the Outdoor Phone (ODP)	29
Outdoor Phone wire connection table.....	31
Connections to electronic door strike/lock	32
Door Strike Wiring Examples	32
Indoor Phone / Master Station, 10" tablet (101-132) installation	35
Installation steps – Device Pairing	38
Ness SmartBell eGateway Specifications	41
Outdoor Phone (ODP) / Door Unit - Device pairing to eGateway	42
Room Station / 10" tablet / Indoor Phone (101-132) pairing and setting flow	43
Device pairing of Room Station / 10" Indoor Phone to the eGateway	44
Main IP intercom application (App)	46
Initiate Wi-Fi setting.....	48
Android Smart Device pairing to the eGateway	48
Important Note Re WMM and Audio on some Smart phones	51
iOS Smart Device pairing to the eGateway	53
Mobile device pairing and setting flow chart	58
Use of STATIC IP addressing setting	59
Use of DHCP addressing settings	59
DDNS account application and setting	60
Set the DDNS to WiFi router	63
Outdoor Unit Settings	65
Outdoor Settings.....	65
Volume Control	66
Third Party Security System Integration	66
Third Party Integration Setting.....	67
Push Notification APNS	69
Testing Push Notifications	70
Remote Access	72
Troubleshooting (FAQs)	73
NOTES	73
Contact Us	74

Introduction

Thank you for selecting the Smartbell IP intercom for your communication and security needs. Please read this manual carefully before installation and keep it in a safe place for future reference.

The Ness SmartBell Intercom allows user to communicate to each other via the Ness SmartBell eGateway. Once a unit is programmed ('paired') into the eGateway they can communicate to any device that is also programmed to it. This includes Outdoor Phones, (also known as Door Stations), Indoor Phone (also known as Room Stations or 10" Tablet Room) or Smartphone's (Android or iOS (iPhone / iPad) devices.)).

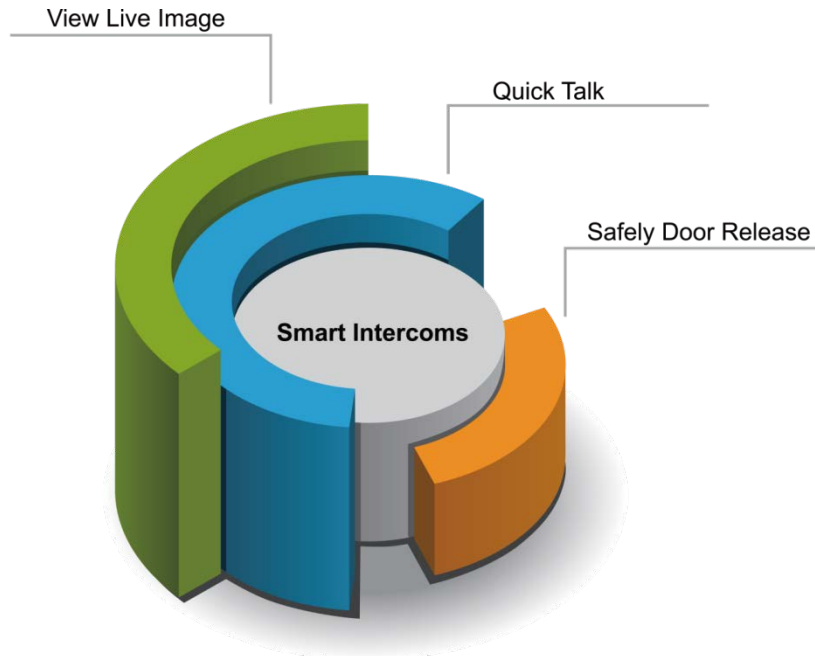

We need intercoms in daily life

- ✓ **Office Reception**
 - When away Office/Home, owner can monitor, view visitor image displayed to 3G Smart phone or Wi-Fi tablet.
- ✓ **Family member**
 - Quick talk and door release from anywhere.
- ✓ **Seniors at home**
 - Senior at home, one can view visitor image displayed to TV set.
 - Simply click on talk and communicate with door phone station.
 - Door release from safely inside building.
- ✓ **Hospital Nurse Call**
 - Duty station for communication with patient rooms.
 - View patient images displayed to Kiosk station.
 - When away from the duty station, view image displayed on a 3G Smart phone or Wi-Fi tablet, quick talk from anywhere.
- ✓ **Public service**
 - Situation image displayed to 3G Smart phone, Wi-Fi tablet, Kiosk station.
- ✓ **Unattended Assistance**
 - Listen to activity for secure, service calls, discreet monitoring from any offsite 3G Smart Phone, quick talk from anywhere.

Turn your Smart Phone into an intercom

- Turn Your Smart Phone/Tablet into intercoms
- Key features:
 - Control intercom on Wi-Fi/WAN networks.
 - Listen to activity for secure, discreet monitoring.
 - Quick door release from safely inside building or anywhere.
 - Simply click on Talk & Monitor to communicate with door phone station.

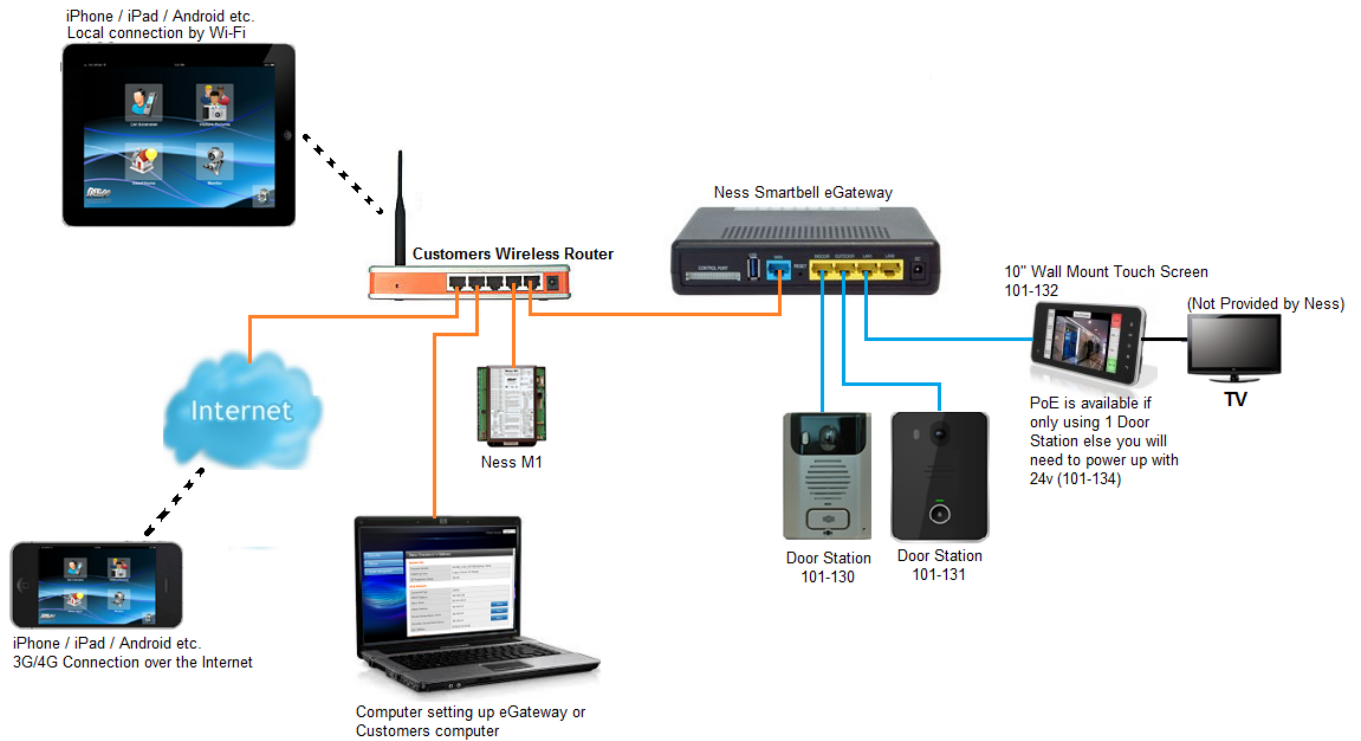



GENERAL PRECAUTIONS

- ▶ Keep the unit more than 1 m (3.3') away from radio or TV.
- ▶ Keep the intercom wires more than 30cm (12") away from AC100-240V wiring. AC induced noise and/or unit malfunction could result.
- ▶ Install the unit in an area that will be accessible for future inspections, repairs, and maintenance.
- ▶ As to other manufacturer's devices (such as door releases) used with this system, comply with the Specifications and Warranty conditions that the manufacturers or venders present.
- ▶ If the unit is down or does not operate properly, unplug the power supply.
- ▶ The unit can be damaged if dropped. Handle with care.
- ▶ The unit turns inoperative during power failure.
- ▶ In areas where broadcasting station antennas are close by, the intercom system may be affected by radio frequency interference.
- ▶ All the units are designed for indoor use only. Do not use outdoor.
- ▶ This product, being a control unit of door release, should not be used as a crime prevention device.
- ▶ It must be noted in advance that the LCD panel, though manufactured with very high precision techniques, inevitably will have a very small portion of its picture elements always lit or not lit at all. This is not considered a unit malfunction.
- ▶ Door station is not weather-resistant, and do not spray with high pressure water. Unit trouble could result.
- ▶ For wiring, specify CAT5e straight cable.
- ▶ Due to the environmental sound around the unit, it may hinder smooth communication, but this is not a malfunction.
- ▶ When outside temperature lowers sharply after rainfall, etc., the inside of camera may fog up slightly, causing a blurry picture, but this is not a malfunction. Normal operation will be restored when moisture evaporates.
- ▶ Do not locate the units in a location with restricted access. It impedes maintenance inspection or repairs. Also, unit trouble could result.
- ▶ If the wrong power supply is used it could damage the product(s) and will void your warranty on the product.



System Configuration and Connections

- ▶ The system is a video intercom system especially designed for applications in facilities such as office buildings, factories, schools, hospitals.
- ▶ Installed separately from conventional general-purpose internal communications systems, the system can be used as:
 - a video door entry system,
 - emergency announcement system,
 - rescue assistance system, urgent call system,
 - public announcement system, and access control system.
- ▶ The system can be constructed on an IP network so multiple sites of system can be connected and controlled as a global system. You can design the system to any scale depending on your needs.

Notice



- ▶ We will under no conditions be liable for:
 - Damage that occurs due to failures in network equipment; failures due to internet providers and cell phone companies; failures such as disconnected lines and other losses in communication, which render it impossible to provide this service or in any way delay this service due to causes outside of our responsibility; or if an error or missing data occurs during transmission.
 - Damage that occurs due to the inability to communicate due to malfunctions, problems, or operational errors in this product.
 - Damage caused if a customer's password or transmitted information are leaked through bugging or unlawful computer access over Internet communication.
 - Any damages or losses resulting from this product's contents or specifications.
 - Damage caused by the installer or customer powering up the unit with the wrong power supply. It's the installers responsibly to double check to ensure the correct power supply is being used.

- ▶ Please note that:
 - Images depicted in this manual may differ from the actual images.
 - This manual may be revised or changed without prior notice.
 - Product specifications may be changed for the sake of improvement without prior notice.
 - It is the customer's responsibility to ensure that their computer is secure. We will under no conditions be liable for security failures.

- ▶ This system is not intended for life support or crime prevention.

- ▶ It is just a supplementary means of conveying information. We will under no conditions be liable for loss of life or property which occurs while the system is being operated.

- ▶ It is up to the customer to ensure that there ISP does not block ports and that they are able to open DMZ in there router for remote access if required. Ness will not support and will not open ports for customers if they are unsure on how to do it, and customers will need to talk directly to their ISP for help and further information.

Usability

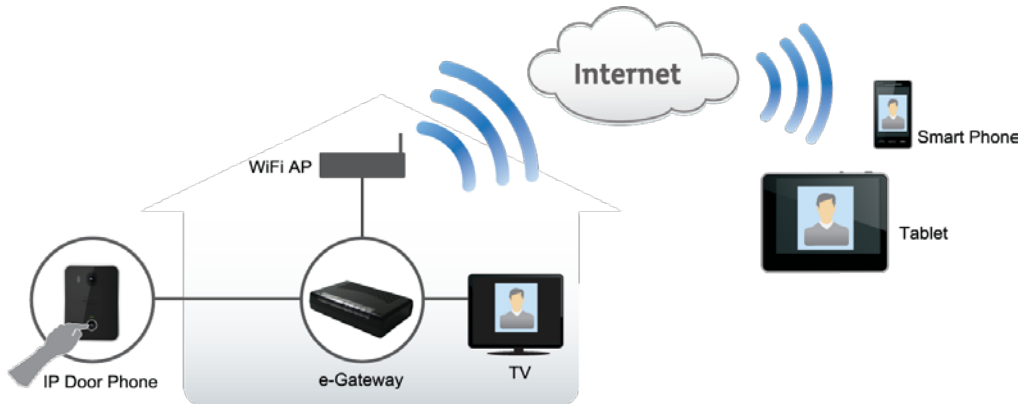

- ▶ Scenarios:
 - Visitor presses door phone, Image displayed to TV.
 - Owner listen to activity for secure, discreet monitoring.
 - Click on Talk & Monitor to communicate with door phone.
 - Quick door release from safely inside building or anywhere.

- ▶ Connectivity:
 - Easy installation and maintenance free.
 - Control intercom on Wi-Fi/WAN networks.
 - Accessible in anywhere via the internet and 3G connectivity.
 - Applicable in multi OS (iOS, Android, Windows) with mobile devices(Smart phone & tablet).

Maximum Number of Devices



Home Screen of the Ness SmartBell INTERCOM on a Smart Device



Calling an Intercom Extension

Press the **Call Extension** button from the home screen and tap on the extension you which to call.

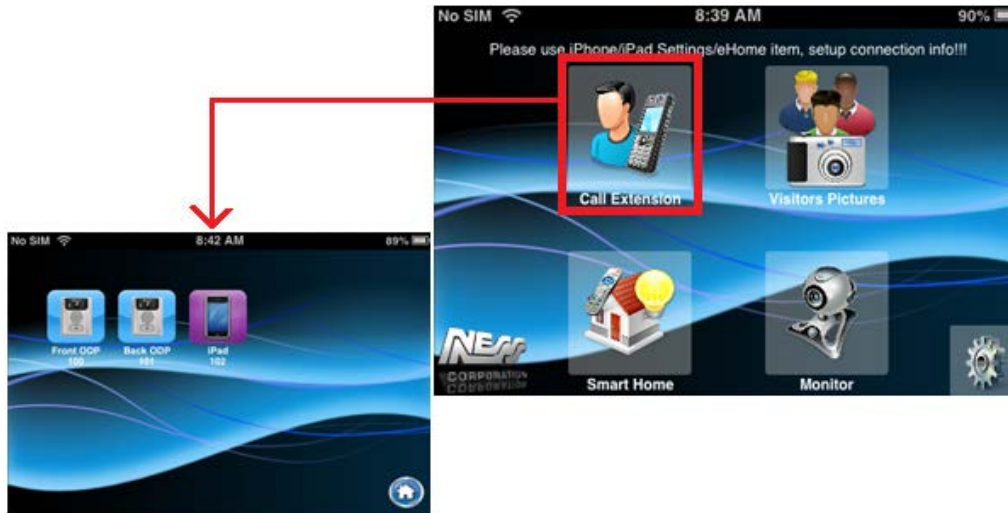

- Call intercom extension – is an audio only intercom
- Video is not applicable in this version.

NOTE: Video is only available when communicating with an Outdoor Phone / Door station.

When calling an Outdoor phone station from the list the following screen will appear:

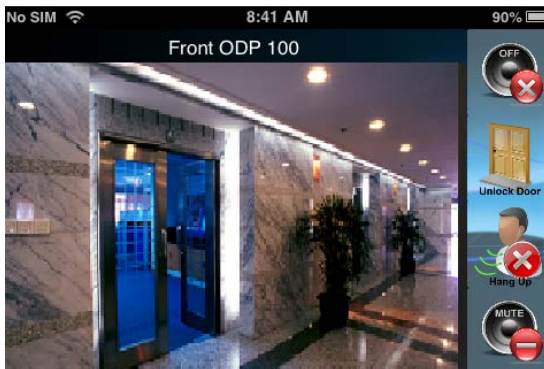

Switch between hands free speaker and handset speaker

Unlock the door

End / Hang Up the call

Mute Microphone on Smart Device

Calling a iDevice or Android Device Extension

Tap on the icon to call an iDevice or Android device and the call will begin.

Pressing the hang up button will end the call.



iDevice Started Call

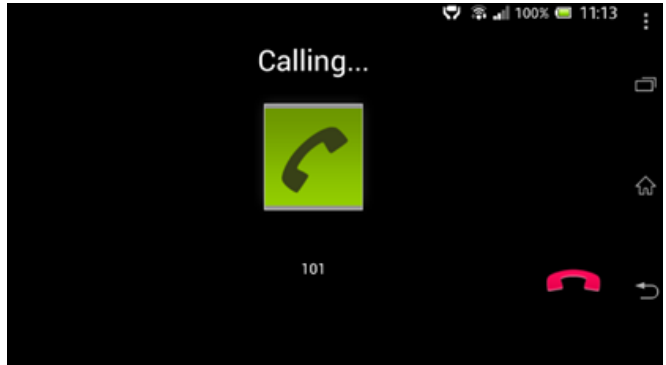

Android Device started call

The person at the receiving end of the call will be notified of the incoming call as shown below. If you want to reject the call you can just press the red phone icon. To answer the call press the green phone icon.

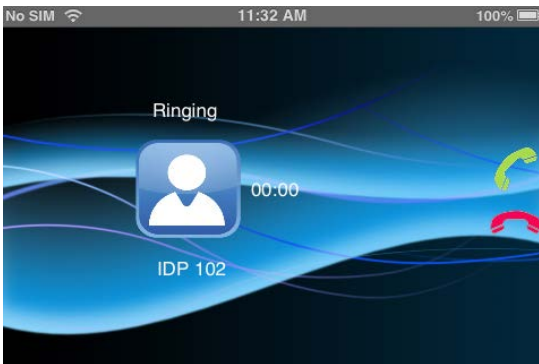

iDevice Ringing

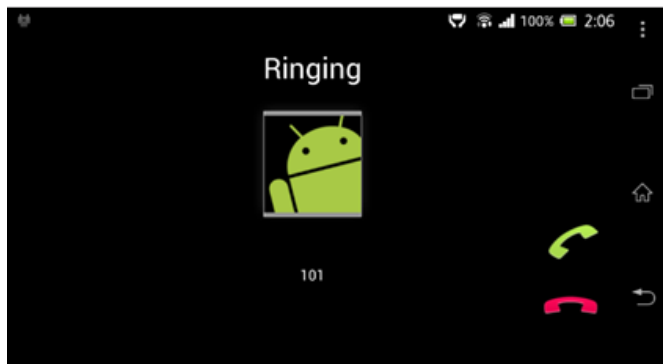

Android Device Ringing

On Apple Devices if the app is closed, or the screen is turned off then a Push Notification will show telling you have an incoming call from another device (or someone has pressed the door bell button).

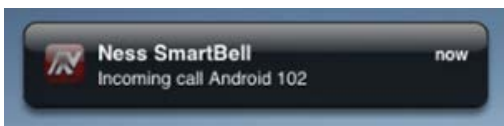

Tap on this notification and the app will then display and the incoming call will ring within in the app allowing you to answer it.

Once call has been made the following screen will display.

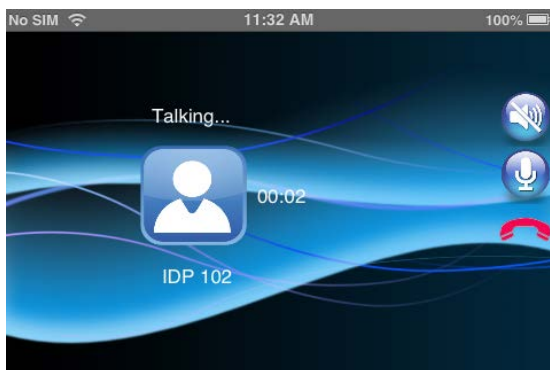

iDevice In a Call

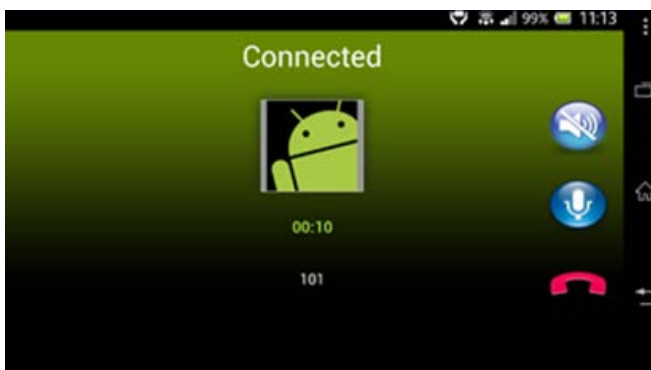

Android Device In a Call



By pressing this icon, it will mute the sound coming from the other person.



By pressing this icon, it will mute your microphone and the other person won't be able to hear you.



To end the call press the red hang up button.

VISITOR LOG (Photo snap shot)

Whenever a visitor comes to an outdoor phone it will take a series of snap shot images (typically 5) and store them so you can view for later viewing.

Click on “Visitor Log” from the main screen to view the most recent visitors.

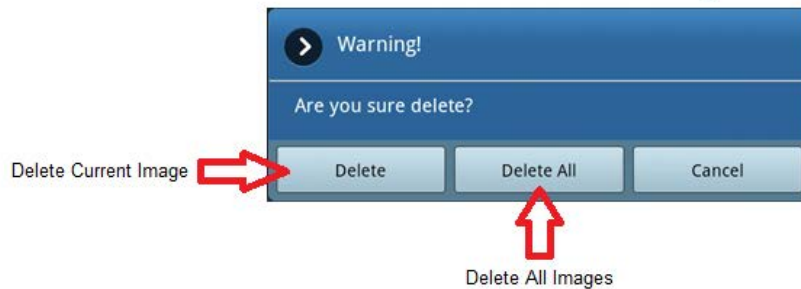

Smart Home

Press the **Smart Home** button from the home screen will launch the Push Controls App allowing you to control your AV devices.

Note: This feature is not available on the 10 inch Indoor Phone Touch Screen.

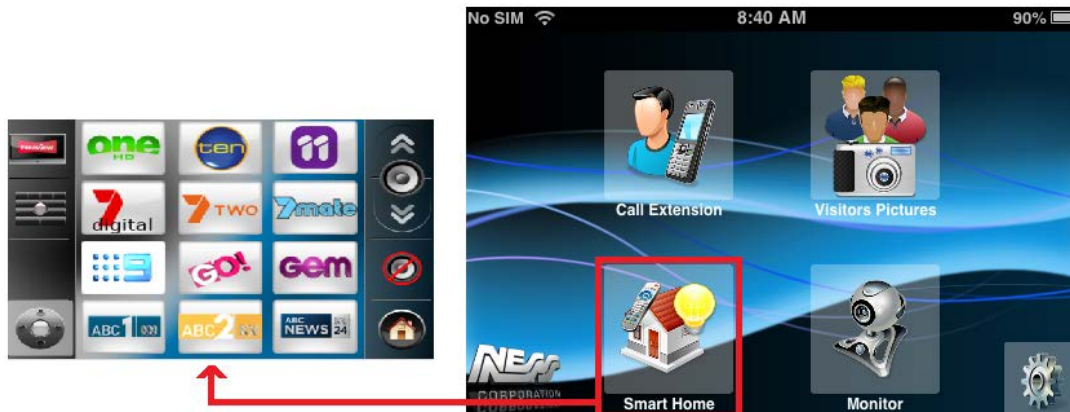

In the Push Project Editor you need to ensure you have a page called **home** (All lower case) as this is the page that the Ness Smartbell will open.

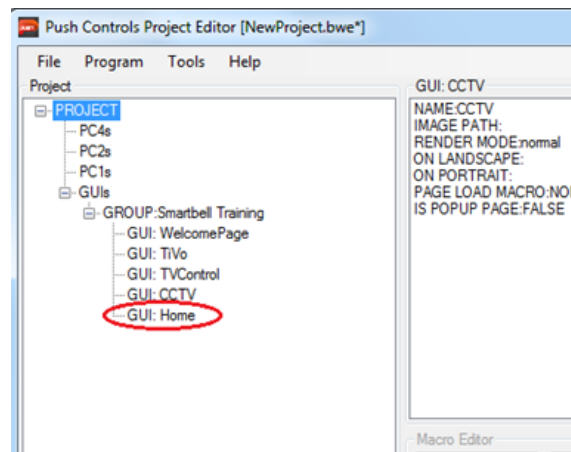

If you don't have the Push Controls app installed on your device and someone presses the **Smart Home** button, it will display the following message.



To return back to the Ness Smartbell app again from the Push App you can add a URL Scheme.

To do this add this URL Scheme, add a button to the GUI page by right clicking in the GUI page and click **Add > New Button** in the Push project editor, GUI page.

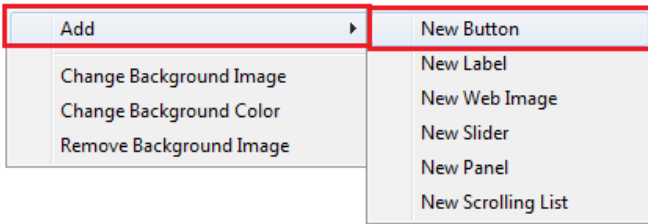

Now you need to change the Navigation drop down menu to **URL Scheme** and enter in the URL Scheme to be **nesssmartbell://** now when you press this button it will load up the Ness Smartbell app.

Note: The URL Scheme has three 's' in the URL Scheme. This URL scheme must also be in lowercase.

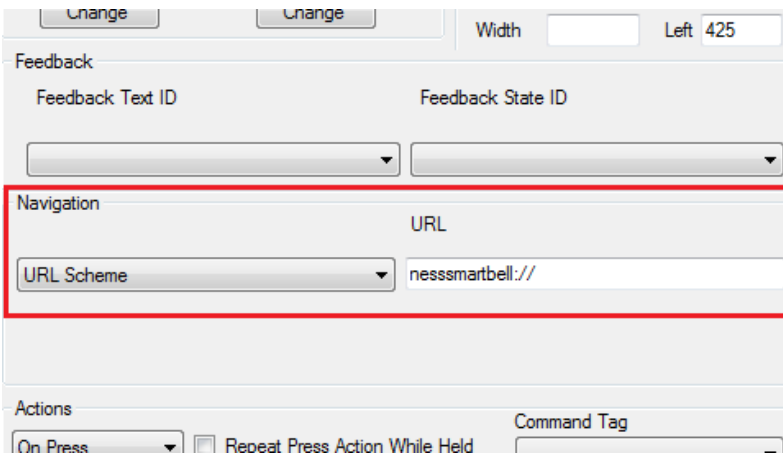

Monitoring the Camera on a Door Phone

Press the **Monitor** button from the home screen and tap on the Door station you which to monitor.

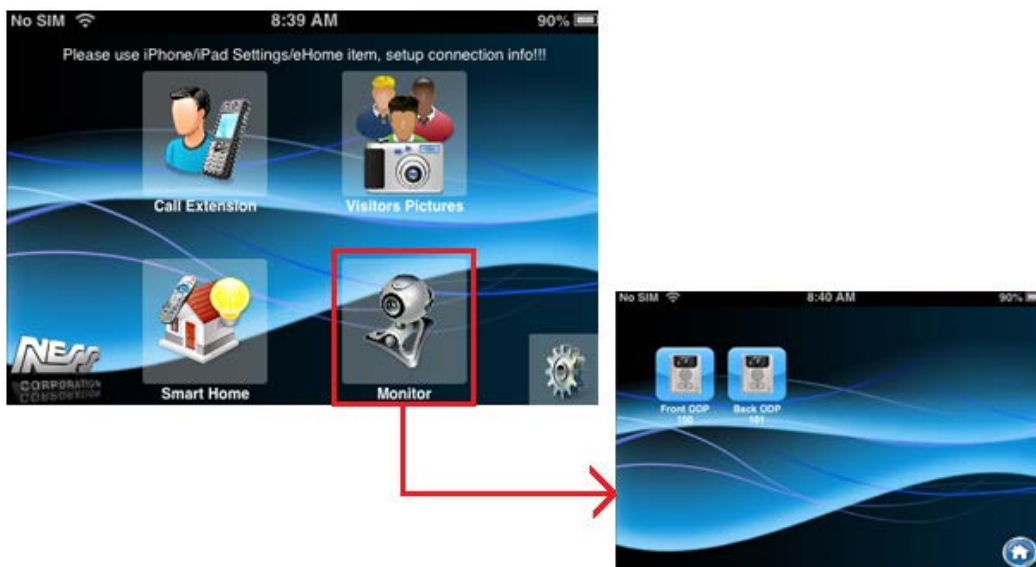

SETUP

- SETUP page for Smart phone allows you to setup the following 7 features;
 - Ringtone Settings,
 - Background Settings,
 - Modify Registration Message, *(used to pair / program the device into the eGateway)*
 - Card Settings, *(used to Add / Delete / disable Access Cards into a door station)*
 - Volume,
 - Version
 - Terminal Equipment.



SETUP Page for Mobile Device

- SETUP page for Indoor phone/Master station (10" tablet 101-132) allows you to setup the following 8 features;
 - Ringtone Settings,
 - Background Settings,
 - Modify Registration Message,
 - Card Settings,
 - Volume,
 - Version
 - Terminal Equipment,
 - Slide show.



SETUP Page for 10" tablet 101-132

RINGTONE Settings

You can store ringtone files in the SD card file “Ring” folder of your smart-Phone and then select it as your Ringtone when the intercom activates.

There are many ways to load the ringtone to your Android device.

1. If you have a USB cable you can plug your phone into the computer and find the ‘ring’ folder and copy the files into this folder.
2. Use and load an app called **AirDroid** which is a free app from the Google Play Store and you can transfer the ringtones to your phone wirelessly over the Wi-Fi using your computer.
(<https://play.google.com/store/apps/details?id=com.sand.airdroid>)

Once the app is installed on your Android device, you then need to make sure your computer is connected to the same Wi-Fi Network as your Android Device.

Once you have confirmed your connected to the same Wi-Fi network then open the AirDroid app.



It will now tell you what your IP address is in that app and you need to open a web browser such as Internet Explore and type in the URL it shows you in the app.

When you are asked, tap on the 'Accept' button on your Android Device.

Your Android device can now be accessed within the web browser and will allow you to do many things.

Since we are going to be copying a ringtone you need to click on the 'Files' icon in the web browser.



A window like below will then appear:

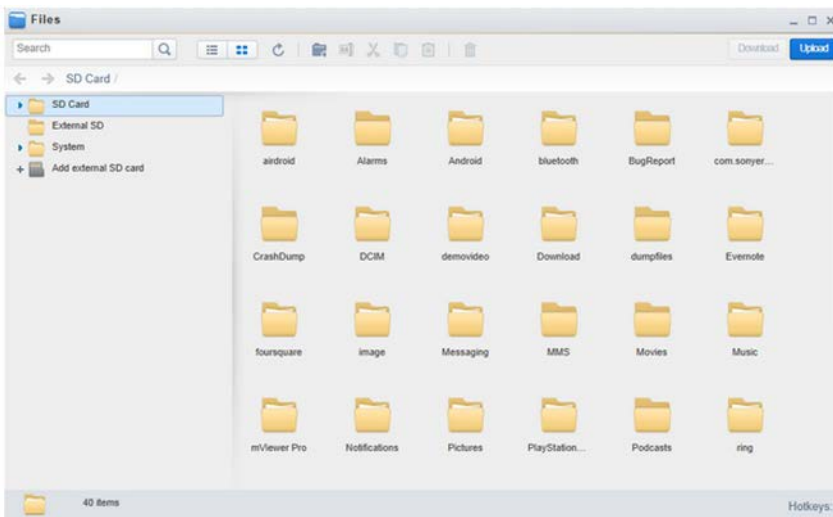

Now simply select **SD Card** from the left menu and scroll down into you get to **ring**.

Now you need to right mouse click in the empty space on the right and choose **Upload**

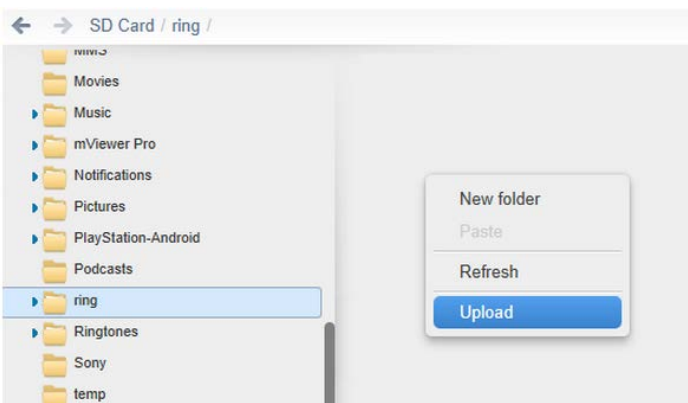

You now have two options.

1. You can click on the **Select Files** button up the top right and browse for the ringtone (mp3 file) on your computer
2. Drag and drop the mp3 file from your computer into this window.

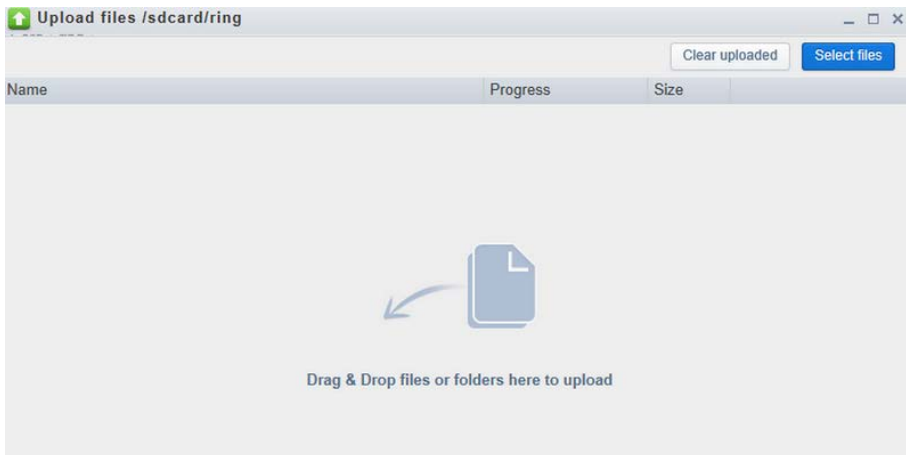

Once the file has been copied to this window, you can then close the web browser. Then on your Android device, you can press the back button and press the **OK** button to close the app. (by pressing the home button you will find the app is still running in the title bar, so you need to press the back button)

Now you need to open the Ness Smartbell app and click on the **settings** button down the bottom right of the screen.

Then select the **Ringtone Settings** button and then when you press the **Door Phone Ringtone** button the new ringtone will then display.

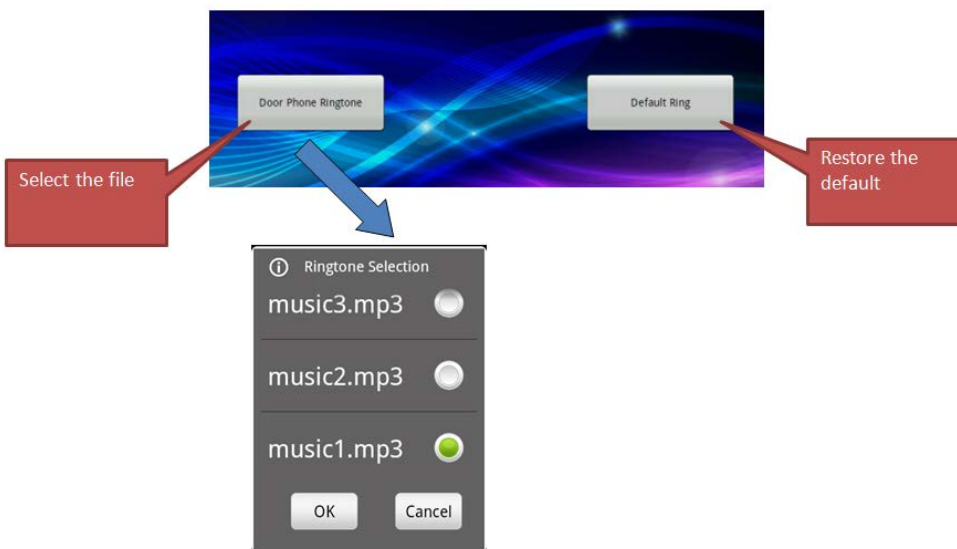

Background Settings

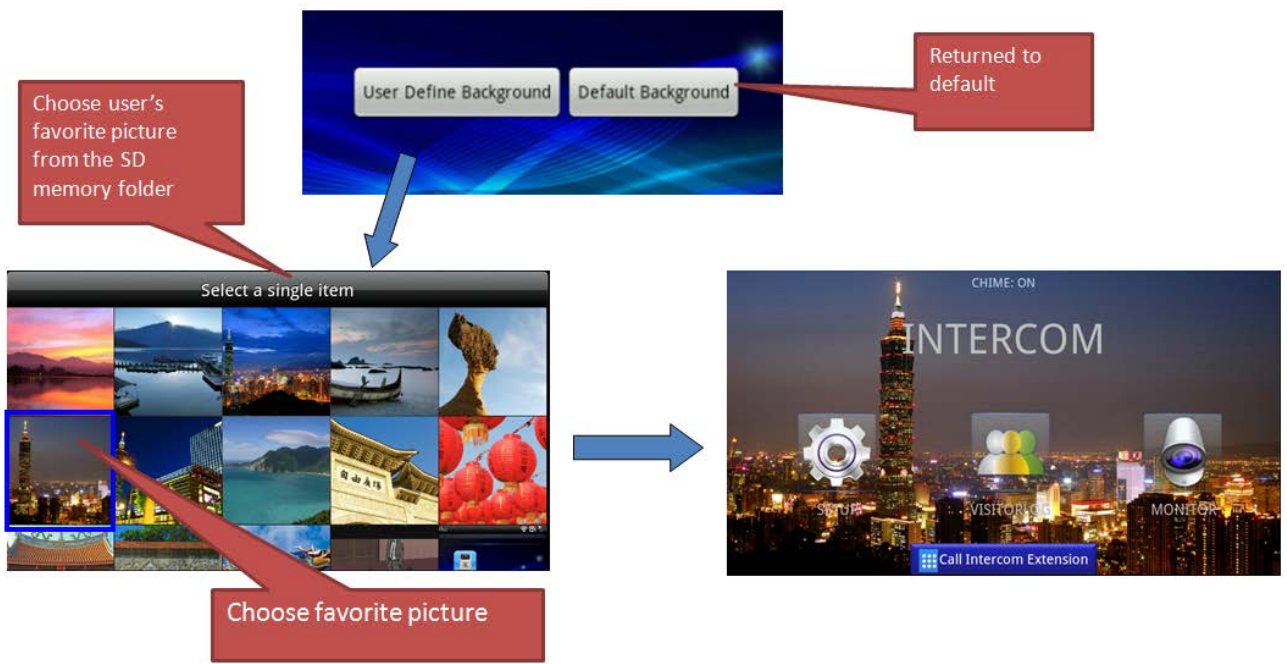

Modify Registration Message



Warning: to modify the registration information (Account, password and the server address) must be the same as the registration information recorded on the e-GW, otherwise it will result in registration failure.

Existing registration information: Extension / unit number as registered into the eGateway controller. (This must be unique for each device).

Existing registration information: Account / password

Server Address of the eGateway (eGateway's WAN IP address)

Your routers External IP Address

Press this button to start the registration procedure.

To create or modify a new registration information (Account, password and server address), this user will be registered to:

1. First enable pairing (registration mode) in the eGateway.
2. Registration on this device, otherwise it will result in a registration failure.

Modify Registration Message flow chart

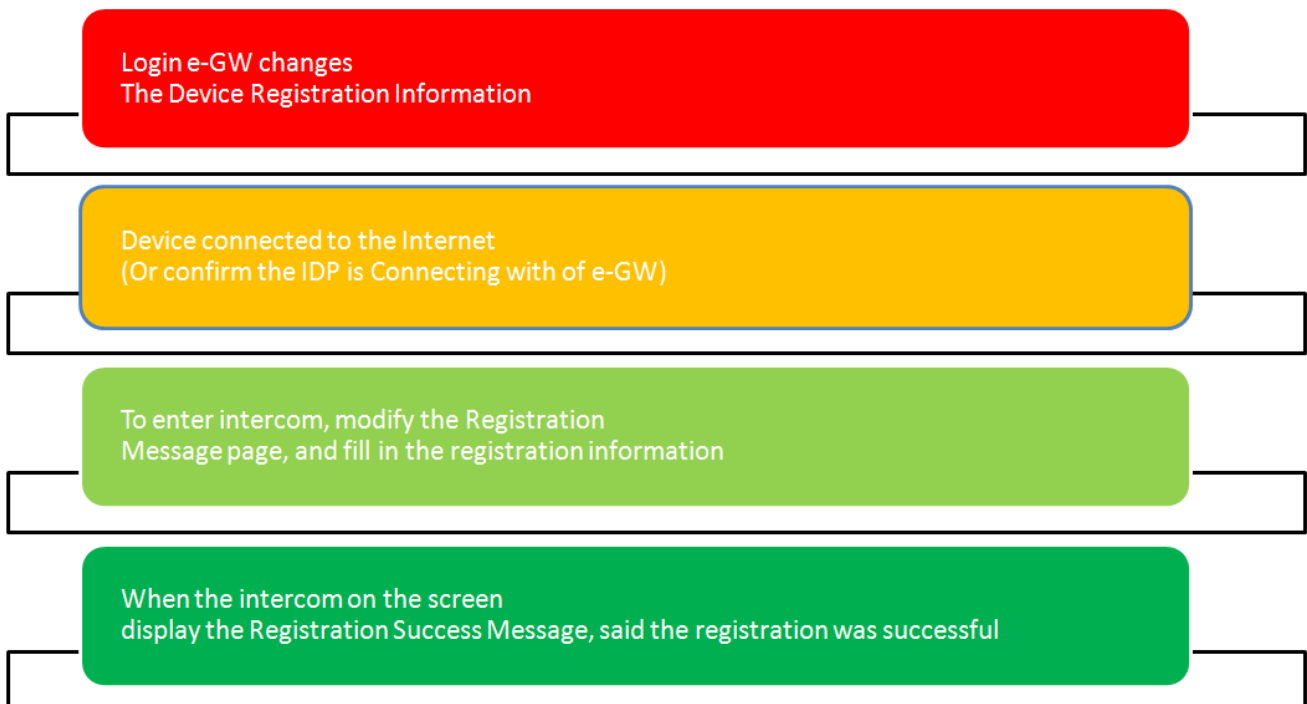

Access Card Settings

- You can easily add or set the access card(s) into the system that will allow them to unlock a door when presented to the Card Reader included in the Outdoor phone unit.
 - There is a Maximum of 32 cards that can be programmed and used on the system.
- From the main menu click on Setup / Card Settings
 - To add a new access card: Click the "Start Detection" button.
 - Then present an Access Card to the Outdoor phone unit.
 - To stop adding new card click the "End Detection" button.
To edit a card already in the system, press and hold card number.
 -

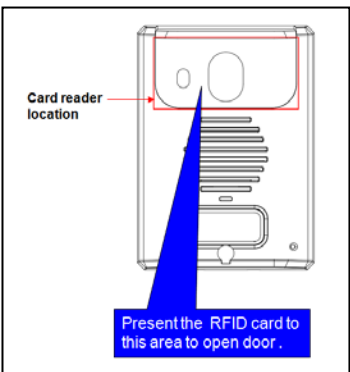

Card reader location

Present the RFID card to this area to open door.

- Add the access card:
 - Press the "Detect Cards, RFID card button to begin assay.
 - RFID card to brush off the lens of the ODP.
 - When displayed to the right card number detection success.
 - Press the "Cancel Detecting the end of the RFID card detection.

04e8b63a062480000000
General Card Available

Detect Cards
Cancel Detecting

"Long press" card number to enter the edit card information screen.

Edit name of card

Modify

ID: 04e8b63a062480000000
Name: Tomj

Card Type:
 General Card

Status:
 Available
 Lost

Set the card status is set to "Lost," this card is invalid.

OK Cancel

Back Homepage

Volume Settings

The Outdoor Phone (ODP) / Door station's volume can be adjusted using this setting.



ODP Volume

Audio Parameters

Adjustable front door and back door Speaker volume

Adjustable Device Microphone and Speaker Volume.

ODP Volume

Front Door medium

Back Door medium

OK Cancel

Microphone Volume

low

Speaker Volume

medium

OK

Version & Terminal equipment



The Version setup allows you to see the version details of the App you are running.



The Terminal equipment option allows you to view all other equipment that is currently registered / paired into the system that you can communicate with.

Slideshow settings (only for Indoor Phone 101-132 (10" tablet))

The 10" tablet (101-132) allows you to set a slide show to be displayed when it goes into "Screen Saver: mode.

User Photos need to be stored in the SD-Card album folder.

This is set by pressing the Slide show" button in the setup menu.



Notes on CAT5e Cable

- Do not bend the cables to an extent where the radius is less than 25 mm (1"). Communication failure could result.
- Do not remove the CAT5e cable jacket more than necessary.
- Arrange the color code of the RJ45 connections in accordance with EIA/TIA-568A or 568B.

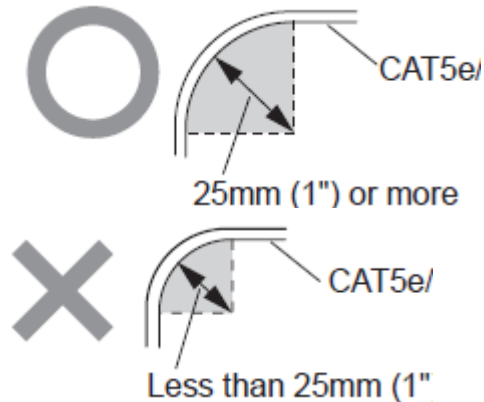

- Arrange the color code of the RJ45 connections in accordance with EIA/TIA-568A or 568B.

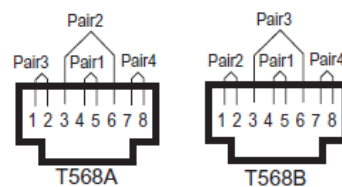

- Be sure to check the condition of cable connections with a LAN checker before connecting with a LAN cable.
- An RJ45 connector with a cover cannot be connected to the port for CAT5e on IP master stations or IP door stations. Use a cable without a cover.
- Do not pull or put excess strain on CAT5e cables.
- Use a straight-through cable for connecting units.



Warranty

- We warrants its products to be free from defects of material and workmanship under normal use and service for a period of one year after delivery and will repair free of charge or replace at no charge, should it become defective upon which examination shall disclose to be defective and under warranty.
- We reserve unto itself the sole right to make the final decision whether there is a defect in materials and/or workmanship; and whether or not the product is within the warranty. This warranty shall not apply to any product which has been subject to misuse, neglect, accident, power surge, or to use in violation of instructions furnished, nor extended to units which have been repaired or altered outside of the factory. This warranty does not cover batteries or damage caused by batteries used in connection with the unit.
- We will not be responsible for any costs incurred involving onsite service calls. We will not provide compensation for any loss or damage incurred by the breakdown or malfunction of its products during use, or for any consequent inconvenience or losses that may result.

Installation Steps – Network & Wifi setting

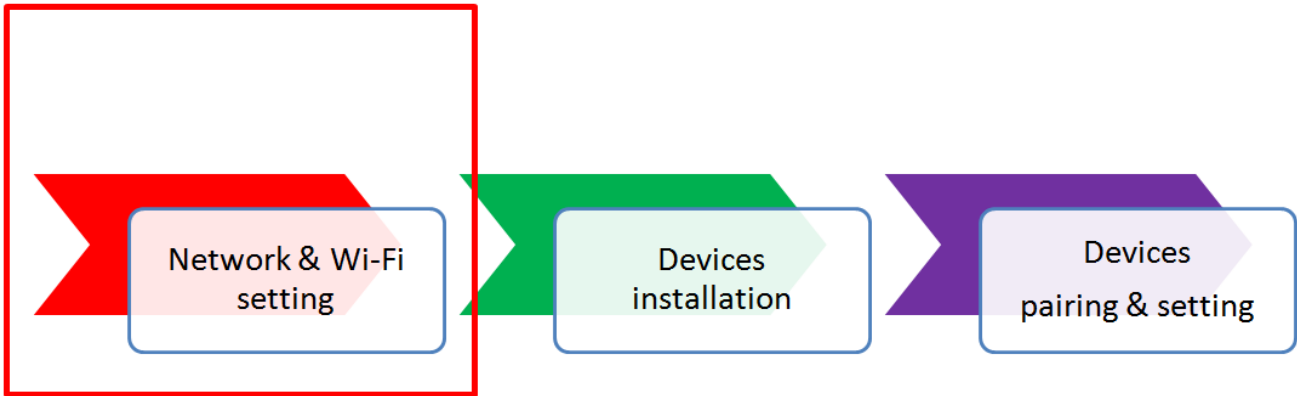

Network connection Architecture

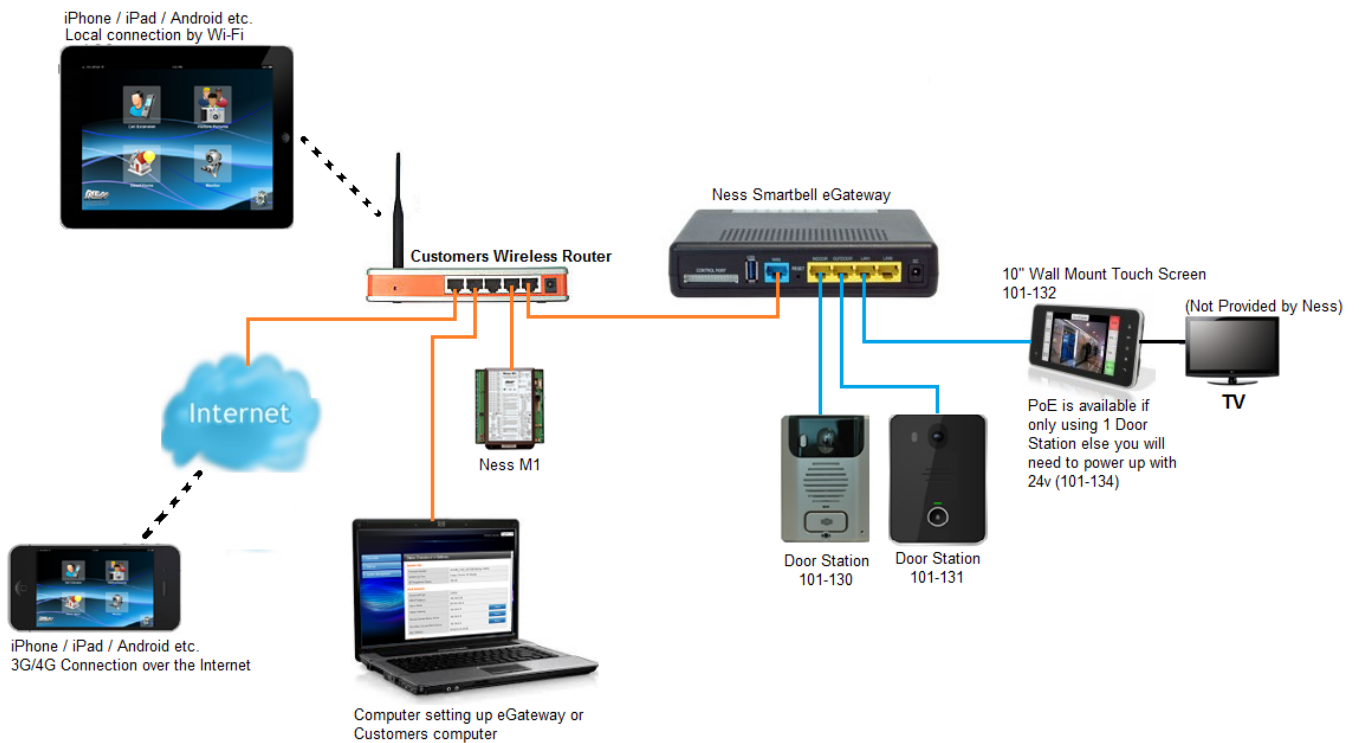

DO NOT connect Outdoor or Indoor phones or room stations to the customers LAN. All devices are wired in a closed network into the Ness IP e-Gateway. The eGateway is then connected to the LAN from the WAN port.

WiFi Router Setting

There are three main steps when setting up your WiFi router.

1. Enable DHCP Server and set a different IP segment with DHCP setting of e-Gateway.
2. Reserve a fixed IP address to e-Gateway.
3. Set IP address of e-Gateway to DMZ (Demilitarized Zone)

- 1. Enable DHCP Server and set a different IP segment with DHCP setting of e-Gateway.**
(Note: The default IP segment of e-Gateway is 192.168.0.10.)

The following screen shot is an example of the settings in a Wireless router. (You usually can find this setting from Network setting section in your wireless router.)

DHCP SERVER SETTINGS

Use this section to configure the built-in DHCP Server to assign IP addresses to the computers on your network.

Enable DHCP Server :

DHCP IP Address Range : 192.168.1.100 to 192.168.1.200

DHCP Lease Time : 10080 (minutes)

Always Broadcast : (compatibility for some DHCP Clients)

NetBIOS announcement :

Learn NetBIOS from WAN :

NetBIOS Scope : (optional)

NetBIOS node type : Broadcast only (use when no WINS servers configured)
 Point-to-Point (no broadcast)
 Mixed-mode (Broadcast then Point-to-Point)
 Hybrid (Point-to-Point then Broadcast)

Primary WINS IP Address : 0.0.0.0

Secondary WINS IP Address : 0.0.0.0

Enable DHCP Server

Set an IP segment

- 2. Reserve a fixed IP address to e-Gateway.**

ADD/EDIT DHCP RESERVATION

Enable :

Computer Name : e-Gateway << Computer Name

IP Address : 192.168.1.100

MAC Address : 00:19:15:d2:cf:e3

Copy Your PC's MAC Address

Save Clear

Reserve a fixed IP address To e-Gateway.

(You usually can find this setting from Network setting section in your wireless router.)

- 3. Set IP address of e-Gateway to DMZ**

DMZ HOST

The DMZ (Demilitarized Zone) option lets you set a single computer on your network outside of the router. If you have a computer that cannot run Internet applications successfully from behind the router, then you can place the computer into the DMZ for unrestricted Internet access.

Note: Putting a computer in the DMZ may expose that computer to a variety of security risks. Use of this option is only recommended as a last resort.

Enable DMZ :

DMZ IP Address : 192.168.1.100 << Computer Name

Reserve a fixed IP address To e-Gateway.

(You can often find this setting in the Firewall setting section of your router.)

Setting up the eGateway for the first time

1. Direct connect your computer to LAN1 on the eGateway.



2. By default the LAN IP address of the eGateway is set to 192.168.0.10. Open a web browser such as Internet Explorer and enter in 192.168.0.10 then press enter.

When prompt for a username and password enter in:

Username: admin

Password: admin



3. Once logged in, select **Settings > LAN** from the side menu.



4. Enter in an IP address in the first field.

Note: This IP address needs to be a different IP address then the customer's network.
For Example: If the customer's network has the IP of 192.168.0.xx then you would need to enter in something like 192.168.5.10 as this IP address.

The rest of the fields should automatically change based on the IP address you set.

Once this IP address has been set you need to click the **Apply** button at the bottom of the page.

Then close the browser after clicking apply.

LAN Setup

IP Address	192.168.5.10
Subnet Mask	255.255.255.0
MAC Address	00:19:15:DA:4C:0C
DHCP Type	Server
Start IP Address	192.168.5.11
End IP Address	192.168.5.254
Subnet Mask	255.255.255.0
Primary DNS Server	192.168.5.10
Secondary DNS Server	
Default Gateway	192.168.5.10

5. Once the IP address has been set, you will need to change your computers IP address so it's on the same network range as what you put in step 4 above and you will need to close the web browser.

For Example: If your IP address you set in step 4 is 192.168.5.10 then you would change your computers IP address as 192.168.5.xx (other than 192.168.5.10)

6. Re-open your web browser and enter in the IP address you set in step 4. (You should still have the LAN cable plugged into LAN1 that is connected to your computer)

7. Once logged in, select **Settings > WAN** from the side menu.

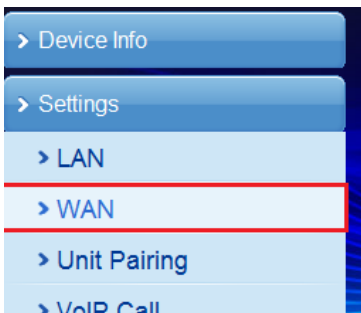

8. You now need to set the following:

WAN Connection type needs to be set to **STATIC**

IP address, needs to be a IP that matches to the same network range as the customer network.

Subnet mask needs to be the same as your customers network subnet mask

In most cases the **Default gateway** will be your routers IP address.

The Primary and Secondary DNS in most cases can be your routers IP address or if you know your ISP DNS server enter it into these fields.

Once those settings have been set, click on the **Apply** button.

Wide Area Network (WAN) Settings

WAN Connection Type:	STATIC (fixed IP) ▼
Static Mode	
IP Address	192.168.0.10
Subnet Mask	255.255.255.0
Default Gateway	192.168.0.1
Primary DNS Server	192.168.0.1
Secondary DNS Server	192.168.0.1

MAC Clone

Enabled	Disable ▼
---------	-----------

9. Remove the LAN cable from the **LAN1** port and plug it into the **WAN** port on the eGateway.



10. Change your computers IP address to match the same network range as what you entered the IP address from step 8.

11. Open Internet Explorer and enter in the IP address you set from step 8 and login using the username **admin** and the password **admin**.

Now the eGateway has been setup and ready for new devices to be paired and setup.

From now on, you only connect using the **WAN** port (blue port) and the IP address you set in step 8.

Installation steps – Device Installation

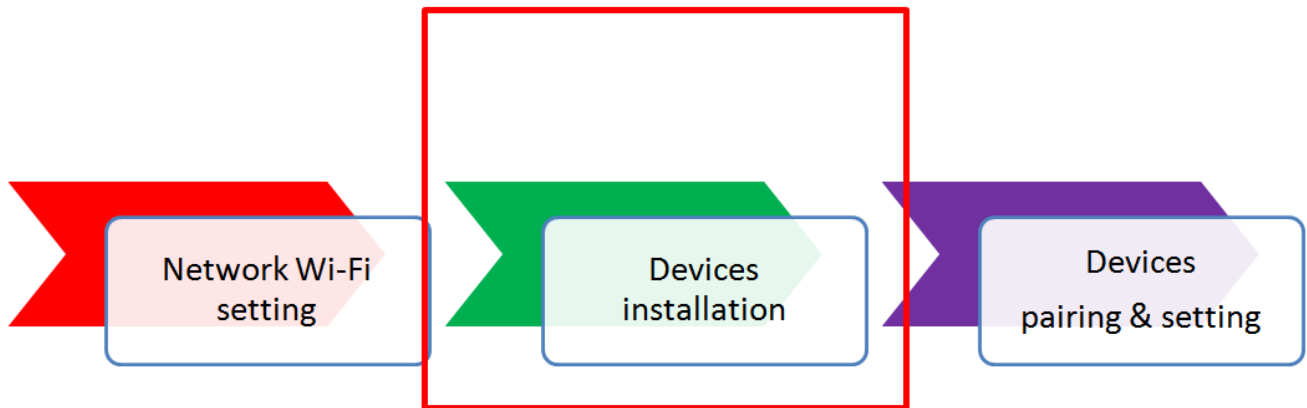

Installing the Outdoor Phone (ODP)



Surface Mount



Flush Mount



NOTE: Each Outdoor Phone / Door station must be wired direct back to the eGateway Outdoor Port using suitable Cat5e / Cat6 Data cable.

Do not connect these units to your customers LAN data network.



Note: The Indoor & Outdoor ports on the eGateway module are POE (Power over Ethernet). Therefore Indoor / Master Room stations and Outdoor Phones / Door Stations connected to these ports, are powered off these ports, therefore no need to additional power supplies.

“However If more than 2 devices are needed to be installed you can use LAN1 and LAN 2 ports on the eGateway, however external power supplies will be required to power these additional modules connected to LAN 1 & LAN 2 ports

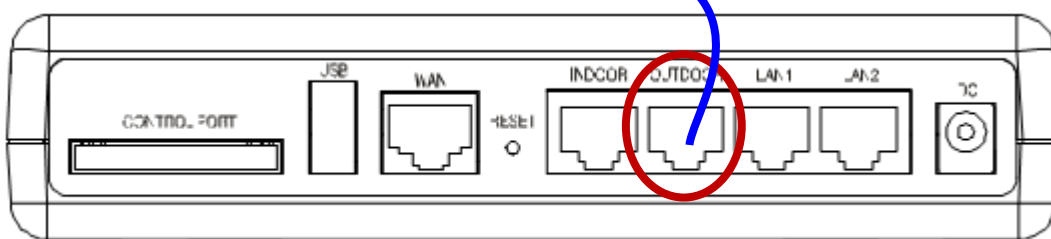

● Accessory

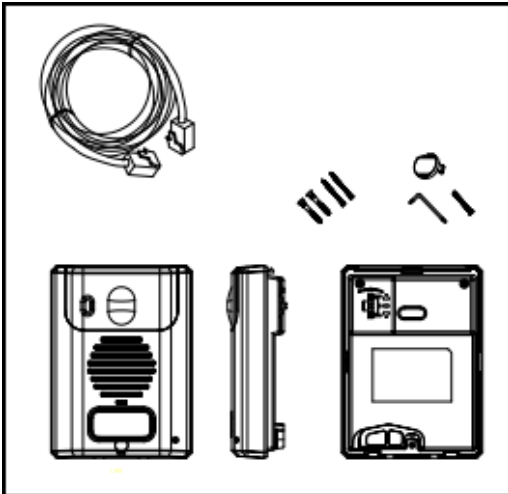

Accessories included

- 1 x Cinufoil Screw Driver
- 2 x Special Wooden Screw RH
- 1 x Special Screw M3 1.4mm Fe Ni PAN HEAP Torx
- 1 x Wall Mount box
- 1 x Screw cover
- 2 x Screw Plug (Utility) for Z-In3 12

Back panel (wall mount model)



Front panel

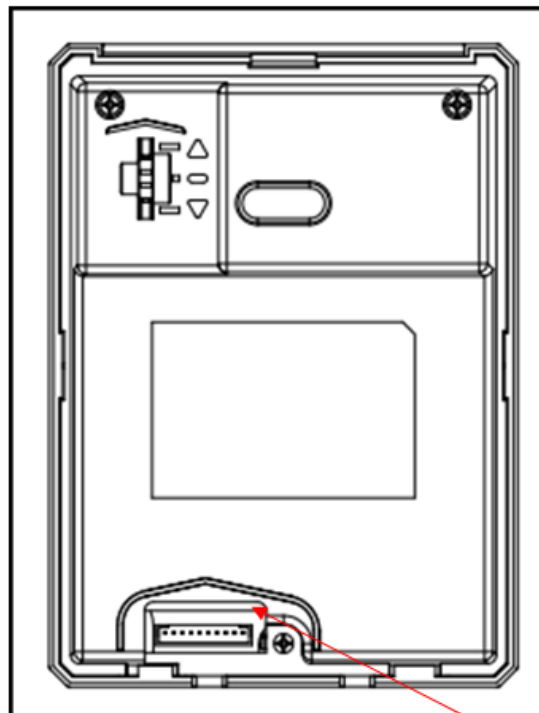









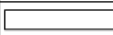



Back panel

Please record MAC address before proceed the device pairing.

Cable set with RJ45 connector & wire set

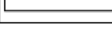
Outdoor Phone wire connection table.

PIN	Function	Description	Pin color
1	R+	Network RX+	 white
2	R-	Network RX-	 orange
3	T+	Network TX+	 white
4	T-	Network TX-	 green
5	SP1	eGayway Power DC 12 to 24V	 white
6	SP1	eGayway Power DC 12 to 24V	 blue
7	SP2	eGayway Power GND	 white
8	SP2	eGayway Power GND	 brown
9	12V	Adaptor +12V	 red
10	GND	Adaptor GND	 black
11	NC	Relay: normal close(dry contact)	 purple
12	NO	Relay: normal open(dry contact)	 yellow
13	COM	Relay: common terminal(dry contact)	 gray
14	DI	Sensor input	 white

Connectivity assignment – color of wire and identification

Mounting & surface wiring

1. Mount the back box onto / into the wall and secure

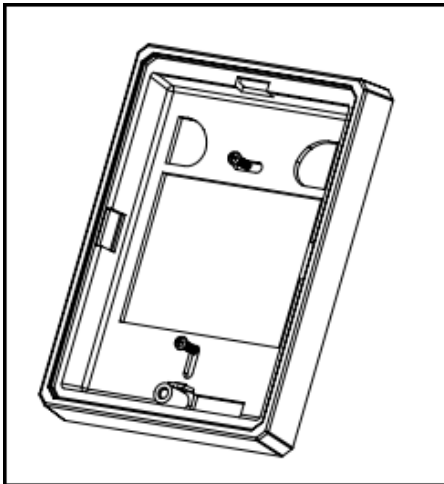

2. Pull the wire from the Wall,

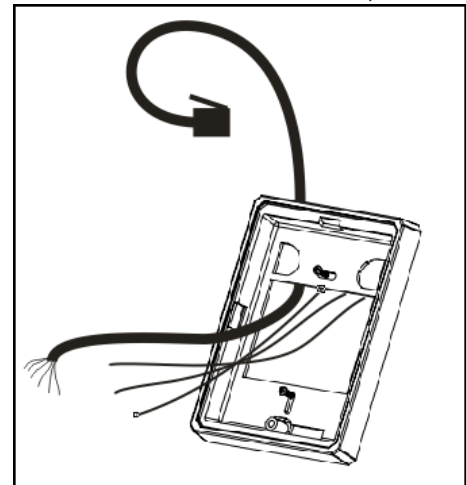

3. Wire connected with door phone unit

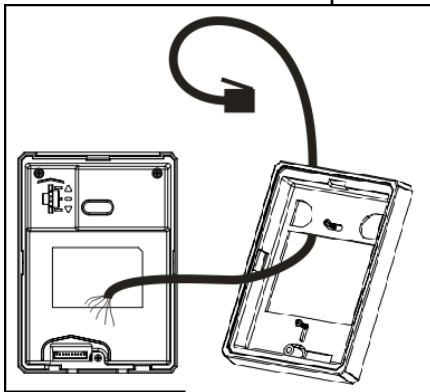

4. Connect cables to the Outdoor Phone unit.

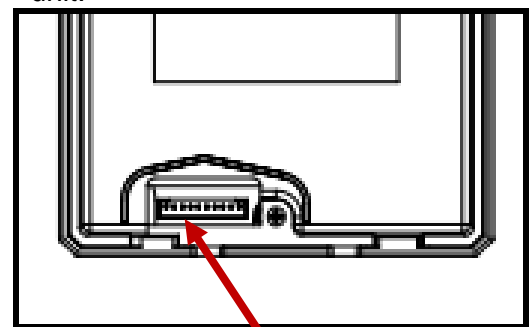

Cable set with RJ45 connector & wire set

Connections to electronic door strike/lock

- The connectivity point defined on door phone for electronic door strike/lock is in accordance with – PT, AC, EL.

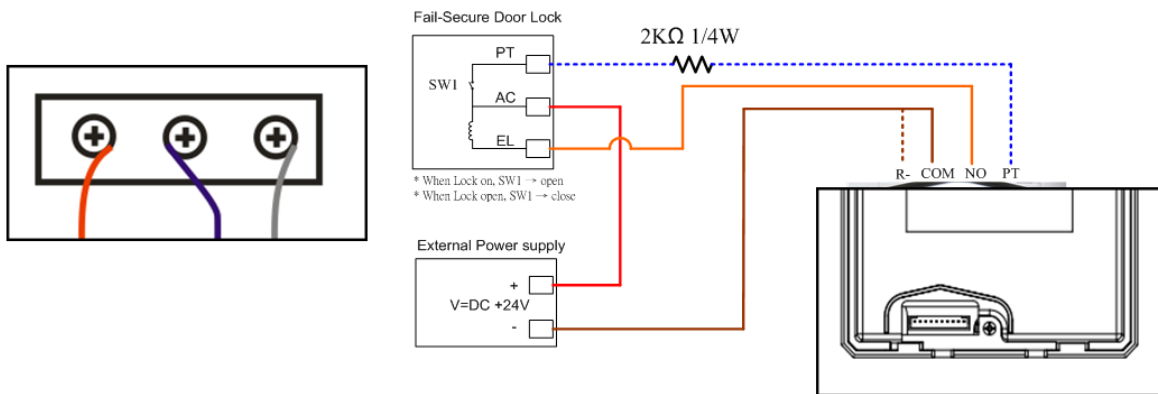

NOTES

- Connect to the electric door strike according to its specifications.
- Do not use the unoccupied terminals and ports for other purposes.
- In order to prevent incorrect wiring, label both ends of each cable with the unit and terminal names to which they are to be connected.
- For connecting other manufacturer's products, refer to the instruction manuals for those products.
- The illustration of the unit's rear panel differs from the actual one. This is for simplifying the connection diagram.

Door Strike Wiring Examples

Power To Lock

Door strike is locked without any power

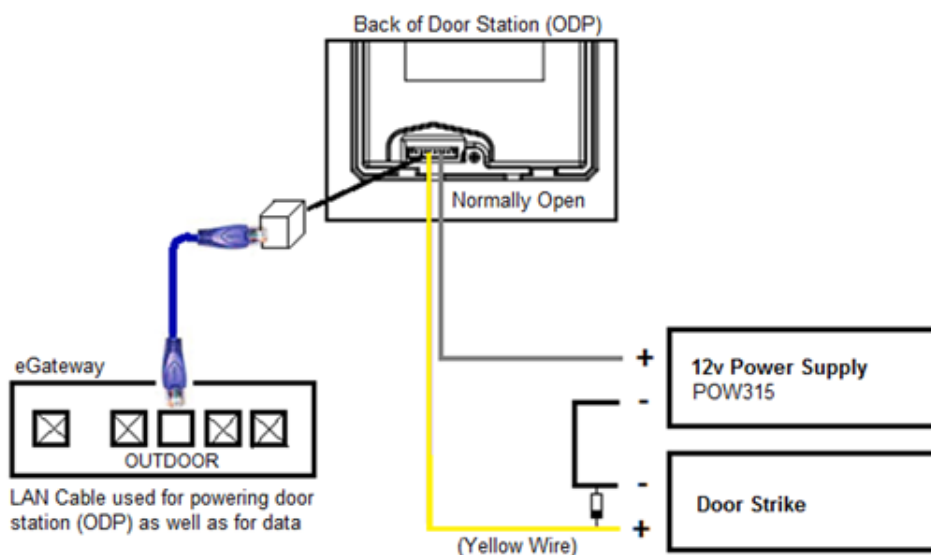

Power To Unlock

Door strike is unlocked and requires power to lock

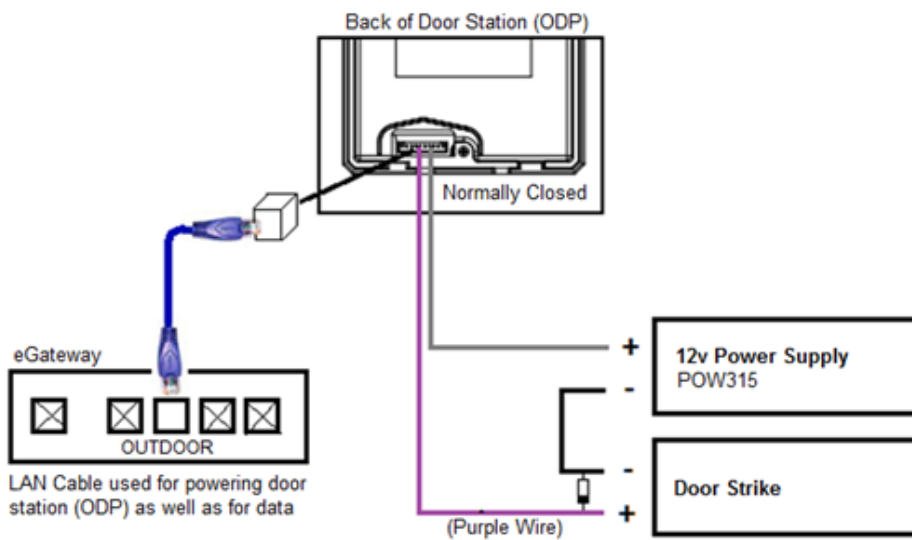

Complete the installation

- The outdoor unit will be pressed into the wall mount and use the fixed star screws and wrench
- Cleaning: Clean the units with a soft cloth dampened with a neutral household cleanser.
Do not use an abrasive cleanser or cloth.

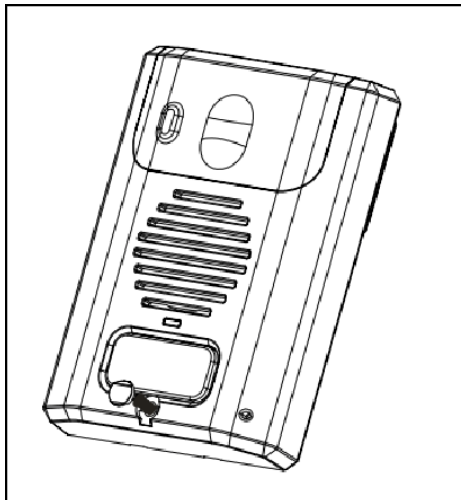

Mounting locations



Do not install this unit in any of the following locations where lighting or the ambient environment could impact the display on the Video monitor due to the characteristics of the door station's camera.

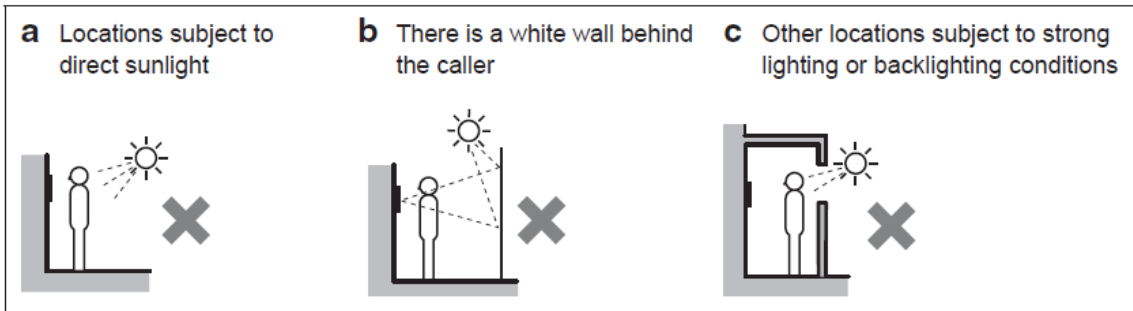

Mounting positions and image view

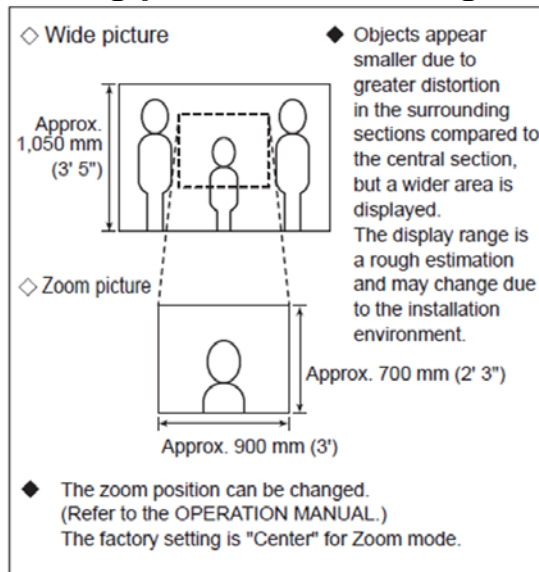

◇ Wide picture

Up/Down



Left/Right

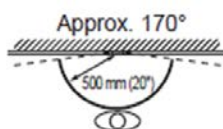

◆ An area over a range of approx. 170° in a 500 mm (20") radius from the camera displays. (The display range is a rough estimation and may change due to the installation environment.)

Indoor Phone / Master Station, 10” tablet (101-132B) installation



NOTE: Each Indoor Phone / Room station must be wired direct back to the eGateway Indoor Port using suitable Cat5e / Cat6 Data cable. Do not connect these units to your customers LAN data network.



Note: The Indoor & Outdoor ports on the eGateway module are POE (Power over Ethernet). Therefore Indoor / Master Room stations and Outdoor Phones / Door Stations connected to these ports, are powered off these ports, therefore no need to additional power supplies.
“However If more than 2 devices are needed to be installed you can use LAN1 and LAN 2 ports on the eGateway, however external power supplies will be required to power these additional modules connected to LAN 1 & LAN 2 ports

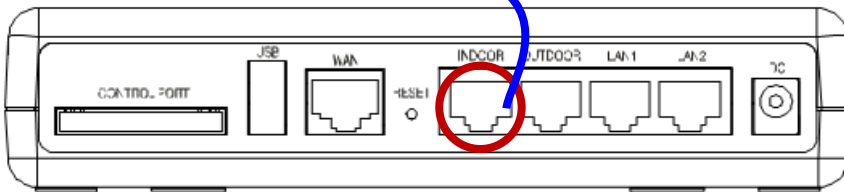

Powering the 10 inch indoor phone externally

NOTE:

When powering the 10” indoor phone with the Ness PoE LAN Switch (101-363) it requires 12/24VDC to power it.

Therefore DO NOT use the 48V power supply that comes with the switch. Instead please use a 24Volt power supply (101-134) (Sold separately) with the PoE LAN switch (101-363).

Powering up the 10 inch touch screen with the wrong voltage will void your warranty.



- Introduction of the unit



Installing the Wall Mount bracket

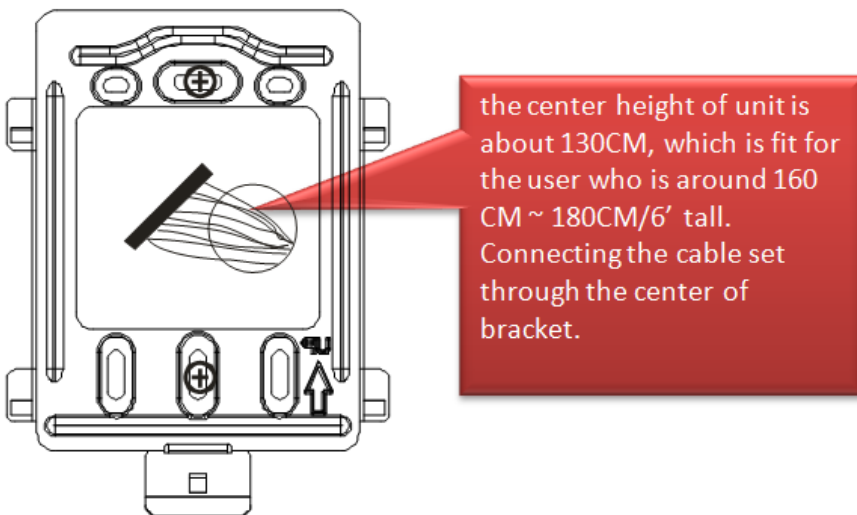

Mount the wall mount bracket to the wall and once secure place the Indoor Phone / Room Station, 10" Tablet onto the bracket as shown below.

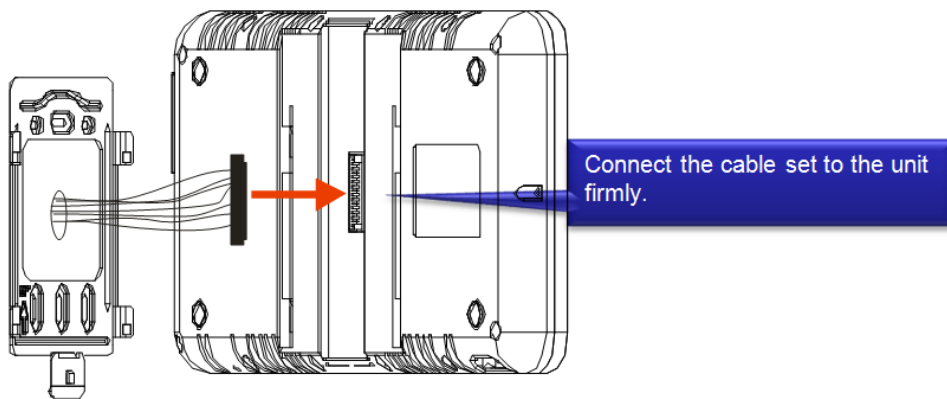

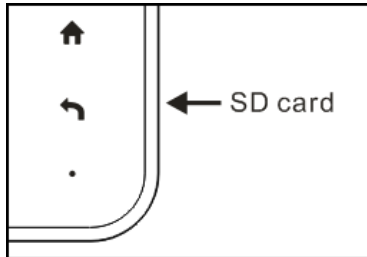
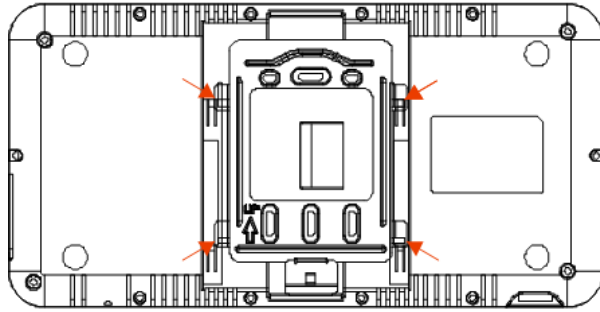

Insert SD Card (Not supplied as standard)

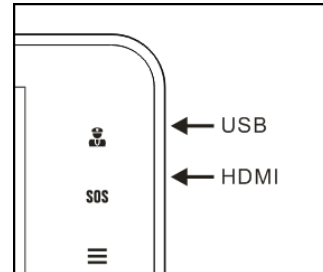

USB port can be connected with USB keyboard or mouse.
HDMI port can be connected to TV

Installation steps – Device Pairing

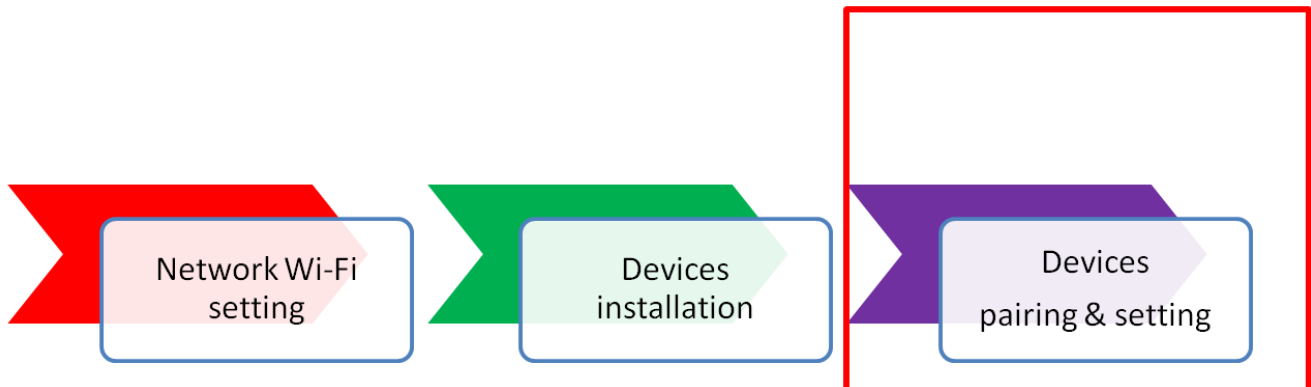

Starting up the settings & pairing

- Precaution:
 - You must complete the pairing of devices (ODP, the IDP, the IP Phone and Smart Phone) to the IP Intercom eGateway. Once they have been paired / programmed into the eGateway then they can be used in accordance with the intercom functionality as defined.
- Setting list:
 - ODP/10" IDP
 - IP Phone
 - Mobile tablet
 - Smart Phone
 - iPhone
- NOTES:
 - The following list is a brief overview of the setting items available in the system settings. The descriptions, and the style and order of descriptions do not necessarily equate with the actual displays.
 - Make a note of the setting results you have made by using the setting Information memo in case of unexpected data erasure, and keep it in a safe place not to lose it.

ODP/IDP pairing and setting flow

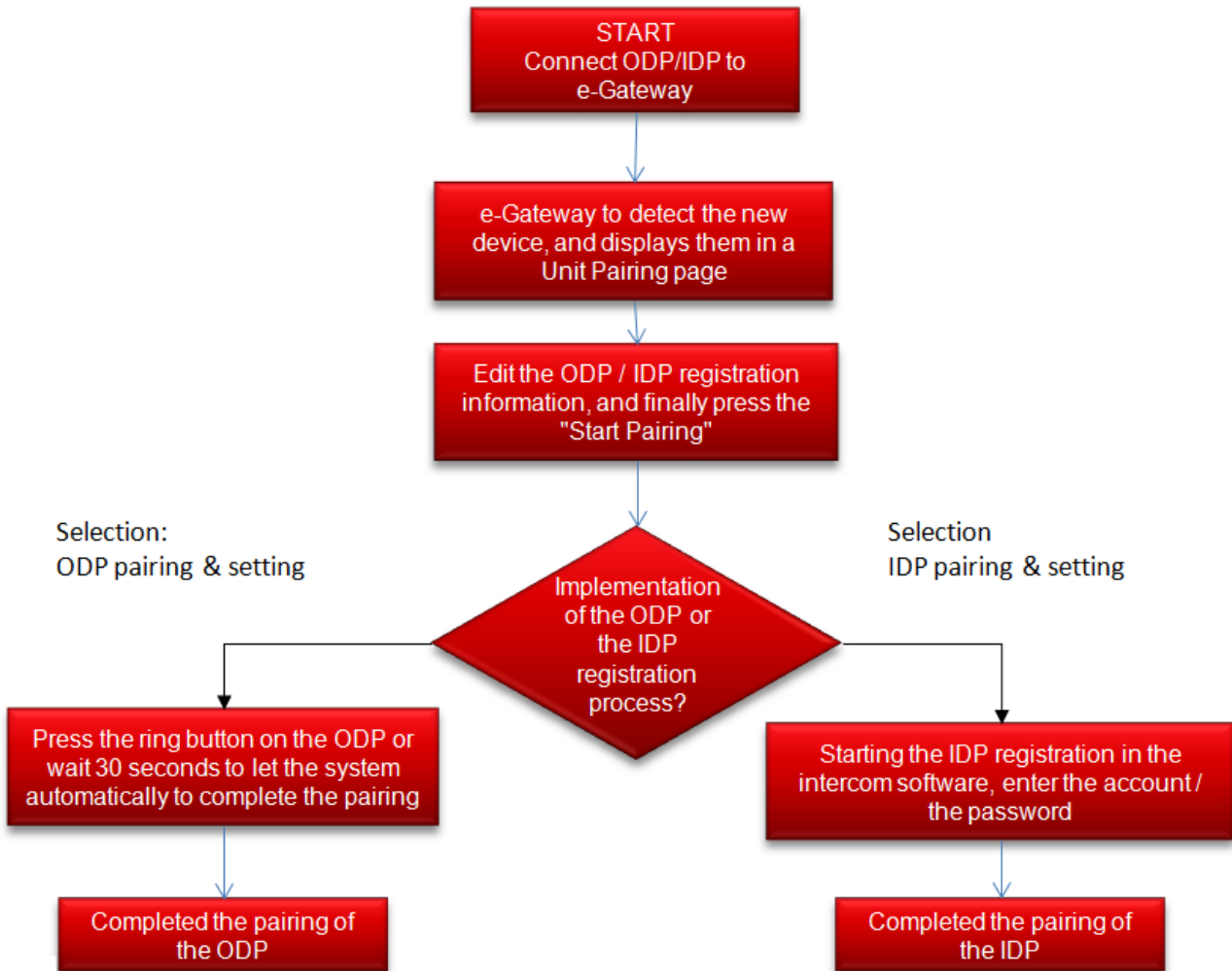

Devices connection to eGateway

- Connect the CAT5e cable of ODP to OUTDOOR port of e-GW

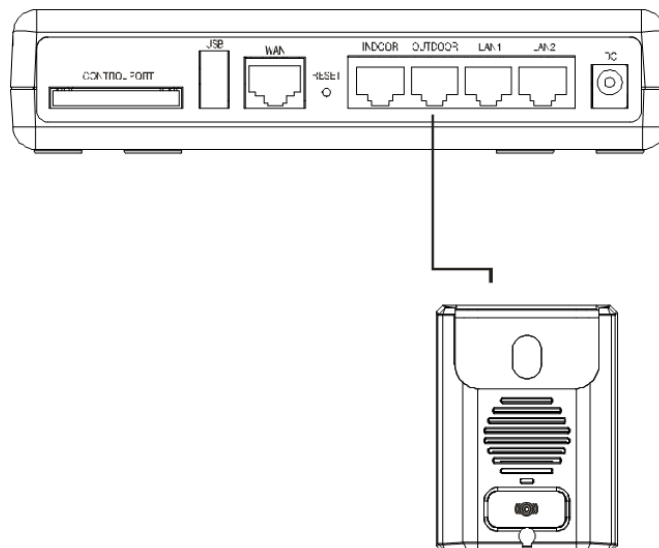

Connect the CAT5e cable of 101-132 10” tablet to INDOOR port of eGateway

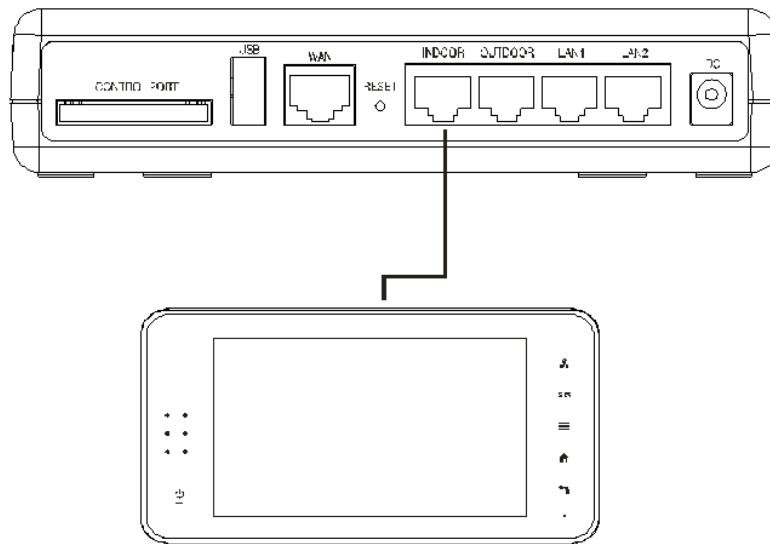

Connect ADSL Wire to eGateway WAN Port

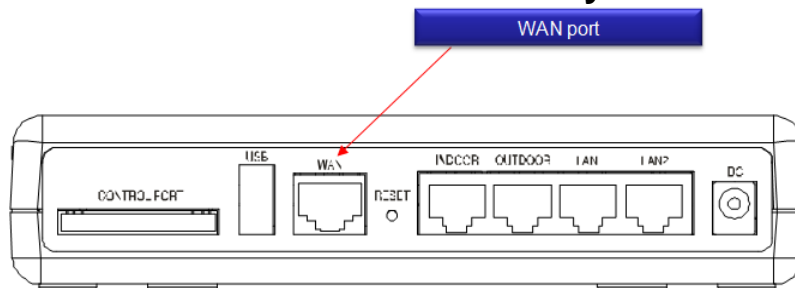

Connect Power to the eGateway

Note: Ensure you only use the power supply supplied with the eGateway.

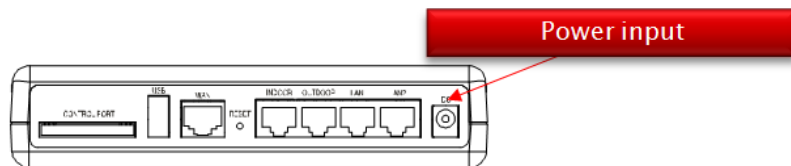

Ness SmartBell eGateway Specifications

Processor :	<ul style="list-style-type: none"> Ralink RT3052 @ 384MHz ; 64MB SDRAM, 16MB Flash
FE	<ul style="list-style-type: none"> 1 x FE/fast Ethernet for WAN 4 x FE/fast Ethernet for LAN
USB Host 2.0	<ul style="list-style-type: none"> For Future use
Digital Input	<ul style="list-style-type: none"> 8 x DI - (For Future use)
Digital Output	<ul style="list-style-type: none"> 4 x DO
RS-485	<ul style="list-style-type: none"> 1 X RS-485 - (For Future use)
Dimension	<ul style="list-style-type: none"> 170 mm * 115 mm * 37mm (L x W x H)
Support protocol	<ul style="list-style-type: none"> SIP 2.0 (RFC 3261)/TCP/IP/UDP, RTP, HTTP, ARP, ICMP, DHCP, DNS, TFTP, NTP



Outdoor phone pairing and setting flow

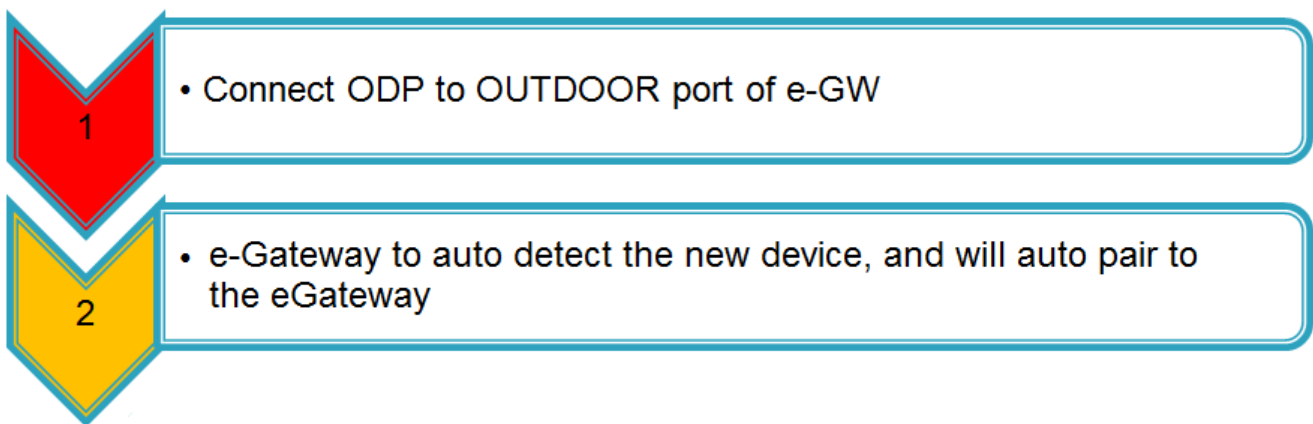

Outdoor Phone (ODP) / Door Unit - Device pairing to eGateway

1. Connect the ODP to the **Outdoor** port of the eGateway
2. The eGateway will identify the ODP unit and will automatically pair it.



ODP pairing completed

Once completed the Unit Pairing status will show **Connected**.

Unit Pairing Information

Unit Pairing Information

Name	Type	Account	Password	MAC Address	Status	Select
ODP	Outdoor Unit	100	gQJsvT	00:19:15:d2:cf:e2	Connected	<input type="checkbox"/>
7" IDP	Indoor Phone	102	102	48:5d:60:14:43:db	Disconnected	<input type="checkbox"/>
10"	Indoor Phone	101	101	00:19:15:d2:d0:0b	Disconnected	<input type="checkbox"/>

Refresh Delete Add Edit

Name your Outdoor station

Once the unit is paired click on the tick box next to your ODP and click **Edit**

Unit Pairing Information

Unit Pairing Information

Name	Type	Account	IP Address	MAC Address	Status	Select
	Outdoor Unit	100	192.168.5.44	00:19:15:da:2d:e1	Connected	<input checked="" type="checkbox"/>
	Outdoor Unit	101	192.168.5.159	00:19:15:da:2d:60	Connected	<input type="checkbox"/>

Refresh Delete Add Edit

Enter a name for your ODP (such as Front Door) and press the **Save** button.

Note: Do not change other settings on this page.

Edit Unit

Unit Information

Name	Front Door
Type	Outdoor Unit
Subtype	Front Door
Account	100
Password	xPTeRQ
MAC Address	00:19:15:da:2d:e1
IP Address	192.168.5.44
Status	Connected

Save Start Pairing Stop Pairing

Room Station / 10” tablet / Indoor Phone (101-132) pairing and setting flow

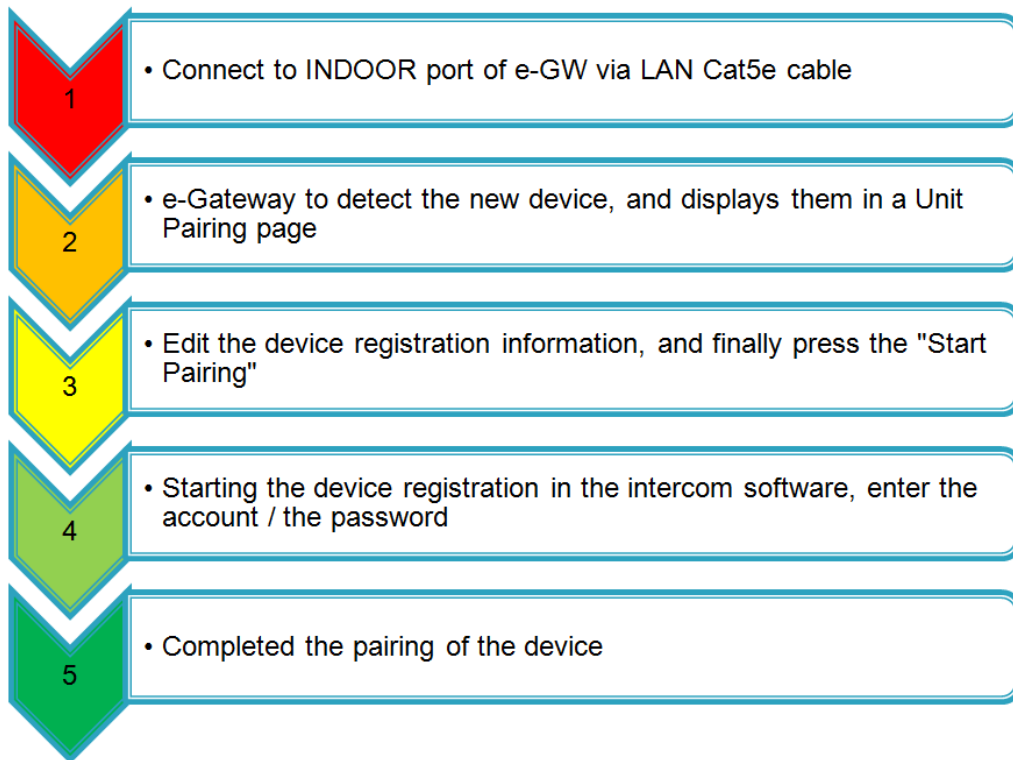

Device pairing of Room Station / 10" Indoor Phone to the eGateway

1. Click **Settings > Unit pairing**.
2. If there is already an Indoor phone in the table that is not part of your system, delete it so a new one can be added.



3. Connect the LAN Cable to the Indoor phone unit and the other end into the **Indoor** port.



4. Wait for about 30~40 seconds until the door phone is **automatically detected** and displayed in the “Unit Pairing information table”.

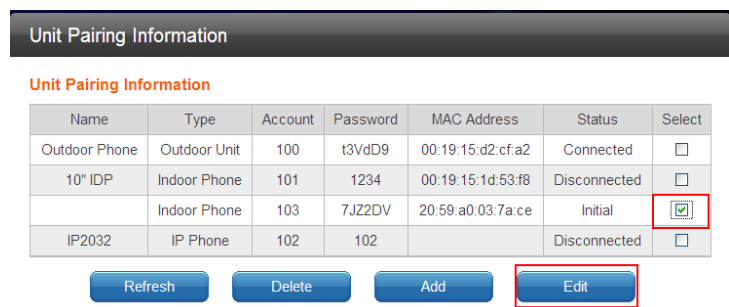

5. **SELECT** the new device and click **Edit**.

Edit Unit

Name Enter the appropriate name according to personal needs. (e.g. Kitchen)

Type Select **INDOOR PHONE**

Account Please fill in the range of 100 to 109 ensuring this number is not registered

Password Can be re-configured according to individual needs, or left as assigned by the eGateway.



Press the **Save** button
Then click **Start Pairing**

6. Open the App on the Master Room Station / 10" Indoor Phone, as per below:

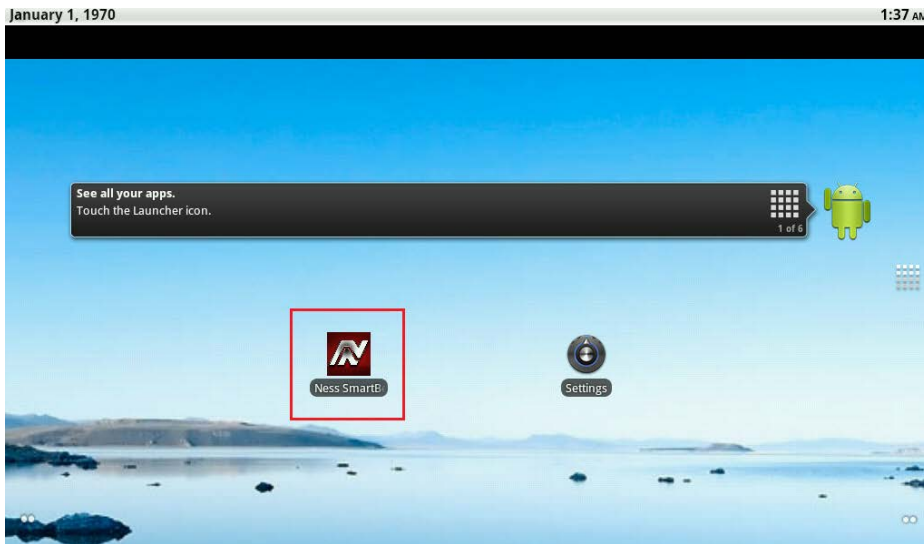

7. On the Master Room Station / 10" Indoor Phone enter in the following settings:

Extension No

Enter extension No (100-109) as per the pairing screen in the eGateway.

Password

Enter password as per the pairing screen in the eGateway.

Default Server Address & Server Address

Please enter the **LAN IP Address of the eGateway**

If you are not sure what the LAN IP is, then in the Web GUI of the eGateway, click on **Settings > LAN** and record the LAN IP (e.g. 192.168.5.10) **Do not use the WAN IP address** as you would with Smartphone devices.

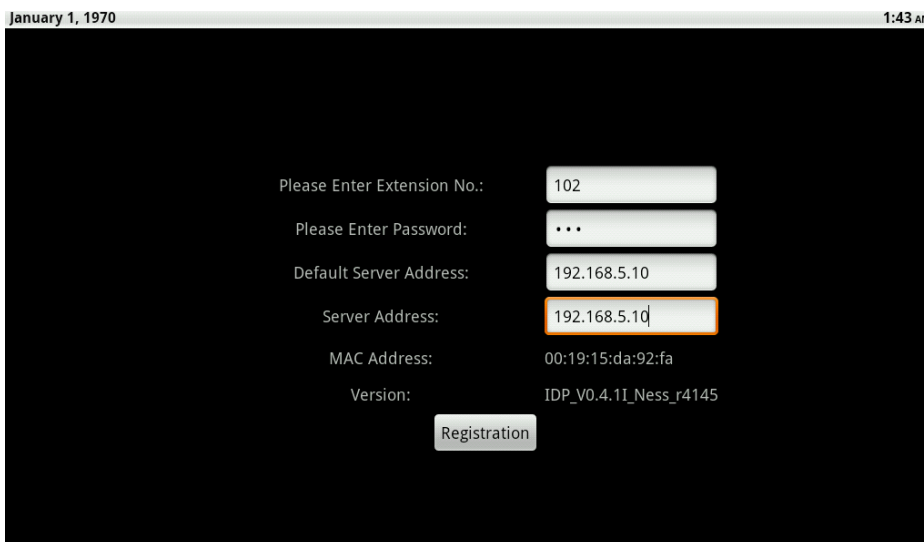

Once all details are entered, click on the **Registration** button.

To complete the 'Pairing' process, click on the **Save** button in the eGateway's web GUI to finish pairing.

Once successfully registered click "Homepage" on the Tablet and 'Unit Pairing' tab on the web GUI of the eGateway which should now show 'connected'.

Main IP intercom application (App)

Once Registration / Pairing is complete on the 10" Touch screen, the main page will be displayed.



Android Smart phone pairing and setting flow

Download The Smartbell app “User Software” from the Google Play store.
Search for “Ness Smartbell”



Ness Smartbell



Turn on Wi-Fi connection in the Smart Phone
Connect to eGateway via the Wi-Fi AP



Edit the device registration information in eGateway and then press “Start Pairing”



Start the device App on the Smartphone and complete the registration details, including
Account / Password eGateway IP address etc (to match those of the eGateway) and then press
‘Registration’



Completed the paring of the device.

Initiate Wi-Fi setting

Before you connect your Smartphone to the Intercom you need to ensure your phone is on the same Wi-Fi network.

Note: On some Android devices these Wi-Fi settings may look and have different labels, icons and names. Please use the following as a guide.

1. Open the **settings** app.

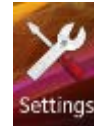

2. Click on **Wi-Fi**
(On some devices it may say 'Wireless and Networks')

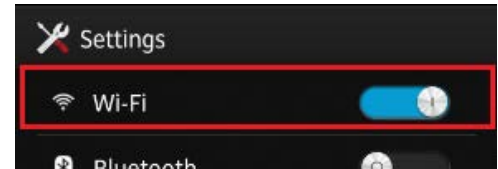

3. Ensure you are connected to the same network as your Ness Smartbell IP Intercom.

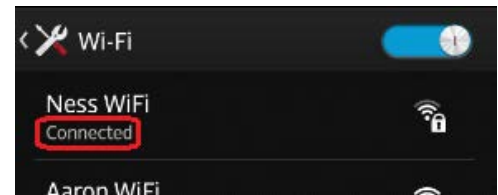

Android Smart Device pairing to the eGateway

1. Plug your computer into the same network as the **WAN Port** and connect using a web browser with the eGateway WAN IP address.



2. Enter in the username and password.
(Default User = admin Pass=admin)

3. Click **Settings > Unit pairing**.



4. Click the **Add** button.



5. SELECT the new device and click

Edit.

Unit Pairing Information

Name	Type	Account	IP Address	MAC Address	Status	Select
Back Door	Outdoor Unit	100	192.168.5.159	00:19:15:da:2d:60	Connected	<input type="checkbox"/>
	Smart Phone	XXX			Initial	<input checked="" type="checkbox"/>
IDP	Indoor Phone	102	192.168.5.61	00:19:15:da:92:fa	Disconnected	<input type="checkbox"/>

Refresh Delete Add **Edit**

Edit Unit

Name Enter the appropriate name according to personal needs. (e.g. Fred's Phone)

Type Select **Smart Phone**

Account Please fill in the range of 100 to 109 ensuring this number is not registered

Password Enter in a password.

Unit Information

Name	Android
Type	Smart Phone
Account	101
Password	101
MAC Address	
IP Address	
Status	Initial

Save

Press the **Save** button
Then click **Start Pairing**

6. When the Smart phone has **not been paired** with eGateway the following registration screen will appear.

7. Fill out the following items

Extension No

Enter Account (100-109) as per the pairing screen in the eGateway.

Password

Enter password as per the pairing screen in the eGateway.

Default Server Address

Please enter the eGateway's **WAN IP** Address.

Server Address

Enter in your routers external IP address. You can get this by typing in 'What is my IP' into Google.

8. Once the items have been filled in press the **Registration** button.

9. Once the pairing is complete, press the **save** button in the web GUI.

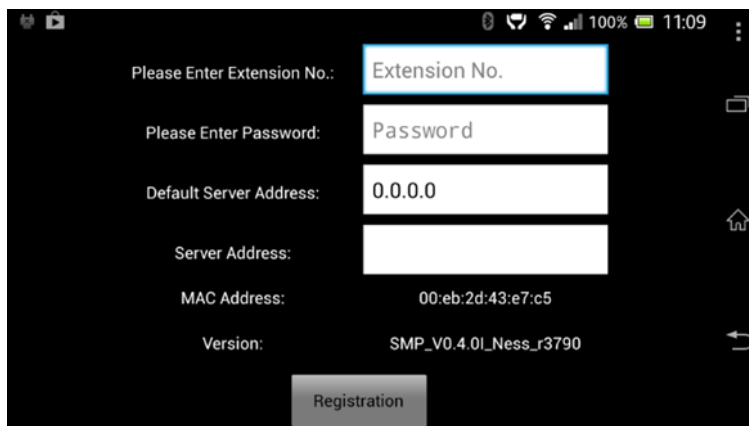

10. Once the Registration is complete, the main page will be displayed.

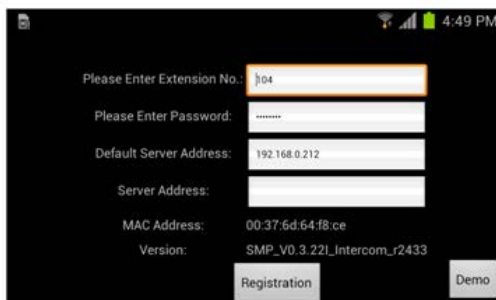

Important Note Re WMM and Audio on some Smart phones

Please Note: Some Android Smartphone's require **WMM (WiFi Multimedia)** to be enabled in the Wireless AP or Wireless routers for them to provide 2 way Audio back to the eGateway.

WMM maintains the priority of audio, video and voice applications in a Wi-Fi network so that other applications and traffic are less likely to slow them. In this way, in a phone conversation, you are less likely to hear delays. Watching video, you are more likely to see smooth action. This delays other network traffic of a less critical nature — such as downloading large files — where a small delay is acceptable.

In the Ness Smartbell a typical symptom of when this needs to be enabled is where on an android phone you can hear the person on your Smartphone; however they cannot hear you when you talk either at the Outdoor Phone (ODP) or on other Smartphones. If you encounter this then please enable WMM on your wireless AP or Wireless router the Smartphone is connected to. The location of this option will vary from wireless router to router; however as a general rule it can be found somewhere under the QoS (Quality of Service) options and as a general rule is not enabled as default.

e.g. Cisco Router.

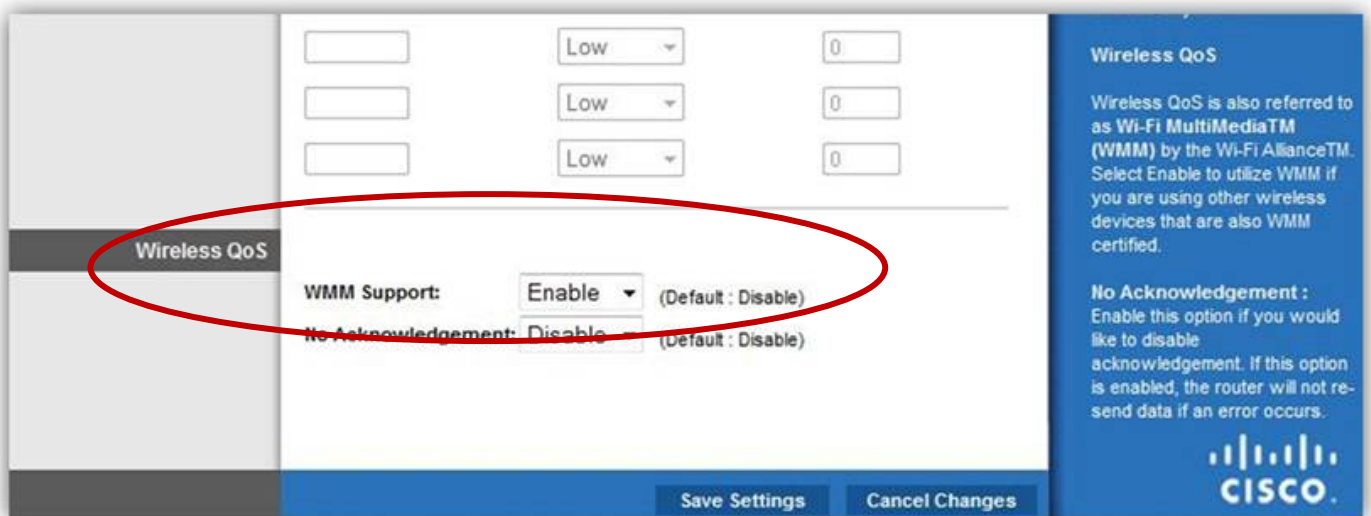

If your router does not support this feature you will need to either replace the router with one that does, or add a wireless AP onto the LAN that does support this feature and then have the Smartphone connect to it via Wifi.

iPhone pairing and setting flow (Includes iPhone & iPad)

**Download Intercom User Software App from iTunes (App Store).
Search “Ness Smartbell”**



Ness Smartbell



**Turn on Wi-Fi connection in the iOS device
Connect to eGateway via the Wi-Fi AP**



Edit the device registration information in eGateway and then press “Start Pairing”



**Start the device App on the Smartphone and complete the registration details, including Account /
Password eGateway IP address etc (to match those of the eGateway) and then press ‘Registration’**



Completed the pairing of the device.

iOS Smart Device pairing to the eGateway

1. Plug your computer into the same network as the **WAN Port** and connect using a web browser with the eGateway WAN IP address.
2. Enter in the username and password. (Default User = admin Pass=admin)
3. Click **Settings > Unit pairing**.



4. Click the **Add** button.

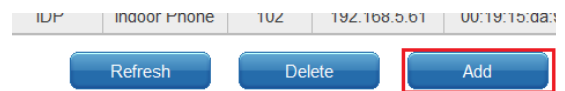

5. SELECT the new device and click **Edit**.

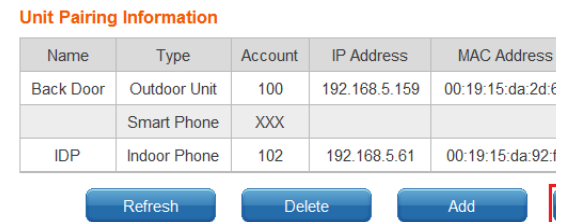

Edit Unit

Name Enter the appropriate name according to personal needs. (e.g. Fred's Phone)

Type Select **Smart Phone**

Account Please fill in the range of 100 to 109 ensuring this number is not registered

Password Enter in a password.

Unit Information

Name	Android
Type	Smart Phone
Account	101
Password	101
MAC Address	
IP Address	
Status	Initial



Press the **Save** button
Then click **Start Pairing**

6. On your iDevice (iPhone/iPad) tap on the **Settings** icon

from the home screen.

7. Scroll down the list into you find **Ness Smartbell** and tap on it.



8. Fill out the following items

Name

Enter Account (100-109) as per the pairing screen in the eGateway.

Password

Enter password as per the pairing screen in the eGateway.

Intranet Server IP

Please enter the eGateway's **WAN** IP Address.

Internet Server IP

Enter in your routers external IP address. You can get this by typing in 'What is my IP' into Google.

Server Port

You should leave this as **5060** unless you have changed it in the eGateway.

Monitor View Mode

This allows you to change the size of the image shown when a Outdoor station calls. Recommend to leave it as **1**.

Silent

OFF = Ness Smartbell will make sounds.
ON = Ness Smartbell will mute all sounds from the app.
Recommend to leave it to **OFF**.

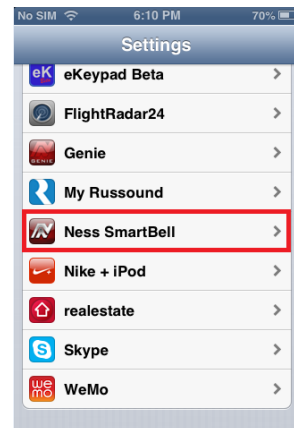

9. Once the items have been filled in press the **Home** button on the smart device



10. Find the **Ness Smartbell** app icon on the home screen and tap on it.



11. Once the app has opened and it's connected, press the **save** button in the web GUI.

Function chart

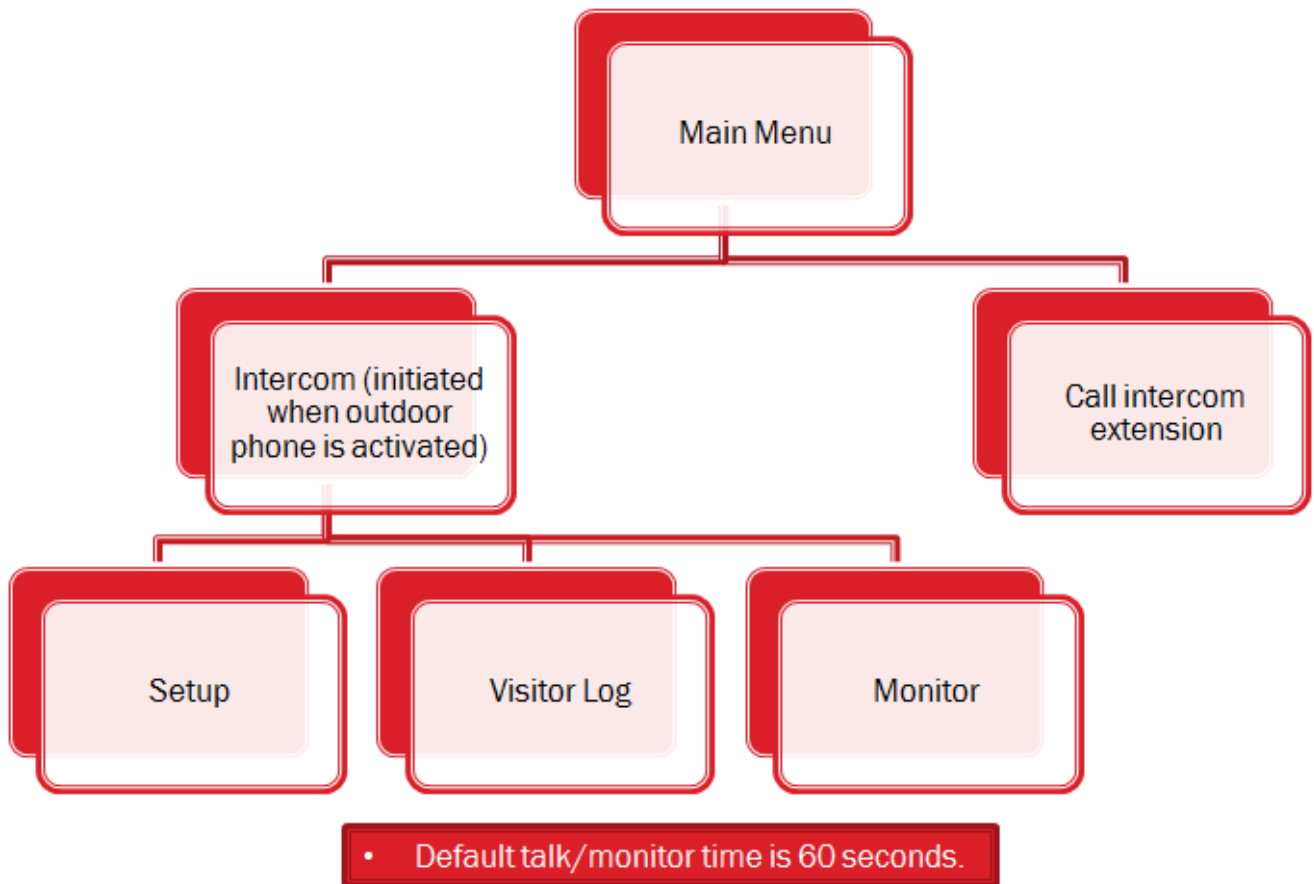

The Smartbell 10inch Touch screen is automatically activated when the Outdoor Phone / Door Station is pressed.

Once activated the following screen is displayed on your room Station or Smartphone.

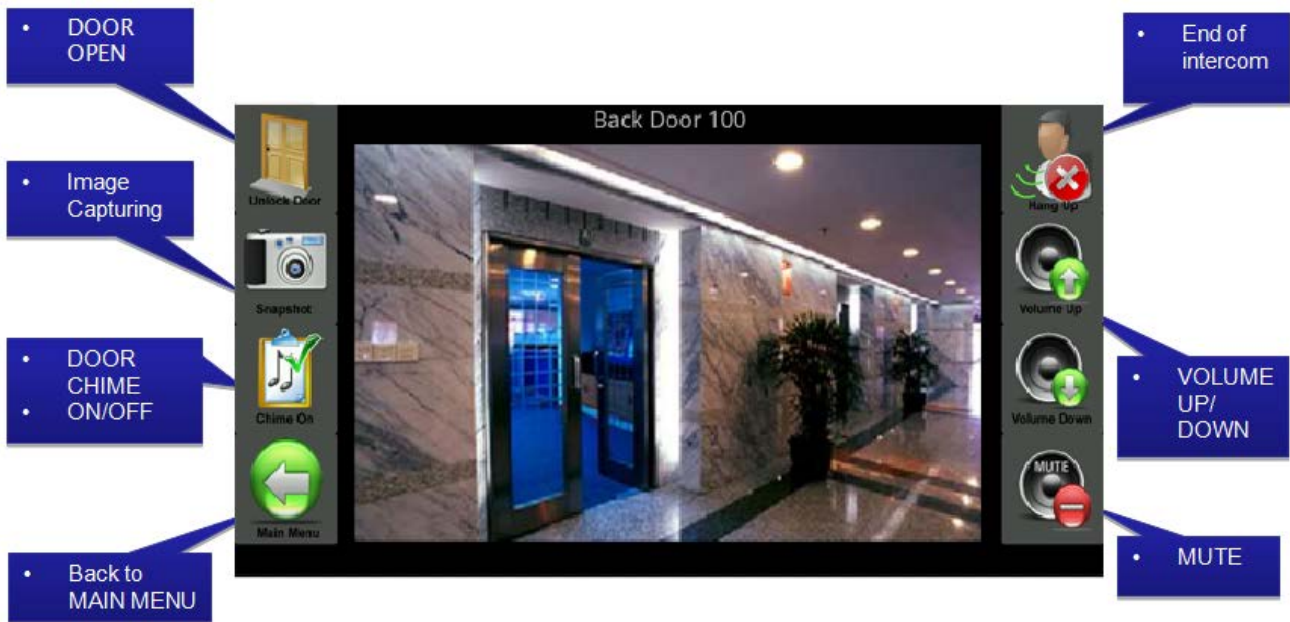

• Default talk/monitor time is 60 seconds.

Please Note: The above screen shot sample may vary depending on what device you are using. (E.g. Indoor Phone IDP, Android Smartphone or iOS Smartphone)

END: This will end the conversation and close the Active window.

Vol. +: When pressed it will turn the Volume Up if you are having trouble hearing the Visitor.

Vol. - : When pressed it will turn the Volume Down if you are having trouble hearing the Visitor.

Mute: When Mute is Off (Button is Green) visitors will be able to hear you. When ON (Button is Red) you will be muted and visitors will not be able to hear you.

Door Open: Activates the Outdoor Phone relay / Door lock, and if programmed, it will send a message to a 3rd party device, such as the Ness M1 Security & Automation controller. Before the output (or message) is activated you will be prompted to confirm you wish to activate the event.

Image Capturing: When activated it will save a snapshot image of the camera view at the Outdoor phone onto your device.

Door Chime On/Off: Will toggle the Chime function On and Off.

Main Menu: When pressed will close the Door Intercom window and returns to the main menu page.

Once this Door Intercom window is open it provides a talk time of 60 seconds. After this time the window will close. If you wish to continue the conversation you will need to activate it again.

Mobile device pairing and setting flow chart

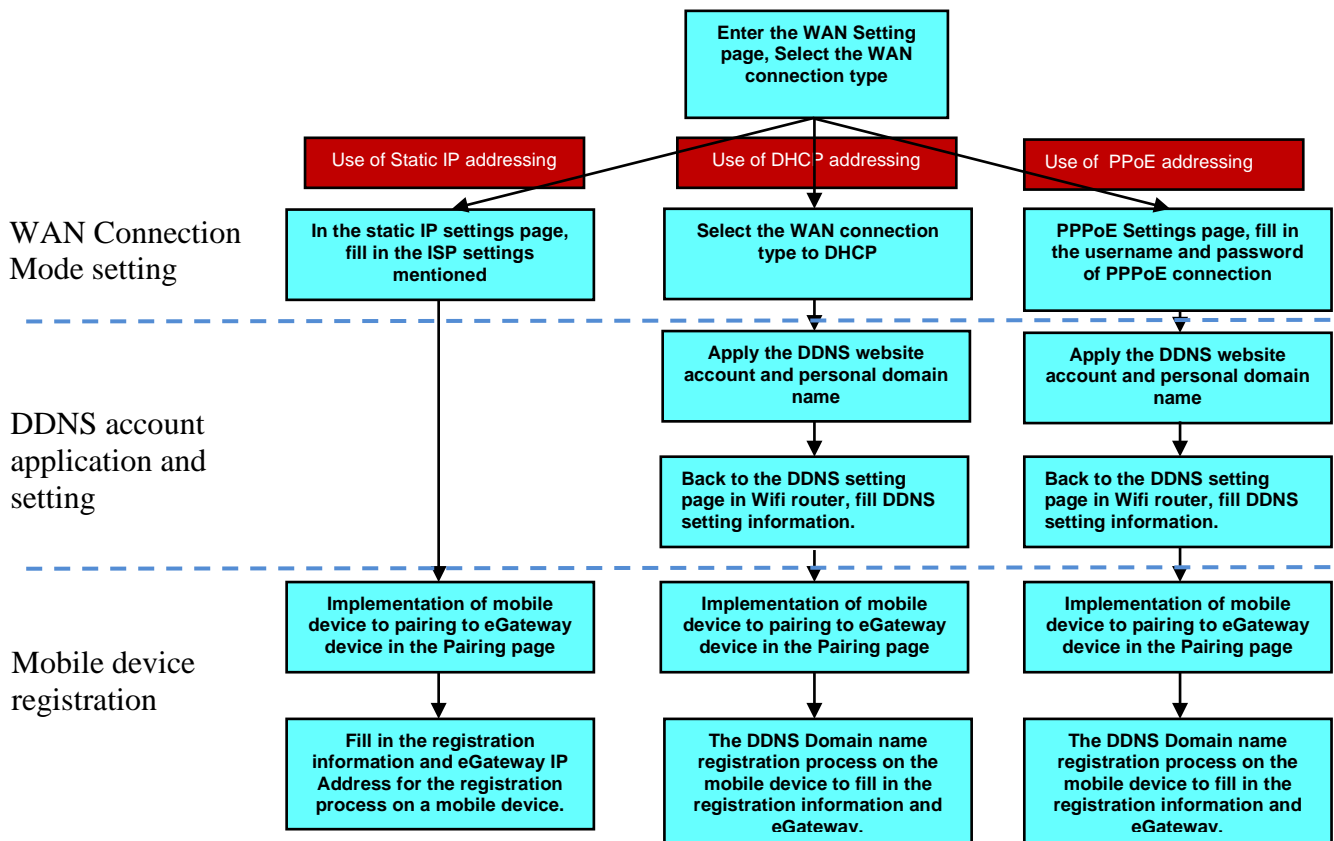

Use of STATIC IP addressing setting

The following settings show the correct settings for using a static IP address in the eGateway.

Note: Recommend you set a Static WAN IP address in the eGateway.

Wide Area Network (WAN) Settings

WAN Connection Type: 1. Select "STATIC (Fixed IP)".

Static Mode

IP Address: 2. Fill in ISP provided network setting information.

Subnet Mask:

Default Gateway:

Primary DNS Server:

Secondary DNS Server:

3. Press "Apply" button.

Use of DHCP addressing settings

The following settings show the correct settings for using DHCP in the eGateway.

Wide Area Network (WAN) Settings

WAN Connection Type: 1. Select "DHCP (Auto config)".

DHCP Mode

Hostname(optional):

2. Press "Apply" button.

DDNS account application and setting

1. Introduction to DDNS.
2. To apply for an account and personal domain in the DDNS website.
3. Set the DDNS to Wifi router.

Introduction on DDNS

- ▶ Dynamic DNS or DDNS is a term used for the updating in real time of Internet Domain Name System (DNS) name servers to keep the active DNS configuration of their hostnames, addresses and other information up to date.
- ▶ DNS (Domain Name Server) is a network device IP address feature of the server through the URL query example, when the user through a browser to connect to "www.xxx.com" the DNS on the network will convert this URL to the corresponding IP address, the browser will be able to connect to this IP address where the WWW server is.
- ▶ Normally, the DNS can only provide a static IP address query the DDNS (Dynamic Domain Name Server) function is to solve the DNS cannot query the problem of dynamic IP, it can be automatically updated each time a user changes the floating IP, and then with URL that corresponds to, so that other Internet users through the web site to check the correct IP and then to communicate.

Wi-Fi Router using the DDNS function

- ▶ When the WiFi Router WAN Connection Type is set to DHCP or PPPoE (Dynamic IP address), the WiFi Router registered to the DDNS, each WiFi router by the ISP's server to obtain new IP address, the DDNS of WiFi router will automatically updates the IP address.
- ▶ Mobile device to be registered, first DDNS ask the IP address of the WiFi Router, and then to be registered back to the eGateway via the WiFi router.

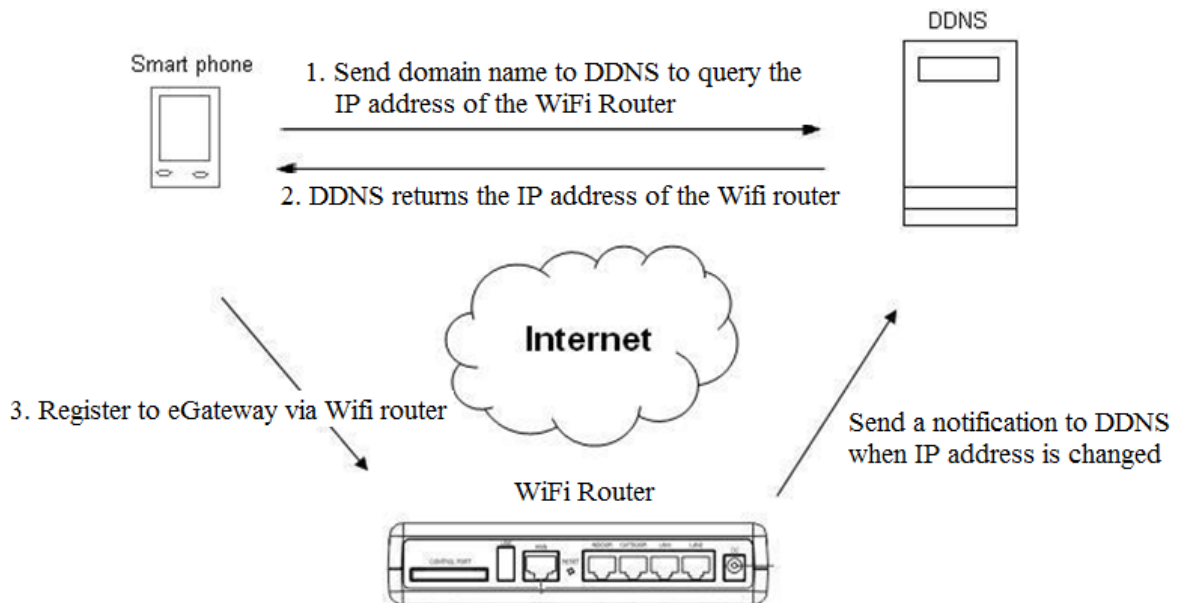

To apply for an account and personal domain in the DDNS website.

If you do not have a fixed IP address at your premises and you wish to access your Intercom externally (e.g. via 3G) you will need to connect to a DNS service. There are many service available such as 'DynDNS', 'No-IP' etc.

The following will provide details on how to setup and connect to the "No-IP" service.

1. Open browser and input www.no-ip.com.

2. Click "No-IP Free".

3. Input your email address and then click "Sign Up Now!" button.

4. Fill out relevant information.

5. Check "I agree that...".

6. no-ip.com will send a account activation mail to you after the button clicked

Check your mail box and open “Subject : No-IP.com Activation” mail.

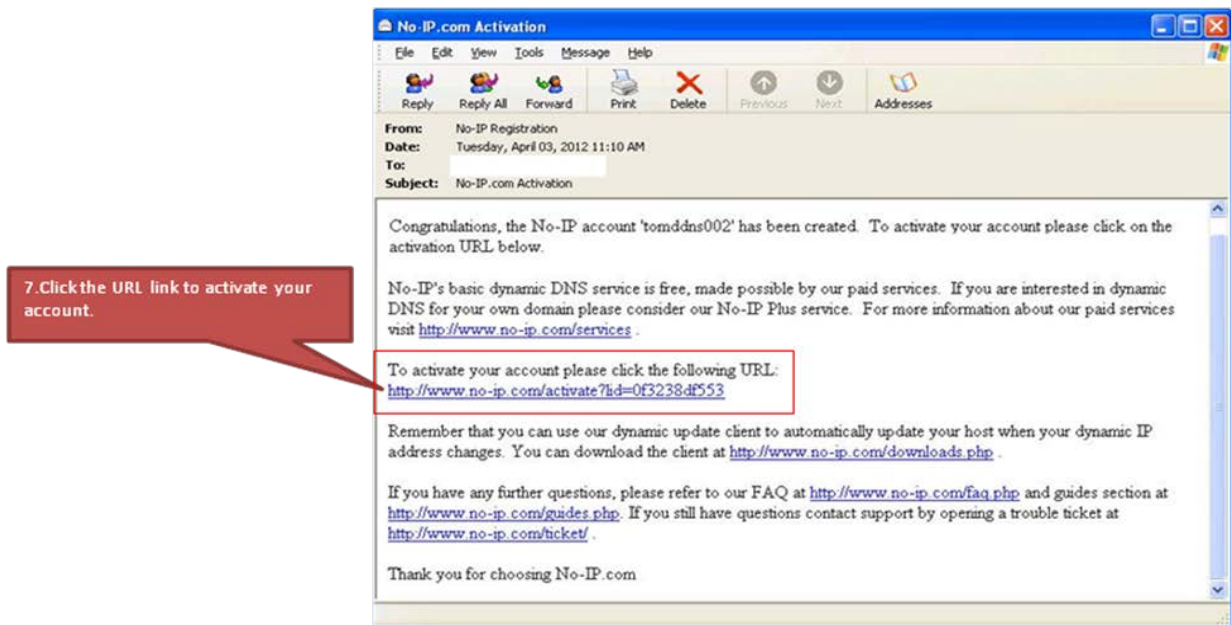

Back to no-ip.com homepage (www.no-ip.com), and then login member section.

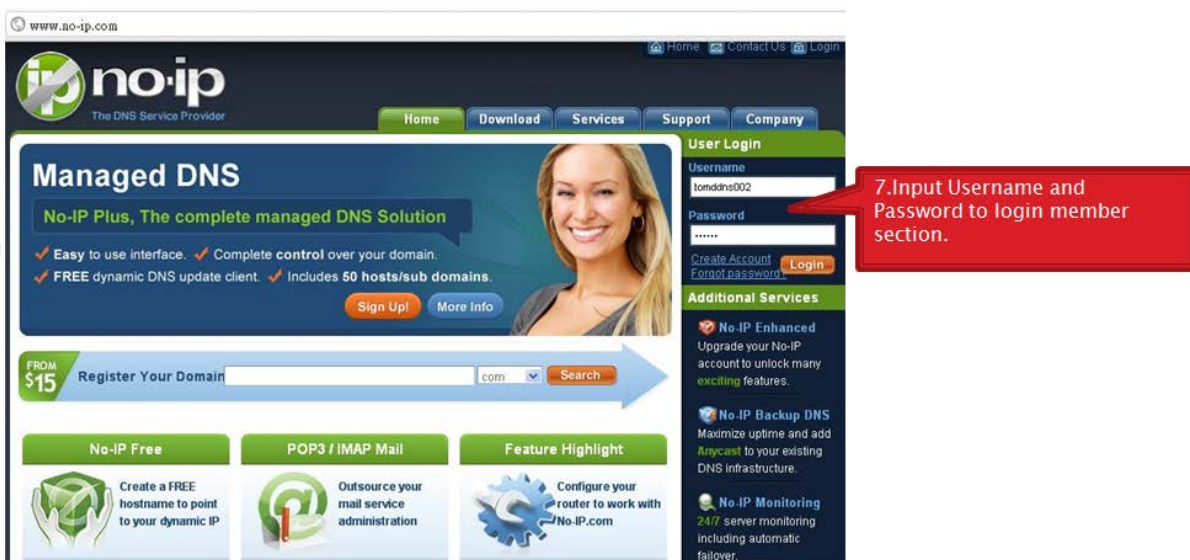

8. Select "Hosts/Redirects" -> "Add Host".

9. Fill in a name of your choosing.

10. Select a domain.

11. Select "DNS Host (A)".

12. Click "Create Host".

Finish domain creation.

Set the DDNS to WiFi router

1. Select DDNS provider.

2. Input your account, password and registered domain name.

3. Press "Apply" button.

When the WAN connection type of eGateway use DHCP

- “Extension No” => Enter account is inputted in eGateway.
- “Registration No” => Enter password is inputted in eGateway.
- “Server Address” => Key-in the DDNS of Domain name of eGateway.
- The main page will pop-out when registration is completion.

Please Enter Extension No.: 103
Please Enter Registration No.: 103103
Default Server Address: 192.168.0.10
Server Address: intercomtest0407.no-ip.org
MAC Address:
Version: SMP_0.3.1
Registration Demo



When the WAN connection type of eGW set as DHCP, the WAN IP address of eGW is dynamic IP address. It is essential to have the correct IP address through DDNS

DDNS Settings

Dynamic DNS Provider	www.no-ip.com
Account	tomddns002
Password	*****
DDNS	intercomtest0407.no-ip.org

(DDNS Settings screen of eGW)

Outdoor Unit Settings

Selecting **Settings** > **Outdoor Unit** you can change the outdoor phone station settings.

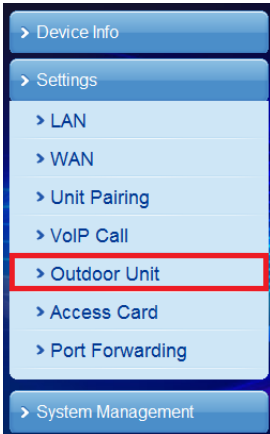

The eGateway supports 2 Outdoor units.

Outdoor Settings

When the Outdoor phone station door bell button is pressed you can control when the LED is to be turned on.

The **Start Time** and **End Time** is the time you want the LED to be turned on.

For Example:

In the example below the white LED (the one left of the camera) on the door station will be turned on between 18:00 and 06:00 (6:00PM – 6:00AM). All other times the white LED will not turn on.

The **Open Time** is how long you want the relay on the Outdoor phone to activate for when you unlock the door from the app.

In the example below the relay will activate for half a second.

The **Ring Time** is how long you want the door bell to ring for.

In the example below if someone presses the door bell button it will ring the app and the outdoor phone for 30 seconds.

Outdoor Settings

Type	Status	Start Time (hour)	Start Time (minute)	End Time (hour)	End Time (minute)	Open Time (ms)	Ring Time(s)
Front	Closed	18	0	6	0	500	30
Back	Closed	18	0	6	0	500	30

Apply

Volume Control

The **Volume Control** settings, allows you to adjust the outdoor phone volume settings.

Speaker Volume

Adjusting this will make the volume on the outdoor phone louder or softer. The lower the number the softer it will be, the higher the number the louder it will be.

Mic Volume

This will adjust the microphone sensitivity on the outdoor phone. The higher the number the more sensitivity it will be making it easier to hear the person at the door.

Volume Control

Type	Speaker Volume	MIC Volume
Front	5 ▾	8 ▾
Back	5 ▾	8 ▾

Third Party Security System Integration



Network Architecture

The Ness IP Intercom system will support high level interface to 3rd part products, such as the Ness Security and Automation controller (Ness M1), when either the Outdoor Phone Call button is pressed or the 'Unlock Door' button is activated.

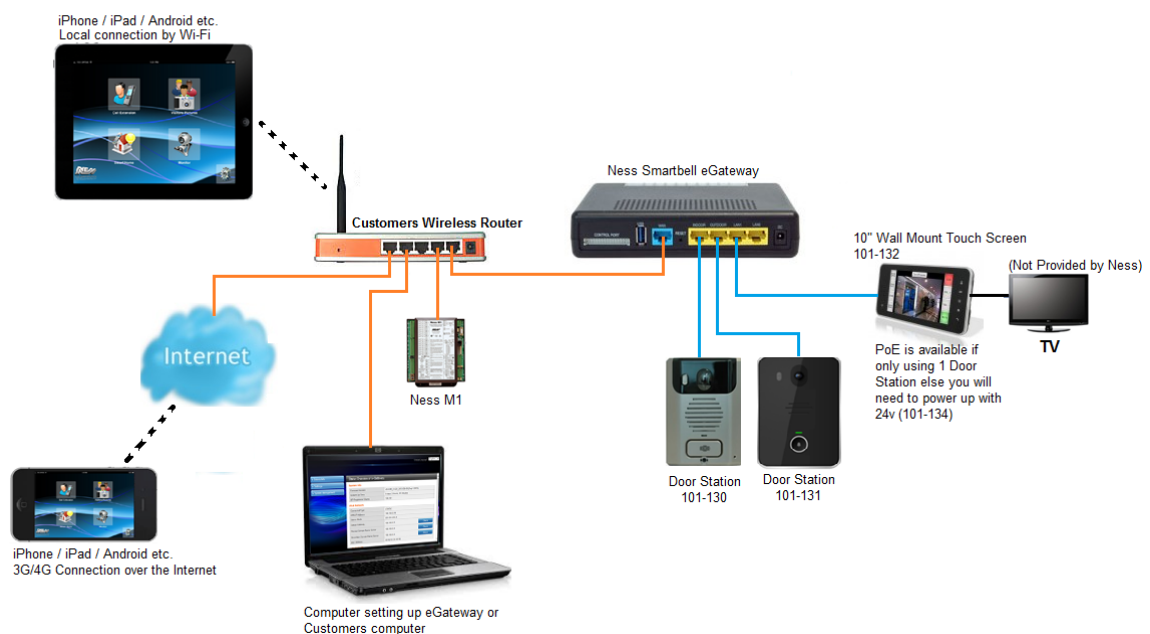

Third Party Integration Setting

To set up the third part integration follow these steps below:

1. Plug your computer into the same network as the **WAN Port** and connect using a web browser with the eGateway WAN IP address.



2. Enter in the username and password when prompted (Default User = admin Pass=admin)

3. Click **Settings > Outdoor Unit**.

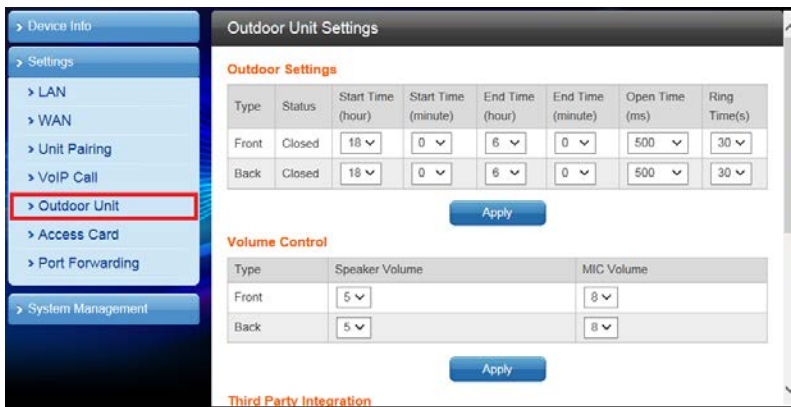

4. Scroll down the page into you find **Third Party Integration**.

Third Party Integration

Event	IP Address	Port	Command
Front Door Opening	<input type="text"/>	<input type="text"/>	<input type="text"/>
Back Door Opening	<input type="text"/>	<input type="text"/>	<input type="text"/>
Front Door Visitor Calling	<input type="text"/>	<input type="text"/>	<input type="text"/>
Back Door Visitor Calling	<input type="text"/>	<input type="text"/>	<input type="text"/>

Apply

5. There are 4 types of events we can use and send:

Front Door Opening

When you unlock the front door (ODP 1) you can send a message

Back Door Opening

When you unlock the back door (ODP 2) you can send a message

Front Door Visitor Calling

When a visitor presses the door bell button on the front door (ODP 1) you can send a message to an IP address.

Back Door Visitor Calling

When a visitor presses the door bell button on the back door (ODP 2) you can send a message to an IP address.

6. Input the IP address, port number and command for the third party system, then press the **Apply** button to save the settings.

Third Party Integration

Event	IP Address	Port	Command
Front Door Opening	<input type="text"/>	<input type="text"/>	<input type="text"/>
Back Door Opening	<input type="text"/>	<input type="text"/>	<input type="text"/>
Front Door Visitor Calling	<input type="text"/>	<input type="text"/>	<input type="text"/>
Back Door Visitor Calling	<input type="text"/>	<input type="text"/>	<input type="text"/>

The IP address for third party security system

The port for third party security system

The command will be send to third party security system when event is triggered.

IP Address

This is the IP address you want to send the ASCII message to.

Port Number

This the port number the IP above is listening on.

Command

This is the message to send to the IP address.

Don't forget to include the ^ as the carriage return if your 3rd party product requires it.

Example:

To make it activate output six for 5 seconds on a M1 with the IP 192.168.0.251 and Port 2101 when the Front Door is unlocked (front Door Opening) you would use:

(Note you need use the normal socket connection 2101 and not the SSL 2601 socket connection)

Event	IP Address	Port	Command
Front Door Opening	<input type="text" value="192.168.0.251"/>	<input type="text" value="2101"/>	<input type="text" value="0Ecn0060000500CF^"/>

Tip: You may find it easy to use the M1 Advance SDK to find the command you need to send when sending commands from the Ness Smartbell to the Ness M1. This Software can be found on the M1 Downloads page on the Ness Website.

Push Notification APNS

Selecting **System Management > Certificate Update** you can update the Smartbell Certificate files.

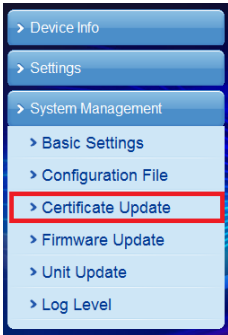

The **Name** and **Private Key Password** fields needs to stay as default.

Name – ness

Private Key Password - intercomlite

APNS Certificate Setting

Name	<input type="text" value="ness"/>
Private key password	<input type="text" value="intercomlite"/>

The **Import APNS Certificate** allows you to import the certificate file manually. This will be very rarely used.

Import APNS Certificate

Certificate file location	<input type="text"/> <input type="button" value="Browse..."/>
---------------------------	---

The **APS Client Setting** is a important field in the eGateway.

This is the location where the Ness Smartbell will automatically check to see if there are any new certificate files and will load them in.

For this feature to work you need to make sure it's set to **Enable** and that the **server URL** is set to **smartbell.ness.com.au**

The **Manual Operation** will test this and it will automatically load the new certificate file into the eGateway. If you change the **Server URL** you must click **Apply** before pressing the **manual operation** button.

APS Client Setting

Enabled	<input type="text" value="Enable"/>
Server URL	<input type="text" value="smartbell.ness.com.au"/>

Testing Push Notifications

There are 2 ways you can test if the Push Notifications work or not.

To test to see if the Push Notifications work you must first have an Apple Device paired into the eGateway. Please refer to the section on how to pair the device into the eGateway.

1. Press the Door bell button.

Pressing the door bell button will activate the push notification and it will be sent to your Apple device.

However, you will only get the Push Notification if your Apple device is paired and the app is not open on the device.

2. Manually activating it in the eGateway.

Open the **Device Overview** > **Status Overview** from the eGateway's web GUI.

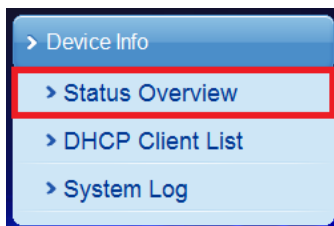

Scroll down the page into you get to the bottom of the page and you will see the following:

Push Notifications

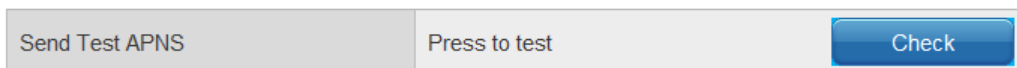

Make sure your Apple Device is paired already in the eGateway and ensure the app is closed, then press the **Check** button in the eGateway.

A few seconds later you should see a test Push Notification appear.

If no Push Notification appears then the certificate file may have expired or your DNS settings may not be valid.

Remote Access

Note:

It is up to the customer to ensure that their ISP does not block ports and that they are able to open DMZ in their router for remote access if required. Ness will not support and will not open ports for customers if they are unsure on how to do it, and customers will need to talk directly to their ISP for help and further information.

It is the customer's responsibility to ensure the system is secure at all times when using DMZ or Port forwarding any ports in their router / modem.

To use the Ness Smartbell remotely over the internet or on the mobile phone network you need to ensure you have internet access on your smart device and that you have remote access to your Ness Smartbell eGateway.

It is easier to use DMZ to the WAN's IP address of the eGateway in the router/modem when possible. If DMZ is not available then you may need to open each port individually in your router/modem.

Below is a list of ports that the Ness Smartbell uses and needs to be checked to ensure they are not blocked by the ISP or mobile phone provider.

Port	TCP/UDP
443	TCP
80	TCP
5060	UDP
5080	UDP
6060	UDP
9000 - 10000	UDP
49000	TCP
49001	TCP
49002	TCP
49004	TCP
49006	TCP
49011	UDP
49012	UDP
49013	UDP
49014	UDP

Port	TCP/UDP
49011	UDP
49012	UDP
49013	UDP
49014	UDP
49015	UDP
49016	UDP
49017	UDP
49018	UDP
49019	UDP
49020	UDP
49021- 49030	UDP
49031- 49070	UDP
49071- 49090	TCP
49011	UDP
49012	UDP

Troubleshooting (FAQs)

Q. It works locally on the Wi-Fi but does not work on 3G / 4G?

- A.**
- Make sure you have opened the ports in the router / modem.
 - Make sure the ISP is not blocking any ports
 - Make sure the Mobile phone provider is not blocking ports (such as 5060)
 - Make sure your mobile phone has mobile data enabled
 - Make sure you are using the correct external (Public) IP / hostname
 - Make sure the external (public) IP is saved in the correct location in the settings

Q. No video comes up when talking to the Outdoor station, how can I fix this?

- A.**
- Try re-flashing the outdoor station firmware again.
(Remember to do the voice and video firmware.)
 - Contact technical support for a troubleshooting report form as we may need some more information from you.

Q. No sound is working on my Android Device, what can I do to fix it?

- A.** Make sure in your router, modem or even Wireless access point that WMM is enabled.

Q. It works fine on my smart device when using a Telstra Sim card but when I switch the sim card in the same device to an Optus Sim card it stops working while on 3G / 4G?

- A.** We believe that Optus are starting to block port 5060 which the Ness Smartbell requires. You may need to change the VoIP Call port to something else and need to ensure you have also changed this same port in the app. In the eGateway open the VoIP call page by going here **Settings > VoIP Call** and change the port to something like 5070 and then make sure you change it in the app as well.

Q. I can't get it to work locally on the local Wi-Fi, what is wrong?

- A.** Make sure that in your router / modem / Wireless access point that you have all options related to SIP ALG disabled.
If you still have issues then please ensure you have followed the quick guide on page 27 of his manual, and if you still have issues please contact customer service at customerservice@ness.com.au



Head Office:

4/167 Prospect Hwy,
Seven Hills NSW, Australia
Phone +61 2 8825 9222
email : ness@ness.com.au

Sydney Office - (02) 8825 9222
Melbourne Office -(03) 9875 6400
Brisbane Office - (07) 3399 4910
Perth Office -(08) 9328 2511
Adelaide Office - (08) 8277 7255

Support

Email

customerservice@ness.com.au

Phone

1300 551 991 (Within Australia)
+61 2 8825 9222 (Outside Australia)

Online

www.youtube.com/nesscorporation